

MEDICON eG · GERMANY · 47° 57' 31.4" N · 8° 46' 58.6" E



# neuro CRANIALIS

Instrumente für die kraniale Neurochirurgie  
Instruments for Cranial Neurosurgery  
Instrumentos para la neurocirugía craneal  
Instruments pour la neurochirurgie crânienne  
Strumenti per la neurochirurgia cranica

---

**medicon**<sup>®</sup>

---



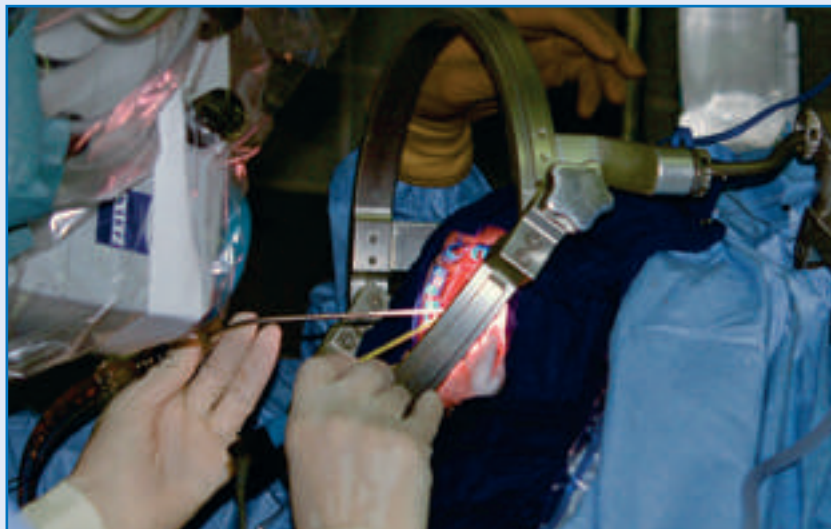

# neuro CRANIALIS

Instrumente für die kraniale Neurochirurgie  
Instruments for Cranial Neurosurgery  
Instrumentos para la neurocirugía craneal  
Instruments pour la neurochirurgie crânienne  
Strumenti per la neurochirurgia cranica

Die Entwicklung, Herstellung und der Vertrieb chirurgischer Instrumente und Implantate haben bei uns eine jahrzehntelange Tradition. In unseren 11 Mitgliedsbetrieben werden über 35.000 verschiedene Artikel für die Humanmedizin gefertigt.

Wir haben es uns zur Aufgabe gemacht, Chirurgen und OP-Personal der Neurochirurgie mit innovativen Implantaten und Instrumenten zu versorgen, welche die Fortschritte der operativen Behandlung unterstützen.

Mit Verantwortung und Engagement bündeln wir unsere Aktivitäten in drei Kernkompetenzen.

Our company has decades of experience in developing, manufacturing and selling surgical instruments and implants. Our 11 member companies produce over 35,000 different items for human medicine.

We have made it our goal to supply surgeons and surgical personnel in Neurosurgery with innovative implants and instruments, which support the progress in surgical treatment.

With responsibility and commitment, we focus our activities on three core competences.

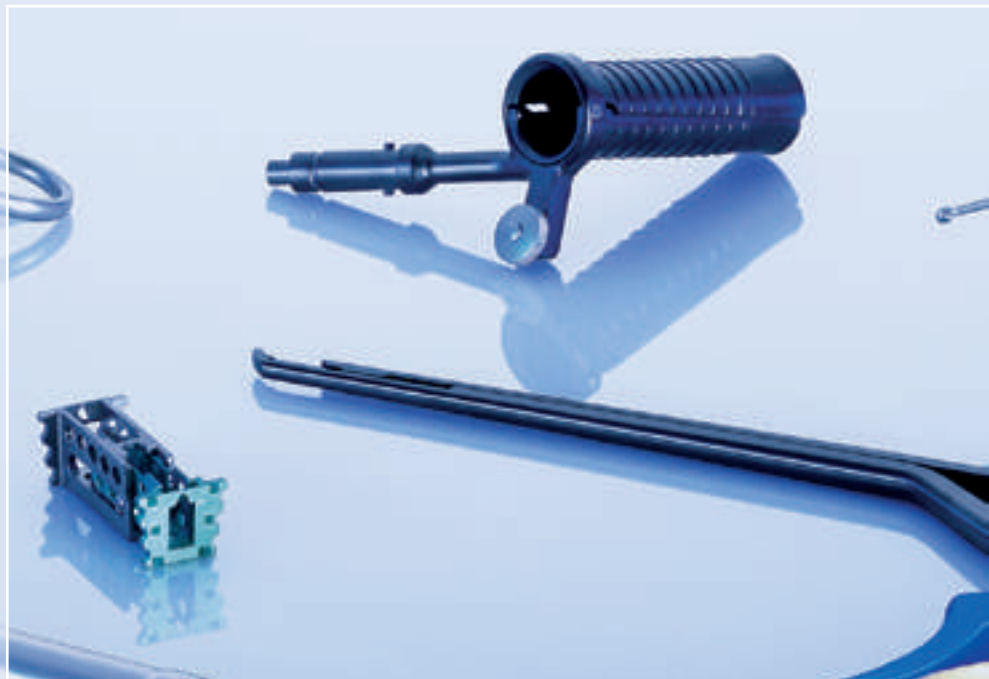

El desarrollo, la fabricación y la distribución de implantes e instrumentos quirúrgicos representa para nosotros décadas de tradición. En los talleres de nuestros 11 socios se fabrican más de 35.000 artículos diferentes para la medicina humana.

Nos hemos propuesto la tarea de abastecer a cirujanos y a personal de quirófano de la neurocirugía con innovadores implantes e instrumentos que respaldan el progreso del tratamiento quirúrgico.

Con responsabilidad y compromiso, centramos nuestra actividad en tres competencias básicas.

Le développement, la fabrication et la vente d'instruments chirurgicaux et d'implants ont une tradition longue depuis plusieurs décennies chez Medicon.

Nos 11 entreprises membres produisent plus de 35.000 articles différents dans le secteur de la médecine.

Nous nous sommes fixés pour objectif de fournir aux chirurgiens et au personnel opératoire actifs dans le secteur de la neurochirurgie des implants et instruments novateurs suivant les progrès du traitement opératoire.

Avec conscience et engagement, nous regroupons nos activités dans trois compétences majeures.

Lo sviluppo, la produzione e la distribuzione di strumenti chirurgici e impianti hanno da noi una tradizione pluridecennale.

Nelle nostre 11 aziende associate, vengono fabbricati oltre 35.000 diversi articoli per la medicina umana.

Il compito che ci siamo proposti è quello di fornire ai chirurghi e al personale di sala operatoria di neurochirurgia impianti e strumenti innovativi che supportano i progressi del trattamento chirurgico.

Con responsabilità e impegno riuniamo le nostre attività in tre competenze di base.



## III CMF

Das Kompetenzfeld **CMF** kombiniert unsere modular aufgebauten Systeme für die Distraction und Osteosynthese in der kranio-maxillo-fazialen Chirurgie mit anwendungs-optimierten Lösungen und intuitiver Bedienbarkeit zu einem zukunfts-orientierten Konzept.

The competence field **CMF** combines our modular systems for distraction and osteosynthesis in Cranio-Maxillofacial surgery with application-optimised solutions and intuitive operation to produce a forward-looking concept.

## II SURGICAL

Das Kompetenzfeld **SURGICAL** vernetzt unsere mehr als siebenjährige Erfahrung als Medizintechnik-Unternehmen mit weit über 35.000 Produkten, die nahezu alle Indikationen der einzelnen chirurgischen Fachbereiche abdecken.

The competence field **SURGICAL** links our more than seventy years of experience as a medical technology company with over 35,000 products covering nearly all indications of the individual surgical specialty fields.

## III NEURO+SPINE

Das Kompetenzfeld **NEURO+SPINE** konzentriert sich auf unser Produkt-Portfolio von qualitativ hochwertigen Instrumenten und innovativen Implantaten für die Neurochirurgie mit dem Fokus der produktbezogenen Spezialisierung als Grundlage einer transparenten Vertriebsstrategie.

The competence field **NEURO+SPINE** focuses on our product portfolio of high-quality instruments and innovative implants for Neurosurgery with the main emphasis on product-related specialisation as a basis for a transparent sales strategy.

El área de especialización **CMF** combina nuestro sistema modular para la distensión y osteosíntesis en la cirugía cráneo-maxilofacial con soluciones orientadas a la aplicación y un manejo intuitivo para desarrollar un concepto enfocado hacia el futuro.

Le domaine de compétence **CMF** associe nos systèmes modulaires utilisés pour la distraction et ostéosynthèse en chirurgie crânio-maxillo-faciale à des solutions d'application optimisées et à une manipulation intuitive. Le résultat: Un concept d'avenir.

L'area di competenza **CMF** associa i nostri sistemi componibili per la distrazione e la osteosintesi nella chirurgia cranio-maxillo-facciale a soluzioni ottimizzate nell'applicazione e manipolazione intuitiva, per un concetto orientato al futuro.

El área de especialización **SURGICAL** fusiona nuestros más de 70 años de experiencia como empresa de tecnología médica con más de 35.000 productos que cubren casi todas las indicaciones de cada una de las disciplinas quirúrgicas.

Le domaine de compétence **SURGICAL** allie notre expérience de plus de 70 années dans le secteur des techniques médicales à plus de 35.000 produits, couvrant la quasi-totalité des indications de la chirurgie actuelle.

L'area di competenza **SURGICAL** collega la nostra ultrasettantennale esperienza aziendale nel campo della tecnica medica con oltre 35.000 prodotti che soddisfano quasi tutte le indicazioni delle singole aree di specializzazione chirurgiche.

El área de especialización **NEURO+SPINE** se centra en nuestra cartera de productos de instrumentos de alta calidad e implantes innovadores para la neurocirugía considerando la especialización relacionada con los productos como base de una estrategia de ventas transparente.

Le domaine de compétence **NEURO+SPINE** se concentre sur notre gamme d'instruments de grande qualité et d'implants novateurs pour la neurochirurgie, avec une spécialisation sur les produits comme base d'une stratégie de vente transparente.

L'area di competenza **NEURO+SPINE** si concentra sul nostro portfolio di strumenti di alta qualità e impianti innovativi per la neurochirurgia, e si propone come focus la specializzazione del prodotto come base di una trasparente strategia di distribuzione.

Der Ihnen vorliegende Katalog "Instrumente für die kraniale Neurochirurgie" bleibt unser Eigentum, auch wenn eine Leih- oder Schutzgebühr bezahlt wurde. Er darf nur zum Einkauf und Vertrieb der darin beschriebenen MEDICON-Produkte durch den dazu autorisierten Fachhandel und für die Bedarfsbeschaffung durch den jeweiligen Anwender verwendet werden. Seine Verwendung gegen unsere Interessen berechtigt uns zur sofortigen Rückforderung und möglichen weitergehenden Maßnahmen. Ohne unsere ausdrückliche, schriftliche Genehmigung darf dieser Katalog weder im Gesamten noch auszugsweise nachgedruckt oder kopiert werden.

This present "Instruments for Cranial Neurosurgery" catalogue remains exclusively our property even if a lending fee or charge has been paid for it. It shall only be used by specialized dealers to buy and sell MEDICON products or by individual users to meet their own requirements. In case of misuse we are entitled to recall the catalogue immediately and to take further steps if necessary. It is not allowed to reprint or copy this catalogue in whole or in parts without our written permission.

El presente catálogo "Instrumentos para la neurocirugía craneal" sigue siendo nuestra propiedad aunque se ha pagado ciertos derechos de préstamo. Debe servir a los revendedores autorizados del ramo exclusivamente para la compra y la distribución de los productos MEDICON que describe, y a los especialistas y usuarios particulares para escoger los instrumentos necesarios para su abastecimiento. Su empleo abusivo en perjuicio de nuestros intereses, nos da derecho a exigir su devolución inmediata y a tomar todas las medidas ulteriores que juzguemos necesarias. Sin nuestro permiso expreso por escrito es prohibido reproducir o copiar este catálogo, tanto en su totalidad como en extractos.

Le présent catalogue "Instruments pour la neurochirurgie crânienne" demeure notre propriété, même après acquittement d'une taxe autorisée ou taxe de prêt. Il ne peut être utilisé que pour l'achat ou la vente des produits MEDICON qui y sont décrits, par des spécialistes y étant autorisés et par l'utilisateur pour l'approvisionnement de ses besoins. Son utilisation contre nos intérêts nous autorise à une demande en restitution immédiate et à la prise éventuelle de mesures disciplinaires. Sans autorisation formelle écrite, ce catalogue ne peut être ni réimprimé, ni copié, que ce soit complètement ou partiellement.

Il presente catalogo "Strumenti per la neurochirurgia cranica" rimane di nostra proprietà anche se è stato pagato un diritto di noleggio o di proprietà riservata. Esso può essere adoperato soltanto per l'acquisto e la vendita dei prodotti MEDICON ivi descritti attraverso il commercio specializzato e autorizzato o per l'approvvigionamento tramite chi, di volta in volta, li impiega. L'uso del catalogo contro i nostri interessi ci autorizza al suo immediato ritiro e possibili ulteriori provvedimenti. Senza la nostra esplicita autorizzazione scritta questo catalogo non può essere ristampato o copiato nè integralmente nè parzialmente.

Modelländerungen vorbehalten  
Patterns are subject to change  
Salvo modificaciones  
Tous droits réservés des changements de modèle  
Ci riserviamo la facoltà di cambiamenti nei modelli

Für Druckfehler übernehmen wir keinerlei Haftung  
We are not liable for misprints  
Declinamos toda responsabilidad por los errores de impresión que pueda contener este documento  
Nous déclinons toute responsabilité en cas d'erreurs d'impression  
Non ci assumiamo nessuna responsabilità per eventuali errori di stampa

Gedruckt in Deutschland  
Printed in Germany  
Impreso en Alemania  
Imprimé en Allemagne  
Stampato in Germania  
Trykket i Tyskland

© Copyright 10/2013, MEDICON eG, Tuttlingen, Germany



**Standardinstrumente  
Basic Instruments  
Instrumentos básicos  
Instruments de base  
Strumenti di base**

**A**

**Instrumente für die kraniale Neurochirurgie  
Instruments for Cranial Neurosurgery  
Instrumentos para la neurocirugía craneal  
Instruments pour la neurochirurgie crânienne  
Strumenti per la neurochirurgia cranica**

**B**

**Siebvorschläge  
Set Suggestions  
Proposiciones de juegos  
Propositions pour boîtes  
Proposte di set**

**C**

**Alphabetischer und numerischer Index  
Alphabetical and Numerical Index  
Indice alfabético y numérico  
Index alphabétique et numérique  
Indice alfabetico e numerico**

**D**

# A

## Standardinstrumente Basic Instruments Instrumentos básicos Instruments de base Strumenti di base

<b>A01</b>	Skalpellsklingen und Skalpellgriffe Scalpel blades and scalpel handles Hojas de bisturí y mangos de bisturí Lames de bistouris et manches pour bistouris Lame per bisturi e manici per bisturi	3
<b>A02</b>	Scheren Scissors Tijeras Ciseaux Forbici	7
<b>A03</b>	Pinzetten Forceps Pinzas Pincas Pinze	31
<b>A04</b>	Bipolare Pinzetten Bipolar forceps Pinzas bipolares Pincas bipolaires Pinze bipolari	57
<b>A05</b>	Nadelhalter Needle holders Porta-agujas Porte-aiguilles Portaghi	65
<b>A06</b>	Saug- und Spülinstrumente Suction and irrigating instruments Instrumentos de aspiración y de lavado Instruments à aspiration et à irrigation Strumenti per aspirazione e lavaggio	79
<b>A07</b>	Klemmen Clamps Pinzas Clamps Pinze	85
<b>A08</b>	Gefäßclips Vessel clips Clips vasculares Clips vasculaires Clip vascolari	89
<b>A09</b>	Wundhaken und Wundspreizer Retractors and self-retaining retractors Separadores y separadores autoestáticos Ecarteurs et écarteurs autostatiques Divaricatori e divaricatori autostatici	99
<b>A10</b>	Elevatoren und Raspatorien Elevators and raspatories Elevadores y legbras Elévateurs et rugines Elevatori e periostotomi	105
<b>A11</b>	Hohlmeißel- und Knochensplitterzangen Bone rongeurs forceps and bone cutting forceps Pinzas-gubias y pinzas cortantes para huesos Pincas-gouges et pincas coupantes à os Pinze-sgorbie e pinze ossivore	119

# B

## **Instrumente für die kraniale Neurochirurgie Instruments for Cranial Neurosurgery Instrumentos para la neurocirugía craneal Instruments pour la neurochirurgie crânienne Strumenti per la neurochirurgia cranica**

<b>B01</b>	Kopfhalterungssystem Head rest system Sistema de fijación craneal Système de maintien crânien Sistema di fissazione cranica	131
<b>B02</b>	Kopfhautklammern Scalp clips Clips hemostáticos para cuero cabelludo Clips hémostatiques pour cuir chevelu Clip emostatiche per cuoio capelluto	139
<b>B03</b>	Instrumente für die Trepanation und Kraniotomie Instruments for the trepanation and craniotomy Instrumentos para la trepanación y craneotomía Instruments pour la trépanation et craniotomie Strumenti per la trapanazione e craniotomia	143
<b>B04</b>	Stanzen Rongeurs Pinzas saca-bocadas Pincas emporte-pièce Laminotomi	153
<b>B05</b>	Haken und Dissektoren Hooks and dissectors Ganchos y disectores Crochets et dissecteurs Uncini e dissettori	165
<b>B06</b>	Diamantmesser und Mikro-Instrumente Diamond knives and micro instruments Cuchillos de diamante y micro instrumentos Couteau de diamant et micro-instruments Bisturi diamantati e strumenti micro	185
<b>B07</b>	Hirnspatel und Hirnspatelhalter Brain spatulas and brain spatula retractors Espátulas cerebrales y separadores para espátulas cerebrales Spatules cérébrales et ecarteurs pour des spatules cérébrales Spatole cerebrali e divaricatori cerebrali	199
<b>B08</b>	Zerebrovaskuläre Clips Cerebrovascular clips Clips cerebrovascular Clips vasculaires cérébraux Clip cerebrovascolari	207
<b>B09</b>	Neuro-Fixationssystem Neuro-fixation system Sistema para neuro-fijación Système de neuro-fixation Sistema di neuro-fissaggio	233
<b>B10</b>	Instrumente für die Hypophysektomie Instruments for hypophysectomy Instrumentos para la hipofisectomía Instruments pour l'hypophysectomie Strumenti per ipofisectomia	251
<b>B11</b>	Druckluftmotorensystem Pneumatic high speed system Sistema de motor neumático Système de moteur pneumatique Sistema motore pneumatico	265

# C

## Siebvorschläge Set Suggestions Proposiciones de juegos Propositions pour boîtes Proposte di set

<b>C01</b>	Siebvorschlag für die Schädelöffnung Set Suggestion for craniotomy Proposición de juego para la apertura del cráneo Proposition à boîte pour l'ouverture du crâne Proposta di set per l'apertura del cranio	279
<b>C02</b>	Siebvorschlag für Eingriffe an der hinteren Schädelgrube Set suggestion for procedures of the posterior cranial fossa Proposición de juego para los procedimientos en la fosa posterior del cráneo Proposition pour boîte pour les procédures sur fosse postérieure du crâne Proposta di set per le procedure sulla fossa cranica posteriore	281
<b>C03</b>	Siebvorschlag für Eingriffe am Schädel Set suggestion for procedures of the skull Proposición de juego para los procedimientos en el cráneo Proposition à boîte pour les procédures sur le crâne Proposta di set per le procedure sul cranio	282
<b>C04</b>	Siebvorschlag für die kraniale Mikrochirurgie Set suggestion for cranial microsurgery Proposición de juego para microcirugía craneal Proposition à boîte de microchirurgie crânienne Proposta di set per la microchirurgia cranica	285
<b>C05</b>	Siebvorschlag für Hydrocephalus Shunt Set suggestion for hydrocephalus shunt Proposición de juego de Shunt para hidrocefalia Proposition à boîte pour Shunt hydrocéphalie Proposta di set per l'idrocefalo Shunt	286
<b>C06</b>	Siebvorschlag für Handinstrumente der peripheren Nerven Set suggestion for hand instruments of the peripheral nerves Proposición de juego para instrumentos de mano de los nervios periféricos Proposition à boîte pour instruments à main des nerfs périphériques Proposta di set per strumenti della mano dei nervi periferici	288
<b>C07</b>	Siebvorschlag für die transspenoidale Hypophysektomie Set suggestion for transspenoidal hypophysectomy Proposición de juego para la hipofisectomía transesfenoidal Proposition à boîte pour l'hypophysectomie transsphénoïdale Proposta di set per l'ipofisectomia transfenoidale	290

# D

**Alphabetischer und numerischer Index**  
**Alphabetical and Numerical Index**  
**Índice alfabético y numérico**  
**Index alphabétique et numérique**  
**Índice alfabético e numerico**

<b>D01</b>	Alphabetischer Index	<b>DEUTSCH</b>	295
<b>D02</b>	Alphabetical index	<b>ENGLISH</b>	301
<b>D03</b>	Índice alfabético	<b>ESPAÑOL</b>	307
<b>D04</b>	Index alphabétique	<b>FRANÇAIS</b>	313
<b>D05</b>	Índice alfabético	<b>ITALIANO</b>	319
<b>D06</b>	Numerischer Index Numerical index Índice numérico Index numérique Índice numerico		326

**Hinweise**  
**Indications**  
**Indicaciones**  
**Indications**  
**Indicazioni**

Unsere Instrumenten-Abbildungen haben eine Größe von 50 %. Andere Darstellungsgrößen werden im Maßstab (zum Beispiel 1:1) angegeben. Die dazugehörigen Detailbilder sind in Originalgröße (100 %) abgebildet. Die angegebenen Bemaßungen unterliegen herstellungsbedingt einer Fertigungstoleranz.

In general the instrument illustrations are scaled to be 50 % of actual size. If other scales are used they are indicated (for example 1:1). The corresponding detailed tip illustrations are shown in actual size (100 %). The stated measurements may have a slight variation in permissible tolerances due to minor variations in manufacturing conditions.

Las ilustraciones de los instrumentos tienen un tamaño de 50 %. Otros tamaños de las ilustraciones serán indicados con la indicación en una escala (por ejemplo 1:1). Los imagenes detallados pertinentes son en su tamaño original (100 %). Las dimensiones indicadas son sujeto de tolerancias.

Nos illustrations d'instruments sont à 50 % de la taille réelle. D'autres dimensions de représentation sont données avec indication d'échelle (par exemple 1:1). Les images de détail sont projetées en taille réelle (100 %). Toutes les dimensions données ont une tolérance de fabrication.

Le illustrazioni dei nostri strumenti hanno una dimensione del 50 %. Altre dimensioni di raffigurazione sono segnate con una scala (per esempio 1:1). Le relative illustrazioni dettagliate sono illustrate in dimensioni originali (100 %). Le dimensioni indicate sono soggette a una tolleranza di fabbricazione.

Beispiel  
 Example  
 Ejemplo  
 Exemple  
 Esempio

Vorderansicht (Schere gerade)  
 Front view (straight scissors)  
 Vista frontal (tijera recta)  
 Vue de face (ciseaux droits)  
 Vista frontale (forbice retta)

Seitenansicht (Schere gebogen)  
 Lateral view (curved scissors)  
 Vista lateral (tijera curva)  
 Vue laterale (ciseaux courbes)  
 Vista laterale (forbice curva)

50 % = 7 cm

**Mayo**

Darstellungsgröße  
 Image sizes  
 Tamaño de representación  
 Dimension de représentation  
 Dimensione di raffigurazione

1:1

Instrumentengröße  
 Instrument size  
 Tamaño del instrumento  
 Taille des instruments  
 Dimensione degli strumenti

14 cm – 5½"	14 cm – 5½"	
<b>03.50.14</b>	<b>03.51.14</b>	<b>standard</b>
<b>203.50.14</b>	<b>203.51.14</b>	<b>supercut</b>
<b>213.50.14</b>	<b>213.51.14</b>	<b>blackline</b>
<b>03.50.64</b>	<b>03.51.64</b>	<b>"HM"</b>
<b>203.50.64</b>	<b>202.51.64</b>	<b>supercut plus</b>
<b>223.50.64</b>	<b>222.51.64</b>	<b>magiccut</b>

Artikelnummer  
 Item number  
 Número de artículo  
 Référence  
 Codice



Standardinstrumente  
Basic Instruments  
Instrumentos básicos  
Instruments de base  
Strumenti di base

A

neuro  
**CRANIALIS**

**Standardinstrumente**  
**Basic Instruments**  
**Instrumentos básicos**  
**Instruments de base**  
**Strumenti di base**

<b>A01</b>	Skalpellklingen und Skalpellgriffe Scalpel blades and scalpel handles Hojas de bisturí y mangos de bisturí Lames de bistouris et manches pour bistouris Lame per bisturí e manici per bisturí	3
<b>A02</b>	Scheren Scissors Tijeras Ciseaux Forbici	7
<b>A03</b>	Pinzetten Forceps Pinzas Pincés Pinze	31
<b>A04</b>	Bipolare Pinzetten Bipolar forceps Pinzas bipolares Pincés bipolaires Pinze bipolari	57
<b>A05</b>	Nadelhalter Needle holders Porta-agujas Porte-aiguilles Portaghi	65
<b>A06</b>	Saug- und Spülinstrumente Suction and irrigating instruments Instrumentos de aspiración y de lavado Instruments à aspiration et à irrigation Strumenti per aspirazione e lavaggio	79
<b>A07</b>	Klemmen Clamps Pinzas Clamps Pinze	85
<b>A08</b>	Gefäßclips Vessel clips Clips vasculares Clips vasculaires Clip vascolari	89
<b>A09</b>	Wundhaken und Wundspreizer Retractors and self-retaining retractors Separadores y separadores autoestáticos Écarteurs et écarteurs autostatiques Divaricatori e divaricatori autostatici	99
<b>A10</b>	Elevatoren und Raspatorien Elevators and raspatories Elevadores y legras Élévateurs et rugines Elevatori e periostotomi	105
<b>A11</b>	Hohlmeißel- und Knochensplitterzangen Bone rongeurs and bone cutting forceps Pinzas-gubias y pinzas cortantes para huesos Pincés-gouges et pincés coupantes à os Pinze sgorbie e pinze ossivore	119



**Skalpellsklingen und Skalpellsgriffe  
Scalpel Blades and Scalpel Handles  
Hojas de bisturí y mangos de bisturí  
Lames de bistouris et manches pour bistouris  
Lame per bisturi e manici per bisturi**

**A01**



Verpackung für Skalpellsklingen  
Packing for scalpel blades  
Paquete para hojas de bisturí  
Emballage pour lames de bistouris  
Confezione per lame per bisturi



**450.00.03**



Unser komplettes Skalpells-Programm finden Sie in unserem Hauptkatalog.  
For our complete scalpel line, see our main catalogue.  
El programa completo de bisturís se encuentra en nuestro catálogo general.  
Vous trouverez notre gamme complète de bistouris dans notre catalogue général.  
Troverete il nostro programma completo di bisturi nel nostro catalogo generale.



**Skalpellklingen und Skalpellgriffe**  
**Scalpel Blades and Scalpel Handles**  
**Hojas de bisturí y mangos de bisturí**  
**Lames de bistouris et manches pour bistouris**  
**Lame per bisturi e manici per bisturi**

A01



1:1

 **STERILE**



Fig. 10 **01.22.10** P<sub>100</sub>



Fig. 11 **01.22.11** P<sub>100</sub>



Fig. 12 **01.22.12** P<sub>100</sub>



Fig. 12d **01.22.32** P<sub>100</sub>



Fig. 15 **01.22.15** P<sub>100</sub>



Fig. 15c **01.22.35** P<sub>100</sub>



12,5 cm – 5" **01.27.03** no. 3



15,5 cm – 6 1/8" **01.27.40**



16,5 cm – 6 1/2" **01.27.07** no. 7

 Einmalprodukt  
 Single use product  
 Prodotto para un solo uso  
 Produit à usage unique  
 Prodotto monouso

 Verpackungseinheit "X" Stück  
 Packing unit "X" pieces  
 Paquete de "X" unidades  
 Emballage de "X" pièces  
 Confezione da "X" pezzi

**Skalpellklingen und Skalpellgriffe**  
**Scalpel Blades and Scalpel Handles**  
**Hojas de bisturí y mangos de bisturí**  
**Lames de bistouris et manches pour bistouris**  
**Lame per bisturi e manici per bisturi**

**A01**

1:1

 **STERILE**





Fig. 20 **01.22.20** P 





Fig. 21 **01.22.21** P 







Fig. 25 **01.22.25** P 



13,5 cm – 5<sup>3</sup>/<sub>8</sub>" **01.28.04** no. 4



21 cm – 8<sup>1</sup>/<sub>4</sub>" **01.28.14** no. 4L



22,5 cm – 9" **01.28.45**

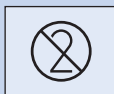

Einmalprodukt  
 Single use product  
 Prodotto para un solo uso  
 Produit à usage unique  
 Prodotto monouso

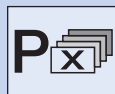

Verpackungseinheit "X" Stück  
 Packing unit "X" pieces  
 Paquete de "X" unidades  
 Emballage de "X" pièces  
 Confezione da "X" pezzi



**Skalpellklingen und Skalpellgriffe**  
**Scalpel Blades and Scalpel Handles**  
**Hojas de bisturí y mangos de bisturí**  
**Lames de bistouris et manches pour bistouris**  
**Lame per bisturi e manici per bisturi**

A01



1:1



Fig. 62 **01.30.62** P<sub>12</sub>



Fig. 64 **01.30.64** P<sub>12</sub>



Fig. 65 **01.30.65** P<sub>12</sub>



Fig. 67 **01.30.67** P<sub>12</sub>







Fig. 69 **01.30.69** P<sub>12</sub>

 **STERILE**



15,5 cm – 6 1/8" **01.30.36**



18 cm – 7 1/8" **01.30.37**



95 mm

21 cm – 8 1/4" **01.27.21** **Landolt**



140 mm

25 cm – 10" **01.27.25** **Landolt**



Einmalprodukt  
 Single use product  
 Producto para un solo uso  
 Produit à usage unique  
 Prodotto monouso

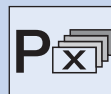

Verpackungseinheit "X" Stück  
 Packing unit "X" pieces  
 Paquete de "X" unidades  
 Emballage de "X" pièces  
 Confezione da "X" pezzi

Von "standard" bis "magic cut" – alle Scheren werden von fachkundigen Chirurgiemechanikern hergestellt. Sie werden für dauerhafte Leistung sorgfältig gehärtet und qualitätsgerecht geprüft.

Starting with "standard" up to "magic cut" – all scissors are manufactured by experienced professionals. They are thoroughly hardened to ensure a long-lasting performance and are quality-checked.

Desde tijeras "standard" hasta "magic cut" – todas las tijeras son fabricadas por expertos competentes. Las tijeras son templadas e investigadas respecto la calidad para un durable rendimiento.

De "standard" à "magic cut" – tous les ciseaux sont fabriqués par des mécaniciens de chirurgie compétents. Ils sont trempés soigneusement afin d'obtenir une performance durable et passent un contrôle de qualité.

Dalla "standard" alla "magic cut" – tutte le forbici sono prodotte da meccanici chirurgici specializzati. Per una lunga durata sono temprate accuratamente e devono passare il controllo di qualità.



**451.03.23**

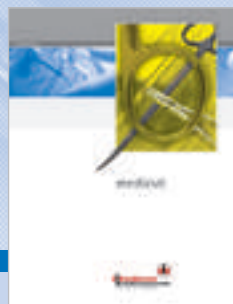

Unser komplettes Scheren-Programm finden Sie in unserem Sonderprospekt.  
For our complete line of scissors, see our special brochure.  
El programa completo de tijeras se encuentra en nuestro folleto especial.  
Vous trouverez notre gamme complète de ciseaux dans notre brochure spécial.  
Troverete il nostro programma completo di forbici nel nostro depliant speciale.



A02

**Farbcodierung**  
**Color Coding**  
**Codificación de color**  
**Codage de couleur**  
**Codice colore**

## supercut

Goldene Schraube  
Golden screw  
Tornillo dorado  
Vis dorée  
Vite dorata



## black line

Goldene Schraube und schwarze Ringgriffe  
Golden screw and black rings  
Tornillo dorado y anillos negros  
Vis dorée et anneaux noirs  
Vite dorata e anelli neri



## "HM"

Goldene Ringgriffe  
Golden rings  
Anillos dorados  
Anneaux dorés  
Anelli dorati



## supercut plus

Goldene Schraube und goldene Ringgriffe  
Golden screw and golden rings  
Tornillo dorado y anillos dorados  
Vis dorée et anneaux dorés  
Vite dorata e anelli dorati

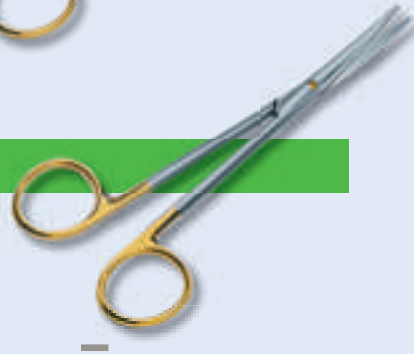

## magic cut

Keramikbeschichtung und goldene Schraube  
Ceramic coating and golden screw  
Recubrimiento de cerámica y tornillo dorado  
Couche céramique et vis dorée  
Rivestimento di ceramica e vite dorata



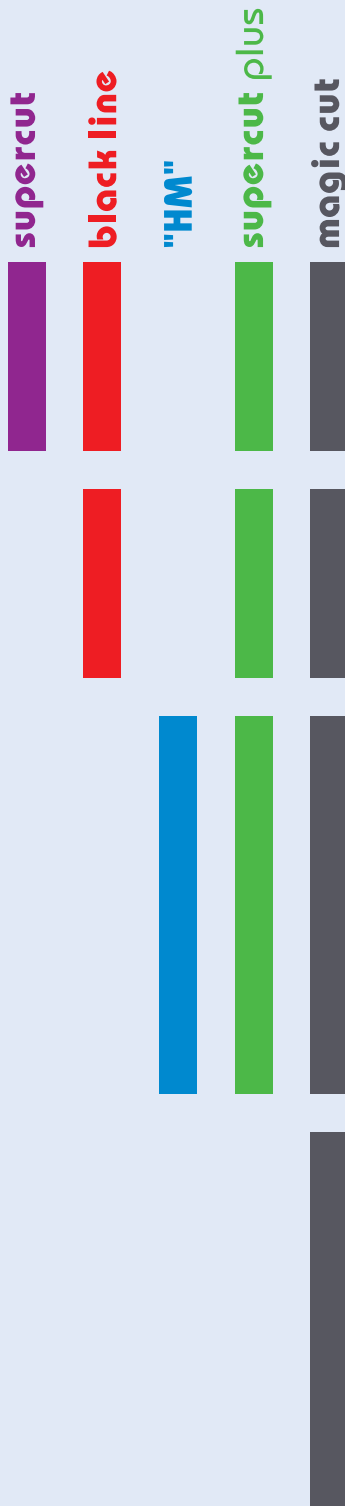

**Messerschliff und Mikroverzahnung:** Feiner, minimal traumatisierender Schnitt  
**Knife edges and micro serration:** Fine, minimally traumatizing cut  
**Hoja de bisturí y dentadura micro:** Corte fino, mínimo traumatizante  
**Aiguisement tranchant et dents micro:** Coupe fine, peu traumatisante  
**Affilatura a scalpello e dentellatura micro:** Taglio fine, minimamente traumatizzante

**Zusätzlicher Anschlag einer Blattrückseite:** Bessere Sicht · Präzise Präparation  
**Reduction of the transversal cut:** Better visibility · Precise dissection  
**Reducción del corte transversal:** Visión mejorada · Disección precisa  
**Coupe transversale réduite:** Vue améliorée · Dissection précise  
**Riduzione del taglio trasversale:** Vista migliorata · Dissezione precisa

**Eingeschweißte Hartmetallschneiden:** Nahtlose, homogene und korrosionsfreie Verbindung von Hartmetall und Scherenstahl  
**Welded tungsten carbide cutting edges:** Seamless, homogenous and corrosion-free junction of tungsten carbide and scissors steel  
**Hojas soldadas de carburo de tungsteno:** Unión sin costuras, homogénea y resistente a la corrosión del carburo de tungsteno con el acero  
**Lames soudées d'un alliage de carbure de tungstène:** Jointure sans trace, homogène et résistante à la corrosion du carbure de tungstène avec l'acier des ciseaux  
**Lame saldate al carburo di tungsteno:** Congiunzione senza saldature, omogenea e resistente alla corrosione del carburo di tungsteno e all'acciaio delle forbici

**Keramikbeschichtung:** Lange Standzeit · Hohe Oberflächenhärte · Blendfreie Oberfläche · Hervorragende Gleitfähigkeit  
**Ceramic coating:** Long lasting cutting ability · High surface hardness · Non-dazzling surface · Excellent sliding capacity  
**Recubrimiento de cerámica:** Máxima duración del corte · Alta dureza de la superficie · Superficie antideslumbrante · Deslizamiento destacado  
**Couche céramique:** Longue durée de vie · Grande dureté de la surface · Surface non-éblouissante · Glissement excellent  
**Rivestimento di ceramica:** Massima durata del taglio · Alta durezza della superficie · Superficie antiriflesso · Eccellente scorrimento

**A02**

**Feine Schere und chirurgische Scheren**  
**Delicate Scissors and Operating Scissors**  
**Tijera fina y tijeras quirúrgicas**  
**Ciseaux délicat et ciseaux chirurgicaux**  
**Forbice delicata e forbici chirurgiche**



Feine Schere  
 Delicate scissors  
 Tijera fina  
 Ciseaux délicat  
 Forbice delicata

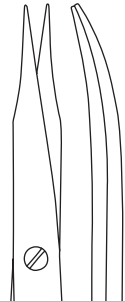

13 cm – 5 1/8"

**02.50.45****standard**

Chirurgische Scheren  
 Operating scissors  
 Tijeras quirúrgicas  
 Ciseaux chirurgicaux  
 Forbici chirurgiche

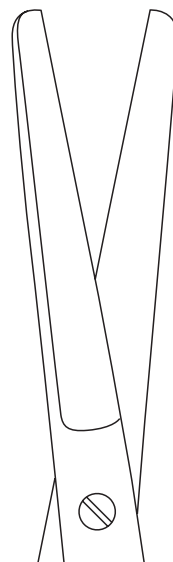
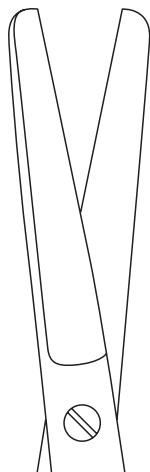

14,5 cm – 5 3/4"

14,5 cm – 5 3/4"

16,5 cm – 6 1/2"

16,5 cm – 6 1/2"





**03.02.14****03.03.14****03.02.16****03.03.16****standard****203.02.14****203.03.14****203.02.16****203.03.16****supercut****213.02.14****213.03.14****black line****03.02.64****03.03.64****"HM"**





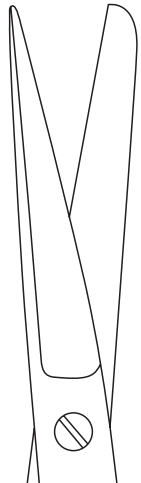

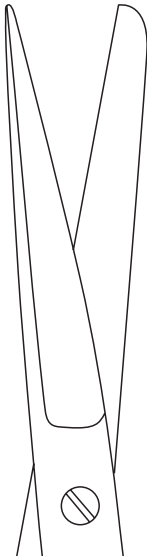
**Chirurgische Scheren**  
**Operating Scissors**  
**Tijeras quirúrgicas**  
**Ciseaux chirurgicaux**  
**Forbici chirurgiche**

**A02**

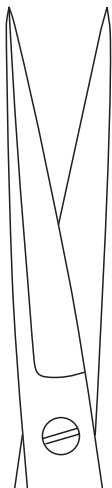

				
14,5 cm – 5¾"	14,5 cm – 5¾"	16,5 cm – 6½"	16,5 cm – 6½"	
<b>03.06.14</b>	<b>03.07.14</b>	<b>03.06.16</b>	<b>03.07.16</b>	<b>standard</b>
<b>203.06.14</b>	<b>203.07.14</b>	<b>203.06.16</b>		<b>supercut</b>
<b>213.06.14</b>	<b>213.07.14</b>			<b>black line</b>
<b>03.06.64</b>	<b>03.07.64</b>			<b>"HM"</b>

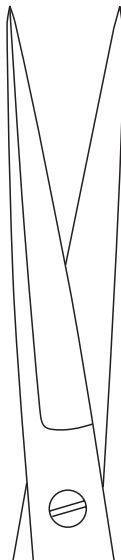

				
14,5 cm – 5¾"	14,5 cm – 5¾"	16,5 cm – 6½"	16,5 cm – 6½"	
<b>03.04.14</b>	<b>03.05.14</b>	<b>03.04.16</b>	<b>03.05.16</b>	<b>standard</b>
<b>203.04.14</b>	<b>203.05.14</b>			<b>supercut</b>
<b>213.04.14</b>	<b>213.05.14</b>			<b>black line</b>
<b>03.04.64</b>	<b>03.05.64</b>			<b>"HM"</b>



**Chirurgische Scheren**  
**Operating Scissors**  
**Tijeras quirúrgicas**  
**Ciseaux chirurgicaux**  
**Forbici chirurgiche**

**A02**





14,5 cm – 5¾"	14,5 cm – 5¾"	
<b>03.04.84</b>	<b>03.05.84</b>	<b>standard</b>





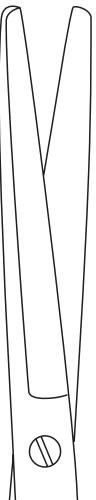

14,5 cm – 5¾"	14,5 cm – 5¾"	
<b>03.06.84</b>	<b>03.07.84</b>	<b>standard</b>



		
14,5 cm – 5¾"	14,5 cm – 5¾"	
<b>03.02.84</b>	<b>03.03.84</b>	<b>standard</b>

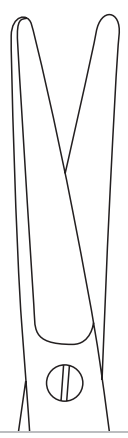

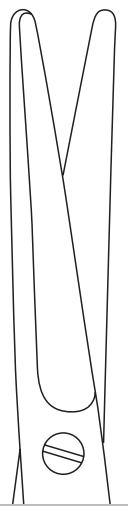
**Mayo**

				
14,5 cm – 5¾"	14,5 cm – 5¾"	17 cm – 6¾"	17 cm – 6¾"	
<b>03.50.14</b>	<b>03.51.14</b>	<b>03.50.17</b>	<b>03.51.17</b>	<b>standard</b>
<b>203.50.14</b>	<b>203.51.14</b>	<b>203.50.17</b>	<b>203.51.17</b>	<b>supercut</b>
<b>213.50.14</b>	<b>213.51.14</b>	<b>213.50.17</b>	<b>213.51.17</b>	<b>black line</b>
<b>03.50.64</b>	<b>03.51.64</b>	<b>03.50.67</b>	<b>03.51.67</b>	<b>"HM"</b>
<b>203.50.64</b>	<b>203.51.64</b>	<b>203.50.67</b>	<b>203.51.67</b>	<b>supercut plus</b>

**A02**

**Feine Präparierscheren**  
**Delicate Dissecting Scissors**  
**Tijeras finas para disección**  
**Ciseaux délicats pour dissection**  
**Forbici delicate per dissezione**

21  
8  
20  
19  
18  
7  
17  
16  
6  
15  
14  
5  
13  
12  
11  
4  
10  
9  
3  
8  
7  
6  
2  
5  
4  
3  
1  
2  
1  
cm | inch

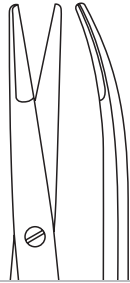
**Greenberg PAR**

11,5 cm – 4½"	
<b>204.13.62</b>	<b>supercut plus</b>
<b>224.13.62</b>	<b>magic cut</b>

**Shea**

12 cm – 4¾"	
<b>04.13.12</b>	<b>standard</b>
<b>204.13.12</b>	<b>supercut</b>
<b>214.13.12</b>	<b>black line</b>

**Feine Präparierscheren**  
**Delicate Dissecting Scissors**  
**Tijeras finas para disección**  
**Ciseaux délicats pour dissection**  
**Forbici delicate per dissezione**

**A02**



**"slim"**

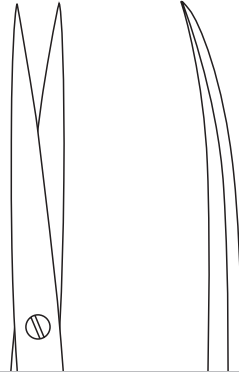

14 cm – 5½"	14 cm – 5½"	
<b>04.24.14</b>	<b>04.25.14</b>	standard
<b>204.24.14</b>	<b>204.25.14</b>	supercut
<b>04.24.64</b>	<b>04.25.64</b>	"HM"
<b>204.24.64</b>	<b>204.25.64</b>	supercut plus



**Baby-Metzenbaum**

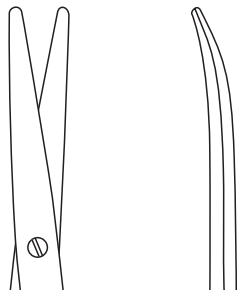

11,5 cm – 4½"	11,5 cm – 4½"	
<b>04.32.11</b>	<b>04.33.11</b>	standard
<b>204.32.11</b>	<b>204.33.11</b>	supercut
<b>214.32.11</b>	<b>214.33.11</b>	black line
<b>04.32.61</b>	<b>04.33.61</b>	"HM"
<b>204.32.61</b>	<b>204.33.61</b>	supercut plus



**Präparierscheren**  
**Dissecting Scissors**  
**Tijeras para disección**  
**Ciseaux pour dissection**  
**Forbici per dissezione**

A02



Metzenbaum

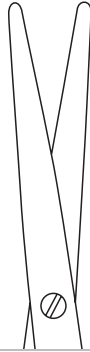

14 cm – 5½"	18 cm – 7⅛"	20 cm – 8"	
<b>04.32.14</b>	<b>04.32.18</b>	<b>04.32.20</b>	standard
<b>204.32.14</b>	<b>204.32.18</b>	<b>204.32.20</b>	supercut
<b>214.32.14</b>	<b>214.32.18</b>	<b>214.32.20</b>	black line
<b>04.32.64</b>	<b>04.32.68</b>	<b>04.32.70</b>	"HM"
<b>204.32.64</b>	<b>204.32.68</b>	<b>204.32.70</b>	supercut plus



Metzenbaum



14 cm – 5½"	18 cm – 7⅛"	20 cm – 8"	
<b>04.33.14</b>	<b>04.33.18</b>	<b>04.33.20</b>	standard
<b>204.33.14</b>	<b>204.33.18</b>	<b>204.33.20</b>	supercut
<b>214.33.14</b>	<b>214.33.18</b>	<b>214.33.20</b>	black line
<b>04.33.64</b>	<b>04.33.68</b>	<b>04.33.70</b>	"HM"
<b>204.33.64</b>	<b>204.33.68</b>	<b>204.33.70</b>	supercut plus

**Präparierscheren**  
**Dissecting Scissors**  
**Tijeras para disección**  
**Ciseaux pour dissection**  
**Forbici per dissezione**

**A02**



**Metzenbaum-slim**

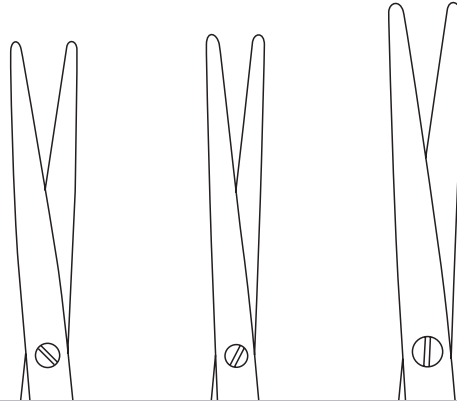

14 cm – 5½"	18 cm – 7⅛"	20 cm – 8"	
<b>04.34.14</b>	<b>04.34.18</b>	<b>04.34.20</b>	standard
<b>204.34.14</b>	<b>204.34.18</b>	<b>204.34.20</b>	supercut
<b>214.34.14</b>	<b>214.34.18</b>	<b>214.34.20</b>	black line
<b>04.34.64</b>	<b>04.34.68</b>	<b>04.34.70</b>	"HM"
<b>204.34.64</b>	<b>204.34.68</b>	<b>204.34.70</b>	supercut plus



**Metzenbaum-slim**

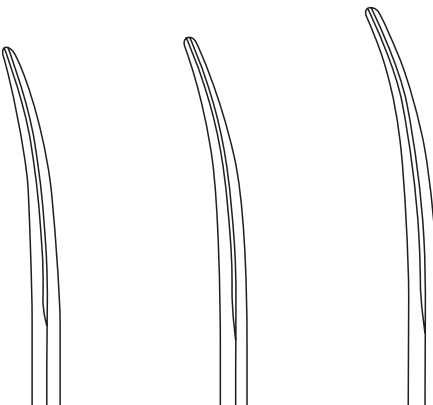

14 cm – 5½"	18 cm – 7⅛"	20 cm – 8"	
<b>04.35.14</b>	<b>04.35.18</b>	<b>04.35.20</b>	standard
<b>204.35.14</b>	<b>204.35.18</b>	<b>204.35.20</b>	supercut
<b>214.35.14</b>	<b>214.35.18</b>	<b>214.35.20</b>	black line
<b>04.35.64</b>	<b>04.35.68</b>	<b>04.35.70</b>	"HM"
<b>204.35.64</b>	<b>204.35.68</b>	<b>204.35.70</b>	supercut plus



**Präparierscheren**  
**Dissecting Scissors**  
**Tijeras para disección**  
**Ciseaux pour dissection**  
**Forbici per dissezione**

**A02**



**Reynolds (Jameson)**

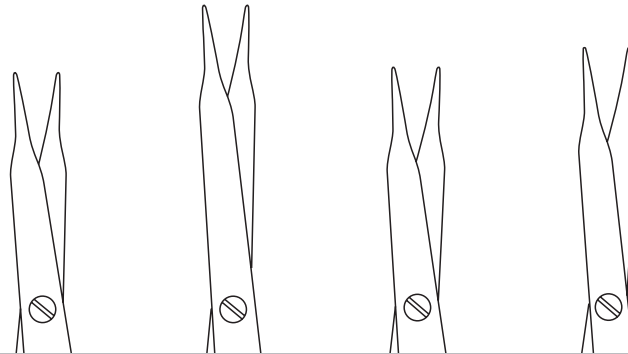

12 cm – 4¾"	14 cm – 5½"	16 cm – 6¼"	18 cm – 7⅛"	
<b>04.66.12</b>	<b>04.66.14</b>	<b>04.66.16</b>	<b>04.66.18</b>	<b>standard</b>



**Reynolds (Jameson)**

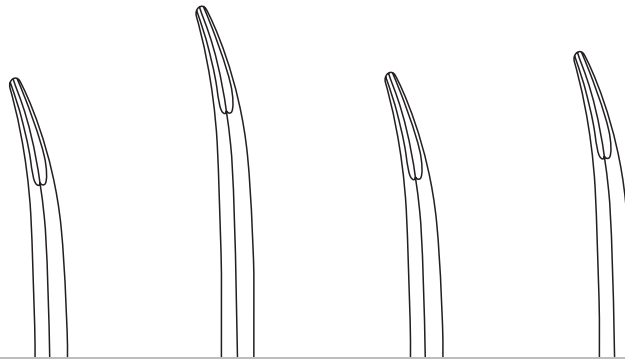

12 cm – 4¾"	14 cm – 5½"	16 cm – 6¼"	18 cm – 7⅛"	
<b>04.67.12</b>	<b>04.67.14</b>	<b>04.67.16</b>	<b>04.67.18</b>	<b>standard</b>
<b>204.67.12</b>		<b>204.67.16</b>	<b>204.67.18</b>	<b>supercut</b>
<b>214.67.12</b>		<b>214.67.16</b>	<b>214.67.18</b>	<b>black line</b>
		<b>224.67.66</b>	<b>224.67.68</b>	<b>magic cut</b>



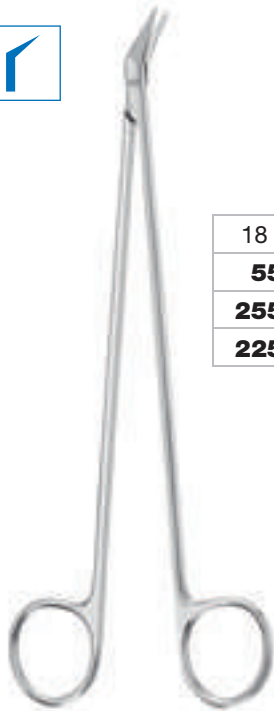

Hegemann-Diethrich

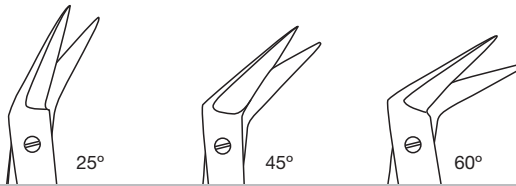

18 cm – 7 1/8"	18 cm – 7 1/8"	18 cm – 7 1/8"	
<b>55.15.32</b>	<b>55.15.34</b>	<b>55.15.36</b>	standard
<b>255.15.32</b>	<b>255.15.34</b>	<b>255.15.36</b>	supercut
<b>225.15.32</b>	<b>225.15.34</b>	<b>225.15.36</b>	magic cut



Potts-Smith

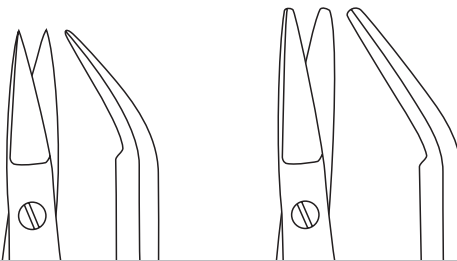

19 cm – 7 1/2"	19 cm – 7 1/2"	
<b>55.15.50</b>	<b>55.15.51</b>	standard



seitwärts gewinkelt  
 angled to side  
 acodadas lateralmente  
 coudés latéralement  
 angolata lateralmente



**Gefäßscheren und Mikro-Scheren**  
**Vascular Scissors and Micro Scissors**  
**Tijeras vasculares y micro tijeras**  
**Ciseaux vasculaires et micro ciseaux**  
**Forbici vascolari e micro forbici**

A02

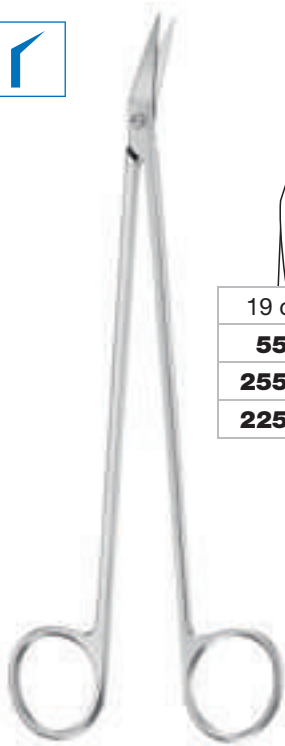

Potts-Smith



25°

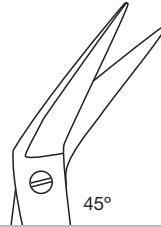

45°

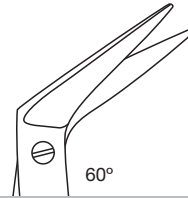

60°

19 cm - 7½"	19 cm - 7½"	19 cm - 7½"	
<b>55.15.42</b>	<b>55.15.44</b>	<b>55.15.46</b>	<b>standard</b>
<b>255.15.42</b>	<b>255.15.44</b>	<b>255.15.46</b>	<b>supercut</b>
<b>225.15.42</b>	<b>225.15.44</b>	<b>225.15.46</b>	<b>magic cut</b>

## VANNAS



8 mm



15 cm - 6"

**05.15.74****205.15.74**

15 cm - 6"

**05.15.75**

15 cm - 6"

**05.15.76**

15 cm - 6"

**05.15.77**

15 cm - 6"	15 cm - 6"	15 cm - 6"	15 cm - 6"	
<b>05.15.74</b>	<b>05.15.75</b>	<b>05.15.76</b>	<b>05.15.77</b>	<b>standard</b>
<b>205.15.74</b>				<b>supercut</b>



Rundgriff  
 Round handle  
 Mango redondo  
 Manche rond  
 Manico rotondo



seitwärts gewinkelt  
 angled to side  
 acodadas lateralmente  
 coudés latéralement  
 angolata lateralmente



Vannas-Schneiden  
 Vannas-type cutting edges  
 Hojas según Vannas  
 Lames selon Vannas  
 Lame secondo Vannas



micro 2000

15 cm – 6"	15 cm – 6"	18 cm – 7 1/8"	18 cm – 7 1/8"	
<b>05.15.70</b>	<b>05.15.71</b>	<b>05.18.70</b>	<b>05.18.71</b>	<b>standard</b>
		<b>205.18.70</b>	<b>205.18.71</b>	<b>supercut</b>



15 cm – 6"	15 cm – 6"	18 cm – 7 1/8"	18 cm – 7 1/8"	
<b>05.15.72</b>	<b>05.15.73</b>	<b>05.18.72</b>	<b>05.18.73</b>	<b>standard</b>



15 cm – 6"	15 cm – 6"	18 cm – 7 1/8"	18 cm – 7 1/8"	
<b>05.15.81</b>	<b>05.15.83</b>	<b>05.18.81</b>	<b>05.18.83</b>	<b>standard</b>



Instrumente mit blau eloxierten Leichtmetall-Griffen für höchste Präzision und Arbeitskomfort.

Instruments with blue anodized light metal handles for maximum precision and working convenience.

Instrumentos con mangos de metal ligero anodizados en azul para la precisión y el confort de trabajo máximo.

Instruments avec manches en métal léger anodisés en bleu pour un maximum de précision et de confort à l'utilisation.

Strumenti con manici di metallo leggero anodizzati blu per una precisione massima e conforto lavorativo.



Eine Schneide gezahnt  
 One blade serrated  
 Una hoja dentada  
 Une lame dentelée  
 Una lama dentellata



spitz  
 sharp  
 aguda  
 pointu  
 acuta



stumpf  
 blunt  
 roma  
 mousse  
 smussa



**Mikro-Scheren**  
**Micro Scissors**  
**Micro tijeras**  
**Micro ciseaux**  
**Micro forbici**

**A02**

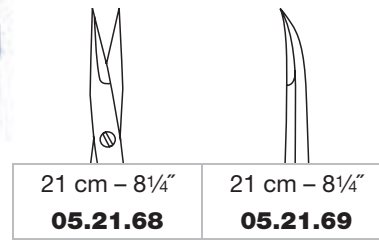
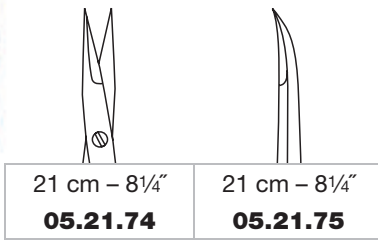
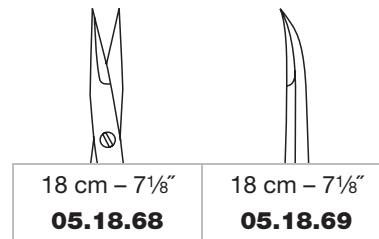
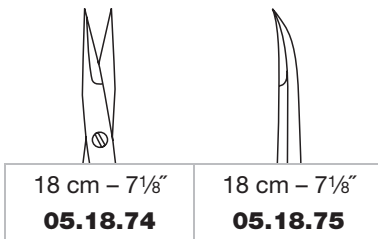
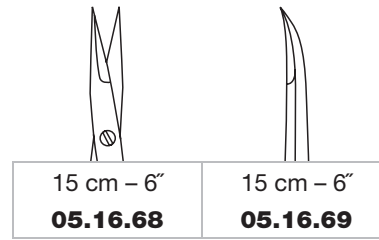
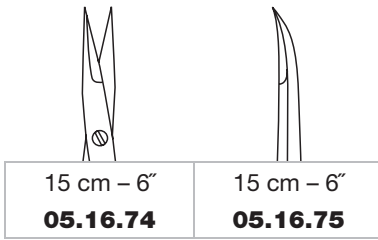

Tumorscheren  
Tumor scissors  
Tijeras para tumores  
Ciseaux pour tumeur  
Forbici per tumori

— a —

gerade straight recta droit retta	rechts gebogen curved right curva derecha courbé à droite curva a destra	links gebogen curved left curva izquierda courbé à gauche curva a sinistra
8 mm	8 mm	8 mm
a = 12,5 cm - 5"	a = 12,5 cm - 5"	a = 12,5 cm - 5"
<b>58.46.40</b>	<b>58.46.42</b>	<b>58.46.43</b>

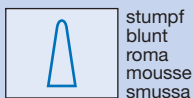
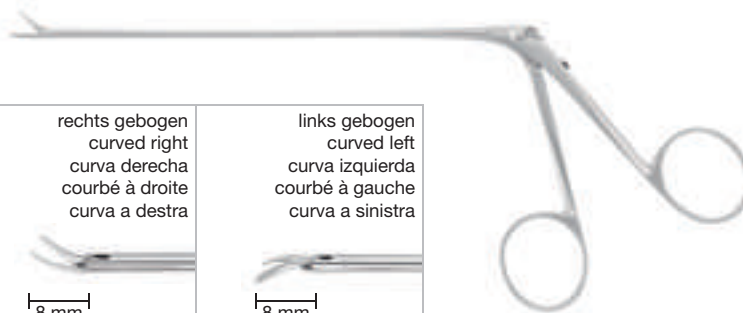

stumpf  
blunt  
roma  
mousse  
smussa













Rundgriff  
Round handle  
Mango redondo  
Manche rond  
Manico rotondo

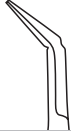

Titan  
Titanium  
Titanio  
Titane  
Titanio









**VANNAS**



				
12 cm – 4¾"	12 cm – 4¾"	12 cm – 4¾"	12 cm – 4¾"	12 cm – 4¾"
<b>05.18.84</b>	<b>05.18.85</b>	<b>05.18.86</b>	<b>05.18.87</b>	<b>05.18.89</b>
				

**VANNAS**



			
16 cm – 6¼"	16 cm – 6¼"	16 cm – 6¼"	16 cm – 6¼"
<b>05.18.92</b>	<b>05.18.93</b>	<b>05.18.94</b>	<b>05.18.95</b>
			



13 cm – 5¼"
<b>05.18.90</b>

**Biemer**



spitz  
sharp  
aguda  
pointu  
acuta



Vannas-Schneiden  
Vannas-type cutting edges  
Hojas según Vannas  
Lames selon Vannas  
Lame secondo Vannas



**Mikro-Scheren**  
**Micro Scissors**  
**Micro tijeras**  
**Micro ciseaux**  
**Micro forbici**

**A02**



**Millesi**



16 cm – 6 1/4"  
**05.18.96**



16 cm – 6 1/4"  
**05.18.97**



**Yasargil**



18,5 cm – 7 1/4"  
**05.18.98**



**Jacobson**



18,5 cm – 7 1/4"  
**05.18.99**



**Potts-Yasargil**



18,5 cm – 7 1/4"  
**05.19.01**



seitwärts gewinkelt  
angled to side  
acodadas lateralmente  
coudés latéralement  
angolata lateralmente



Eine Schneide gezahnt  
One blade serrated  
Una hoja dentada  
Une lame dentelée  
Una lama dentellata



spitz  
sharp  
aguda  
pointu  
acuta

**Mikro-Scheren**  
**Micro Scissors**  
**Micro tijeras**  
**Micro ciseaux**  
**Micro forbici**

**A02**



23 cm - 9"  
**05.19.02**



8 mm



18,5 cm - 7¼"  
**05.19.10**



18 cm - 7⅞"  
**05.19.25**  
**225.19.25**



18 cm - 7⅞"  
**05.19.45**  
**225.19.45**



18 cm - 7⅞"  
**05.19.60**  
**225.19.60**



18 cm - 7⅞"	18 cm - 7⅞"	18 cm - 7⅞"	
<b>05.19.25</b>	<b>05.19.45</b>	<b>05.19.60</b>	<b>"HM"</b>
<b>225.19.25</b>	<b>225.19.45</b>	<b>225.19.60</b>	<b>magic cut</b>

seitwärts gewinkelt  
 angled to side  
 acodadas lateralmente  
 coudés latéralement  
 angolata lateralmente

spitz  
 sharp  
 aguda  
 pointu  
 acuta

stumpf  
 blunt  
 roma  
 mousse  
 smussa

Rundgriff  
 Round handle  
 Mango redondo  
 Manche rond  
 Manico rotondo



**Mikro-Scheren**  
**Micro Scissors**  
**Micro tijeras**  
**Micro ciseaux**  
**Micro forbici**

**A02**



**Yasargil**



Instrumente mit blau eloxierten Leichtmetall-Griffen für höchste Präzision und Arbeitskomfort.

Instruments with blue anodized light metal handles for maximum precision and working convenience.

Instrumentos con mangos de metal ligero anodizados en azul para la precisión y el confort de trabajo máximo.

Instruments avec manches en métal léger anodisés en bleu pour un maximum de précision et de confort à l'utilisation.

Strumenti con manici di metallo leggero anodizzati blu per una precisione massima e conforto lavorativo.

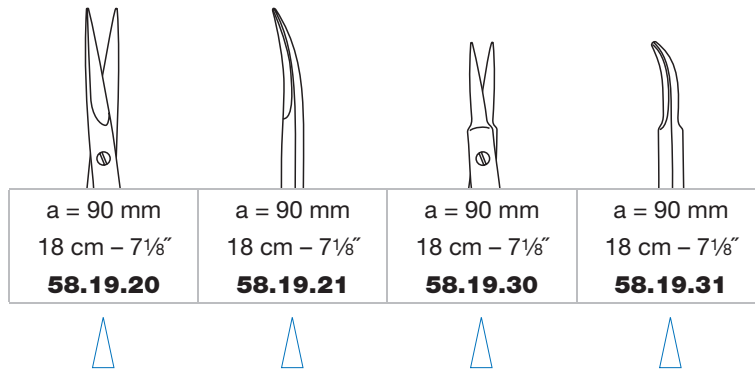

a = 90 mm 18 cm - 7 1/8"	a = 90 mm 18 cm - 7 1/8"	a = 90 mm 18 cm - 7 1/8"	a = 90 mm 18 cm - 7 1/8"
<b>58.19.20</b>	<b>58.19.21</b>	<b>58.19.30</b>	<b>58.19.31</b>



**micro 2000**

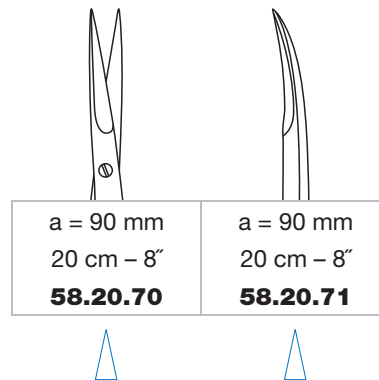

a = 90 mm 20 cm - 8"	a = 90 mm 20 cm - 8"
<b>58.20.70</b>	<b>58.20.71</b>





spitz  
sharp  
aguda  
pointu  
acuta







**Yasargil**



	
a = 55 mm 16 cm – 6¼"	a = 55 mm 16 cm – 6¼"
<b>59.16.20</b>	<b>59.16.21</b>



**Yasargil**

		
a = 85 mm 20 cm – 8"	a = 85 mm 20 cm – 8"	a = 85 mm 20 cm – 8"
<b>59.20.20</b>	<b>59.20.21</b>	<b>59.20.23</b>



	
a = 85 mm 20 cm – 8"	a = 85 mm 20 cm – 8"
<b>59.20.30</b>	<b>59.20.31</b>

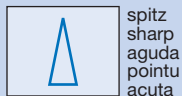

spitz  
sharp  
aguda  
pointu  
acuta



stumpf  
blunt  
roma  
mousse  
smussa



**Mikro-Scheren**  
**Micro Scissors**  
**Micro tijeras**  
**Micro ciseaux**  
**Micro forbici**

**A02**

**VANNAS**



**Yasargil**

a



a = 105 mm  
23 cm - 9"  
**59.23.20**



a = 105 mm  
23 cm - 9"  
**59.23.21**



a = 105 mm  
23 cm - 9"  
**59.23.30**



a = 105 mm  
23 cm - 9"  
**59.23.31**



**Yasargil**

a



a = 105 mm  
23 cm - 9"  
**59.23.40**



a = 105 mm  
23 cm - 9"  
**59.23.41**



spitz  
sharp  
aguda  
pointu  
acuta



stumpf  
blunt  
roma  
mousse  
smussa

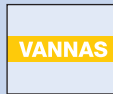

Vannas-Schneiden  
Vannas-type cutting edges  
Hojas según Vannas  
Lames selon Vannas  
Lame secondo Vannas

**Duraschere und Trigeminschere**  
**Dura Scissors and Trigeminal Scissors**  
**Tijera para duramadre y tijeras para trigémino**  
**Ciseaux pour dure-mère et ciseaux pour trijumeau**  
**Forbice per dura madre e forbici per trigemino**

**A02**

Duraschere  
 Dura scissors  
 Tijera para duramadre  
 Ciseaux pour dure-mère  
 Forbice per dura madre

Trigeminschere  
 Trigeminal scissors  
 Tijera para trigémino  
 Ciseaux pour trijumeau  
 Forbice per trigemino



**Schmieden (Taylor)**



**Strully**

Trigeminschere  
 Trigeminal scissors  
 Tijera para trigémino  
 Ciseaux pour trijumeau  
 Forbice per trigemino

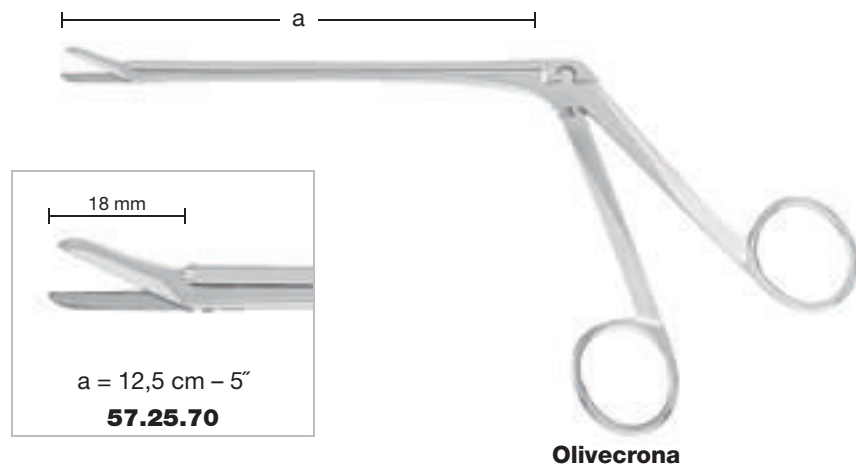

**Olivecrona**

seitwärts gewinkelt  
 angled to side  
 acodadas lateralmente  
 coudés latéralement  
 angolata lateralmente



A02

**Ligaturscheren, Draht- und Mesh-Plattenscheren**  
**Ligature Scissors, Wire and Mesh Plate Cutting Scissors**  
**Tijeras para ligaduras, tijeras para cortar alambre y placas Mesh**  
**Ciseaux à ligature, ciseaux coupe-fil et coupe-plaques Mesh**  
**Forbici per legature, forbici per fili d'acciaio e placche Mesh**

21  
8  
20  
19  
18  
17  
16  
15  
14  
13  
12  
11  
10  
9  
8  
7  
6  
5  
4  
3  
2  
1  
cm inch

Ligaturscheren  
 Ligature scissors  
 Tijeras para ligaduras  
 Ciseaux à ligature  
 Forbici per legature



"HM"

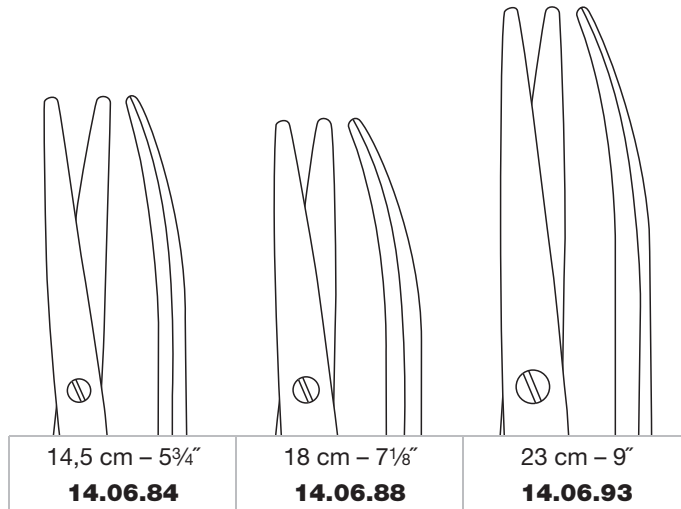

mit Mikroverzahnung und Hartmetallschneiden  
 with micro serration and tungsten carbide edges  
 con micro dientes y hojas de carburo tungsteno  
 avec denture micro et lames en carbure tungstène  
 con dentellatura micro e lame in carburo di tungsteno

Draht- und Mesh-Plattenscheren  
 Wire and Mesh plate cutting scissors  
 Tijeras para cortar alambre y placas Mesh  
 Ciseaux coupe-fil et coupe-plaques Mesh  
 Forbici per fili d'acciaio e placche Mesh

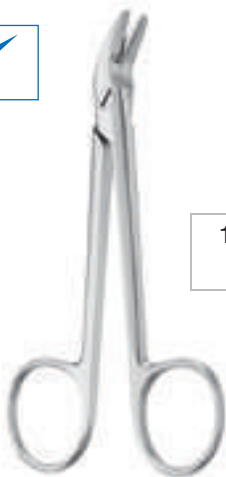

Universal

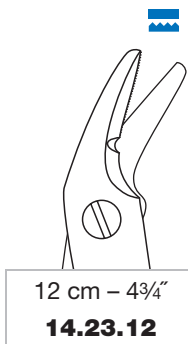

Universal "HM"

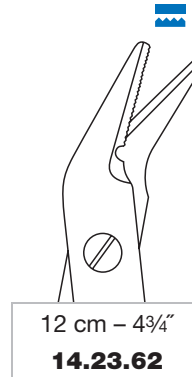

max.  
 Ø 0,3 mm  
 Harte Drähte  
 Hard wires  
 Alambres duros  
 Fils durs  
 Fili duri

max.  
 Ø 0,8 mm  
 Weiche Drähte  
 Soft wires  
 Alambres blandos  
 Fils mous  
 Fili dolci

"HM"

Hartmetall  
 Tungsten carbide  
 Carburo de tungsteno  
 Carbure de tungstène  
 Carburo di tungsteno



seitwärts gewinkelt  
 angled to side  
 acodadas lateralmente  
 coudés latéralement  
 angolata lateralmente



Eine Schneide gezahnt  
 One blade serrated  
 Una hoja dentada  
 Une lame dentelée  
 Una lama dentellata



**Pinzetten**  
**Forceps**  
**Pinzas**  
**Pinces**  
**Pinze**

**A03**

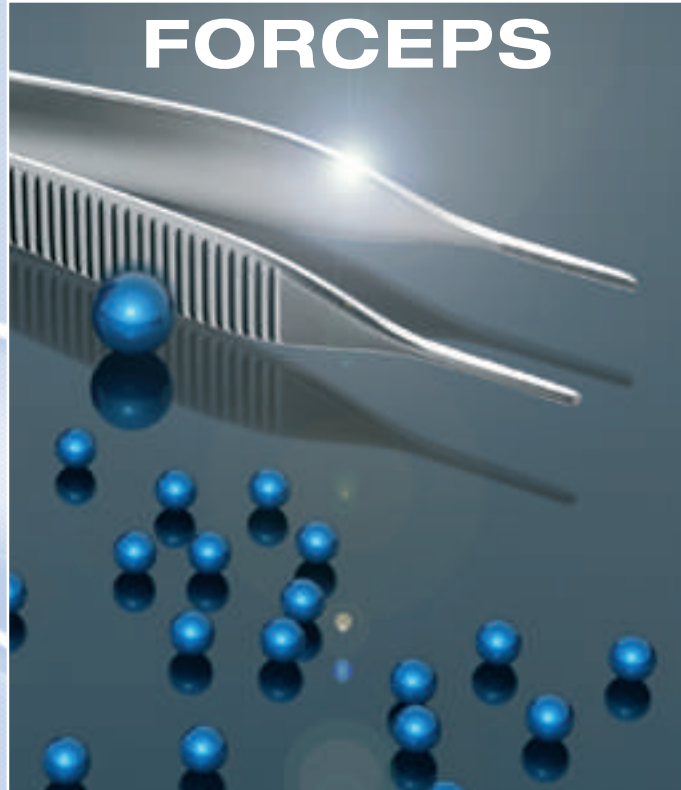



# A03

**Feine Pinzetten, anatomisch und chirurgisch**  
**Delicate Forceps, dressing and tissue**  
**Pinzas finas, anatómicas y quirúrgicas**  
**Pinces délicates, anatomiques et chirurgicales**  
**Pinze delicate, anatomiche e chirurgiche**



**Adson**

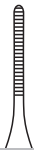

12 cm – 4¾"  
**06.20.12**



**Adson**



12 cm – 4¾"  
**06.21.12**



12 cm – 4¾"  
**06.21.13**



**Adson "HM"**



12 cm – 4¾"  
**06.20.62**



12 cm – 4¾"  
**06.21.62**



**Adson "HM"**



15 cm – 6"  
**06.20.65**



15 cm – 6"  
**06.21.65**



**Micro-Adson**



12 cm – 4¾"  
**06.22.12**



12 cm – 4¾"  
**06.23.12**



**Micro-Adson**



15 cm – 6"  
**06.22.15**



15 cm – 6"  
**06.23.15**

**"HM"**

Hartmetall  
 Tungsten carbide  
 Carburo de tungsteno  
 Carbure de tungstène  
 Carburo di tungsteno





Vergrößerung  
 Magnification  
 Engrandecimiento  
 Agrandissement  
 Ingrandimento

**Feine Pinzetten, anatomisch und chirurgisch**  
**Delicate Forceps, dressing and tissue**  
**Pinzas finas, anatómicas y quirúrgicas**  
**Pinces délicates, anatomiques et chirurgicales**  
**Pinze delicate, anatomiche e chirurgiche**

**A03**





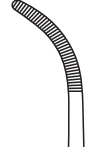

**Semken**

	
12,5 cm – 5" <b>06.30.12</b>	12,5 cm – 5" <b>06.30.22</b>
	
15 cm – 6" <b>06.30.15</b>	15 cm – 6" <b>06.30.25</b>





**Semken**

	
12,5 cm – 5" <b>06.31.12</b>	12,5 cm – 5" <b>06.31.22</b>
	
15 cm – 6" <b>06.31.15</b>	15 cm – 6" <b>06.31.25</b>







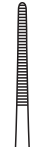

**Semken**

12,5 cm – 5" <b>06.31.32</b>

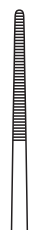

**"Select"**

		
15 cm – 6" <b>06.34.55</b>	18 cm – 7 1/8" <b>06.34.58</b>	20 cm – 8" <b>06.34.60</b>
		
15 cm – 6" <b>06.35.55</b>	18 cm – 7 1/8" <b>06.35.58</b>	20 cm – 8" <b>06.35.60</b>



**Anatomische und chirurgische Pinzetten**  
**Dressing and Tissue Forceps**  
**Pinzas anatómicas y quirúrgicas**  
**Pinces anatomiques et chirurgicales**  
**Pinze anatomiche e chirurgiche**

**A03**



**McIndoe**

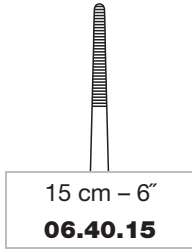

**Gillies**

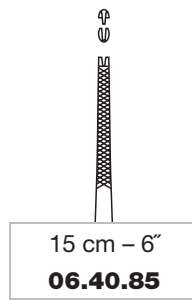

**Potts-Smith**

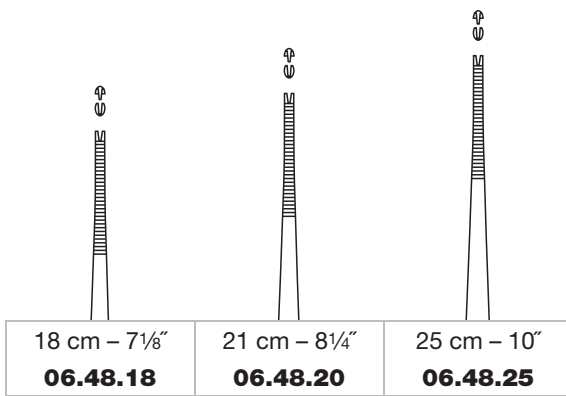
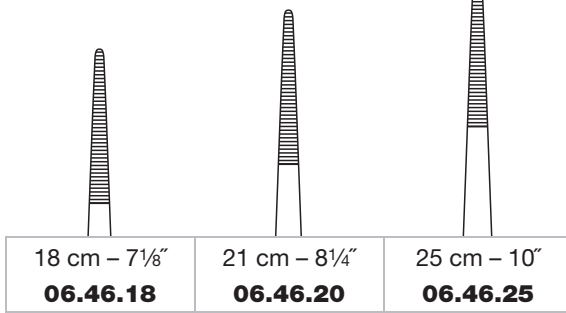



Anatomische und chirurgische Pinzetten  
 Dressing and Tissue Forceps  
 Pinzas anatómicas y quirúrgicas  
 Pinces anatomiques et chirurgicales  
 Pinze anatomiche e chirurgiche

A03

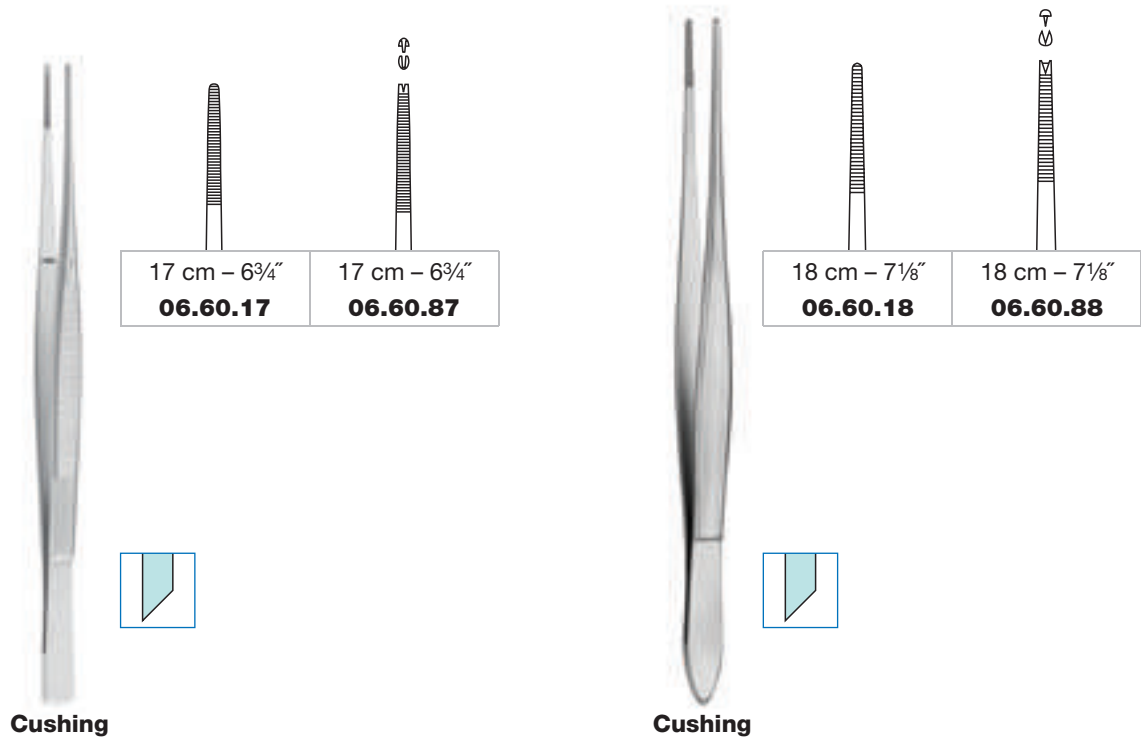

Cushing

Cushing

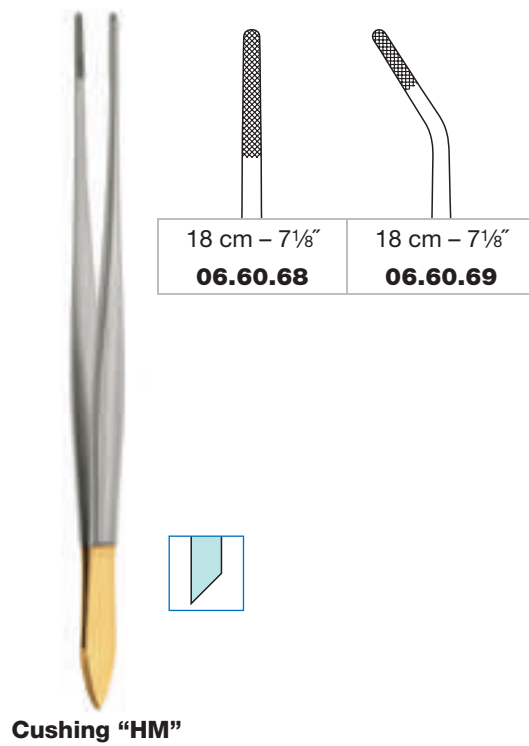

Cushing "HM"

"HM"  
 Hartmetall  
 Tungsten carbide  
 Carburo de tungsteno  
 Carbure de tungstène  
 Carburo di tungsteno

mit Dissektorende  
 with dissector end  
 con extremo sirviendo de legra  
 avec extrémité dissecteur  
 con la parte finale a forma di dissettore



**Atraumatische Gefäßpinzetten**  
**Atraumatic Vascular Forceps**  
**Pinzas vasculares atraumáticas**  
**Pinces vasculaires atraumatiques**  
**Pinze vascolari atraumatiche**

**A03**



**DeBakey "AT"**



1,5 mm

1,5 mm

1,5 mm

1,5 mm

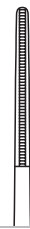
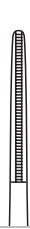
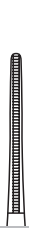

15 cm – 6"  
**06.50.15**

20 cm – 8"  
**06.50.19**

24 cm – 9½"  
**06.50.24**

30 cm – 11¾"  
**06.50.30**

2,0 mm

2,0 mm

2,0 mm

2,0 mm

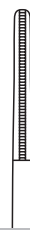
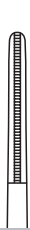
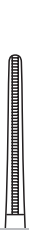

15 cm – 6"  
**06.52.15**

20 cm – 8"  
**06.52.19**

24 cm – 9½"  
**06.52.24**

30 cm – 11¾"  
**06.52.30**

2,8 mm

2,8 mm

2,8 mm

2,8 mm



15 cm – 6"  
**06.54.15**

20 cm – 8"  
**06.54.19**

24 cm – 9½"  
**06.54.24**

30 cm – 11¾"  
**06.54.30**

3,5 mm

3,5 mm

3,5 mm

3,5 mm

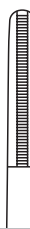
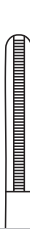
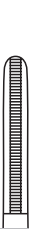

15 cm – 6"  
**06.55.15**

20 cm – 8"  
**06.55.19**

24 cm – 9½"  
**06.55.24**

30 cm – 11¾"  
**06.55.30**



**DeBakey "AT"**



**"AT"**  
 Atraumatische Riefung  
 Atraumatic serration  
 Estriás atraumáticas  
 Striure atraumatique  
 Zigrinatura atraumatica

**Atraumatische Gefäßpinzetten**  
**Atraumatic Vascular Forceps**  
**Pinzas vasculares atraumáticas**  
**Pinces vasculaires atraumatiques**  
**Pinze vascolari atraumatiche**

**A03**





2,4 mm

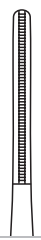

15 cm – 6"  
**06.62.15**

2,4 mm

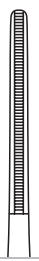

20 cm – 8"  
**06.62.19**

2,4 mm

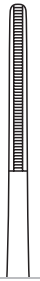

24 cm – 9½"  
**06.62.24**

2,8 mm

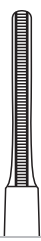

15 cm – 6"  
**06.64.15**

2,8 mm

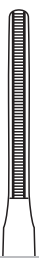

20 cm – 8"  
**06.64.19**

2,8 mm

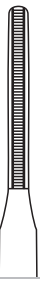



24 cm – 9½"  
**06.64.24**

**DeBakey "AT"**

Atraumatische Gefäßpinzetten  
 Atraumatic vascular forceps  
 Pinzas vasculares atraumáticas  
 Pinces vasculaires atraumatiques  
 Pinze vascolari atraumatiche

extrem leicht  
 extremely light  
 especialmente ligera  
 extrêmement légère  
 estremamente leggera





1,2 mm

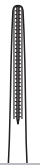

15 cm – 6"  
**06.51.15**

1,5 mm



20 cm – 8"  
**06.51.20**

**DeBakey "AT"**

**"AT"**  

 Atraumatische Riefung  
 Atraumatic serration  
 Estrias atraumáticas  
 Striure atraumatique  
 Zigrinatura atraumatica



**Atraumatische Pinzetten**  
**Atraumatic Forceps**  
**Pinzas atraumáticas**  
**Pinces atraumatiques**  
**Pinze atraumatiche**

**A03**



1,0 mm

1,0 mm

1,0 mm



15 cm – 6"  
**06.70.15**

20 cm – 8"  
**06.70.20**

24 cm – 9½"  
**06.70.24**

1,5 mm

1,5 mm

1,5 mm



15 cm – 6"  
**06.72.15**

20 cm – 8"  
**06.72.20**

24 cm – 9½"  
**06.72.24**

2,0 mm

2,0 mm

2,0 mm



15 cm – 6"  
**06.74.15**

20 cm – 8"  
**06.74.20**

24 cm – 9½"  
**06.74.24**



Titan  
Titanium  
Titanio  
Titane  
Titanio



“AT”  
Atraumatische Riefung  
Atraumatic serration  
Estrías atraumáticas  
Striure atraumatique  
Zigrinatura atraumatica

**Atraumatische Pinzetten und Mikro-Pinzetten**  
**Atraumatic Forceps and Micro Forceps**  
**Pinzas atraumáticas y micro pinzas**  
**Pinces atraumatiques et micro pinces**  
**Pinze atraumatiche e micro pinze**

**A03**



**DeBakey "AT"**

1,2 mm	1,2 mm	1,2 mm
15 cm – 6" <b>06.90.15</b>	18 cm – 7 1/8" <b>06.90.18</b>	21 cm – 8 1/4" <b>06.90.21</b>
1,8 mm	1,8 mm	1,8 mm
15 cm – 6" <b>06.92.15</b>	18 cm – 7 1/8" <b>06.92.18</b>	21 cm – 8 1/4" <b>06.92.21</b>

Juwelierpinzetten  
 Jeweler's forceps  
 Pinzas para joyero/relojero  
 Pinces pour joaillier/horloger  
 Pinze per gioielliere/orologiaio



11,5 cm – 4 1/2" <b>07.60.03</b>	11,5 cm – 4 1/2" <b>07.60.04</b>	11,5 cm – 4 1/2" <b>07.60.05</b>	11,5 cm – 4 1/2" <b>07.60.07</b>
no. 3	no. 4	no. 5	no. 7

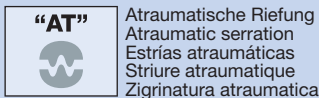

**"AT"**  
 Atraumatische Riefung  
 Atraumatic serration  
 Estrias atraumáticas  
 Striure atraumatique  
 Zigrinatura atraumatica



**Ti**  
 Titan  
 Titanium  
 Titano  
 Titane  
 Titanio

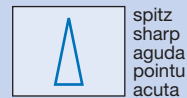

spitz  
 sharp  
 aguda  
 pointu  
 acuta



**Mikro-Pinzetten**  
**Micro Forceps**  
**Micro pinzas**  
**Micro pinces**  
**Micro pinze**

**A03**

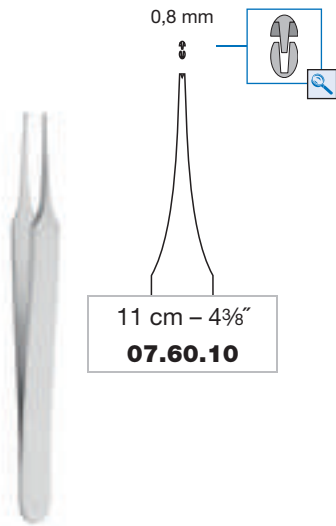

11 cm - 4<sup>3</sup>/<sub>8</sub>"  
**07.60.10**

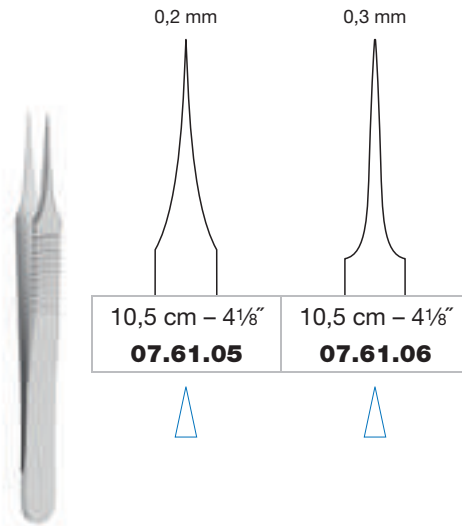

10,5 cm - 4<sup>1</sup>/<sub>8</sub>" **07.61.05**  
10,5 cm - 4<sup>1</sup>/<sub>8</sub>" **07.61.06**

**micro 2000**

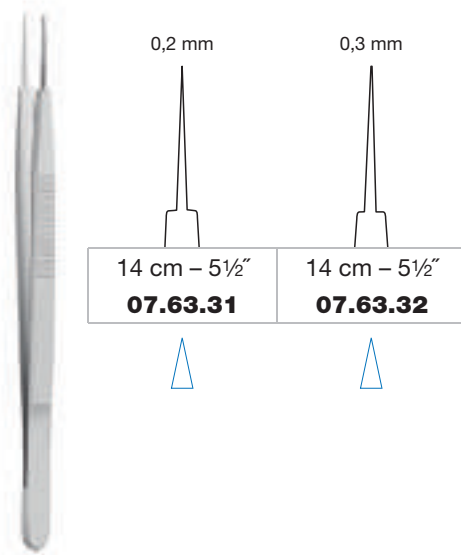

14 cm - 5<sup>1</sup>/<sub>2</sub>" **07.63.31**  
14 cm - 5<sup>1</sup>/<sub>2</sub>" **07.63.32**

**micro 2000**

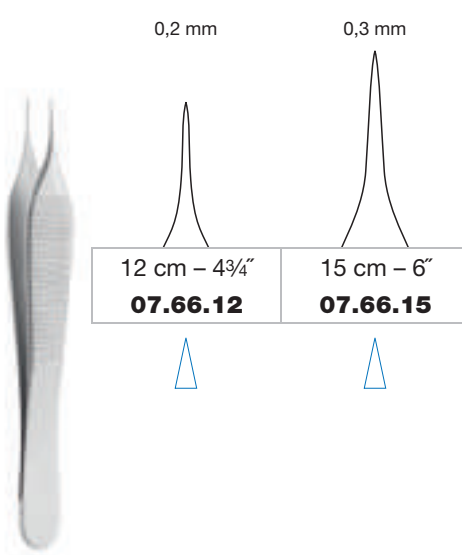

12 cm - 4<sup>3</sup>/<sub>4</sub>" **07.66.12**  
15 cm - 6" **07.66.15**

**Jacobson-Adson**



Vergrößerung  
Magnification  
Engrandecimiento  
Agrandissement  
Ingrandimento



spitz  
sharp  
aguda  
pointu  
acuta



stumpf  
blunt  
roma  
mousse  
smussa

0,2 mm	0,2 mm	0,3 mm	0,3 mm
12 cm – 4¾"	12 cm – 4¾"	12 cm – 4¾"	12 cm – 4¾"
<b>07.64.03</b>	<b>07.64.13</b>	<b>07.64.04</b>	<b>07.64.14</b>

**micro 2000**

0,2 mm	0,3 mm	0,3 mm	0,4 mm
12,5 cm – 5"	12,5 cm – 5"	13,5 cm – 5⅜"	19,5 cm – 7¾"
<b>07.61.11</b>	<b>07.61.12</b>	<b>07.61.14</b>	<b>07.72.19</b>

**micro 2000**



spitz  
sharp  
aguda  
pointu  
acuta



stumpf  
blunt  
roma  
mousse  
smussa







**Mikro-Pinzetten**  
**Micro Forceps**  
**Micro pinzas**  
**Micro pinces**  
**Micro pinze**

A03



micro 2000

0,2 mm	0,2 mm	0,3 mm	0,3 mm
15 cm - 6"	15 cm - 6"	15 cm - 6"	15 cm - 6"
<b>07.64.63</b>	<b>07.64.73</b>	<b>07.64.64</b>	<b>07.64.74</b>
			



Instrumente mit blau eloxierten Leichtmetall-Griffen für höchste Präzision und Arbeitskomfort.

Instruments with blue anodized light metal handles for maximum precision and working convenience.





Instrumentos con mangos de metal ligero anodizados en azul para la precisión y el confort de trabajo máximo.

Instruments avec manches en métal léger anodisés en bleu pour un maximum de précision et de confort à l'utilisation.

Strumenti con manici di metallo leggero anodizzati blu per una precisione massima e conforto lavorativo.



micro 2000

0,3 mm	0,3 mm	0,4 mm	0,4 mm
18 cm - 7 1/8"	18 cm - 7 1/8"	18 cm - 7 1/8"	18 cm - 7 1/8"
<b>07.64.83</b>	<b>07.64.93</b>	<b>07.64.84</b>	<b>07.64.94</b>
			



spitz  
sharp  
aguda  
pointu  
acuta



stumpf  
blunt  
roma  
mousse  
smussa



0,4 mm	0,4 mm	0,5 mm
11 cm – 4 <sup>3</sup> / <sub>8</sub> "	15 cm – 6"	18 cm – 7 <sup>1</sup> / <sub>8</sub> "
<b>07.70.11</b>	<b>07.70.15</b>	<b>07.70.18</b>

**Jacobson**

0,8 mm	1,2 mm	1,0 mm
16,5 cm – 6 <sup>1</sup> / <sub>2</sub> "	16,5 cm – 6 <sup>1</sup> / <sub>2</sub> "	19 cm – 7 <sup>1</sup> / <sub>2</sub> "
<b>07.75.30</b>	<b>07.75.31</b>	<b>07.75.32</b>

 spitz  
sharp  
aguda  
pointu  
acuta



**Mikro-Pinzetten**  
**Micro Forceps**  
**Micro pinzas**  
**Micro pinces**  
**Micro pinze**

**A03**



**Ti**

8 mm



0,4 mm

0,4 mm

0,4 mm

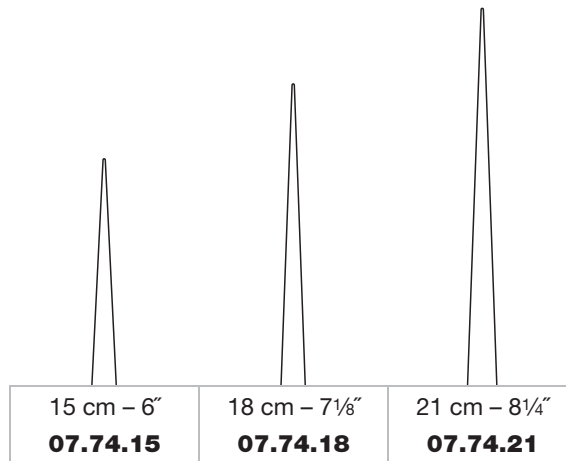

0,8 mm

0,8 mm

0,8 mm

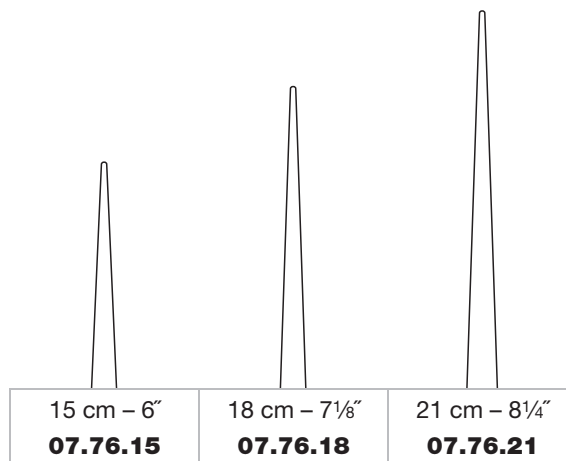

spitz  
sharp  
aguda  
pointu  
acuta



stumpf  
blunt  
roma  
mousse  
smussa



Titan  
Titanium  
Titanio  
Titane  
Titano



Rundgriff  
Round handle  
Mango redondo  
Manche rond  
Manico rotondo

**Mikro-Pinzetten**  
**Micro Forceps**  
**Micro pinzas**  
**Micro pincers**  
**Micro pinze**

**A03**



mit Gewicht  
 with weight  
 con peso  
 avec poids  
 con peso

**Dennis**



Ø 1,0 mm



18,5 cm – 7¼"  
**59.19.10**

Ø 1,0 mm



18,5 cm – 7¼"  
**59.19.11**

Ø 1,0 mm



21 cm – 8¼"  
**59.19.12**

Ø 1,0 mm



21 cm – 8¼"  
**59.19.13**



Ø 1,0 mm



18 cm – 7⅛"  
**59.19.14**

Ø 1,0 mm



21 cm – 8¼"  
**59.19.15**

Ø 1,0 mm



21 cm – 8¼"  
**59.19.16**



0,4 mm



18 cm – 7⅛"  
**59.19.17**

0,4 mm



21 cm – 8¼"  
**59.19.18**

0,4 mm



21 cm – 8¼"  
**59.19.19**



Rundgriff  
 Round handle  
 Mango redondo  
 Manche rond  
 Manico rotondo



Beschichtung mit Diamantstaub  
 Coating with diamond dust  
 Recubierto con polvo de diamante  
 Revêtement avec de poussière de diamant  
 Rivestito con polvere di diamante



Vergrößerung  
 Magnification  
 Engrandecimiento  
 Agrandissement  
 Ingrandimento



**Mikro-Pinzetten**  
**Micro Forceps**  
**Micro pinzas**  
**Micro pinces**  
**Micro pinze**

**A03**



Ø 1,0 mm

Ø 1,0 mm

Ø 1,0 mm



15 cm – 6"  
**59.45.15**

18 cm – 7 1/8"  
**59.45.18**

21 cm – 8 1/4"  
**59.45.21**

Ø 2,0 mm

Ø 2,0 mm

Ø 2,0 mm



15 cm – 6"  
**59.46.15**

18 cm – 7 1/8"  
**59.46.18**

21 cm – 8 1/4"  
**59.46.21**



Ø 1,0 mm

Ø 1,0 mm

Ø 1,0 mm



15 cm – 6"  
**59.47.15**

18 cm – 7 1/8"  
**59.47.18**

21 cm – 8 1/4"  
**59.47.21**



Ø 2,0 mm

Ø 2,0 mm

Ø 2,0 mm



15 cm – 6"  
**59.48.15**

18 cm – 7 1/8"  
**59.48.18**

21 cm – 8 1/4"  
**59.48.21**



**Ti**  
Titan  
Titanium  
Titanio  
Titane  
Titanio

  
Ringe gerieft  
Tips serrated  
Anillos estriados  
Anneaux striés  
Anelli zigrinati

  
Beschichtung mit Diamantstaub  
Coating with diamond dust  
Recubierto con polvo de diamante  
Revêtement avec de poussière de diamant  
Rivestito con polvere di diamante



mit Gewicht  
 with weight  
 con peso  
 avec poids  
 con peso



Ø 1,0 mm

Ø 1,0 mm

Ø 1,0 mm

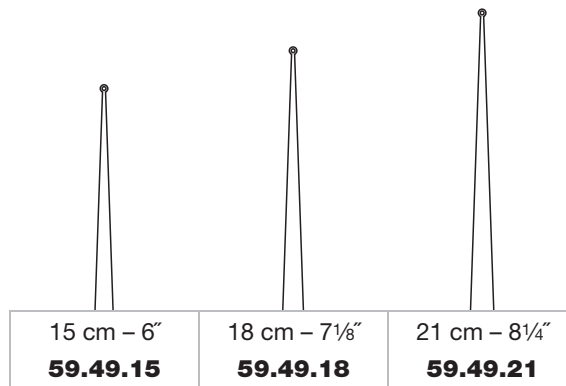

Bajonettpinzetten  
 Bayonet forceps  
 Pinzas en forma bayoneta  
 Pinces en forme baïonnette  
 Pinze a forma di baionetta

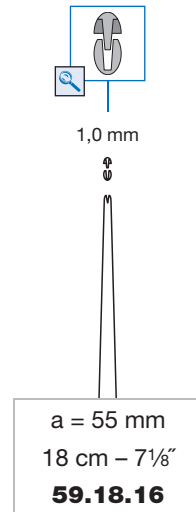
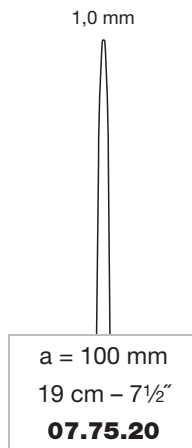

**Yasargil**



Rundgriff  
 Round handle  
 Mango redondo  
 Manche rond  
 Manico rotondo



stumpf  
 blunt  
 roma  
 mousse  
 smussa



Vergrößerung  
 Magnification  
 Engrandecimiento  
 Agrandissement  
 Ingrandimento



**Mikro-Pinzetten**  
**Micro Forceps**  
**Micro pinzas**  
**Micro pinces**  
**Micro pinze**

# A03

Bajonettpinzetten  
 Bayonet forceps  
 Pinzas en forma bayoneta  
 Pinces en forme baïonnette  
 Pinze a forma di baionetta

extrem leicht  
 extremely light  
 especialmente ligera  
 extrêmement légère  
 estremamente leggera

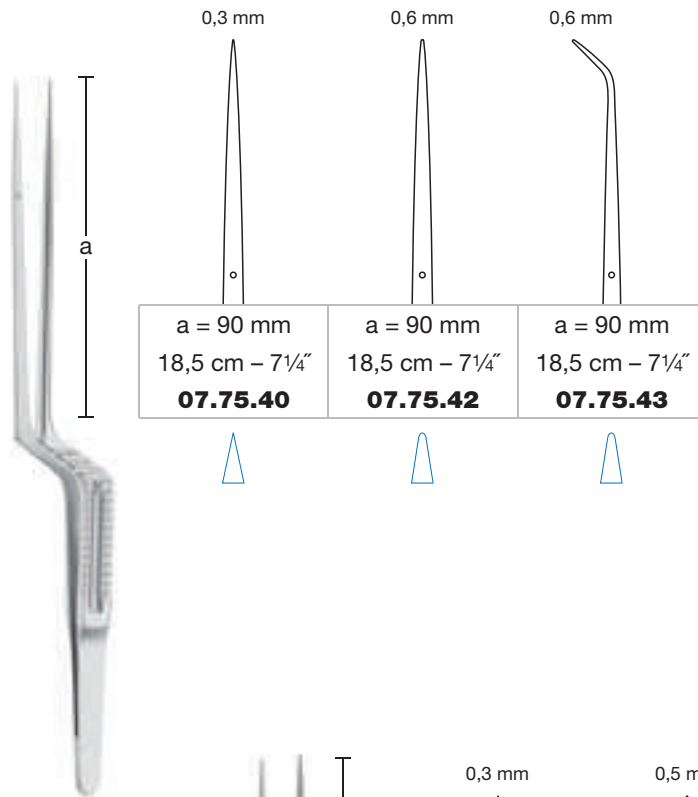

Instrumente mit blau eloxierten  
 Leichtmetall-Griffen für höchste  
 Präzision und Arbeitskomfort.

Instruments with blue anodized light  
 metal handles for maximum precision  
 and working convenience.

Instrumentos con mangos de metal  
 ligero anodizados en azul para la  
 precisión y el confort de trabajo  
 máximo.

Instruments avec manches en métal  
 léger anodisés en bleu pour un  
 maximum de précision et de confort  
 à l'utilisation.

Strumenti con manici di metallo  
 leggero anodizzati blu per una  
 precisione massima e conforto  
 lavorativo.

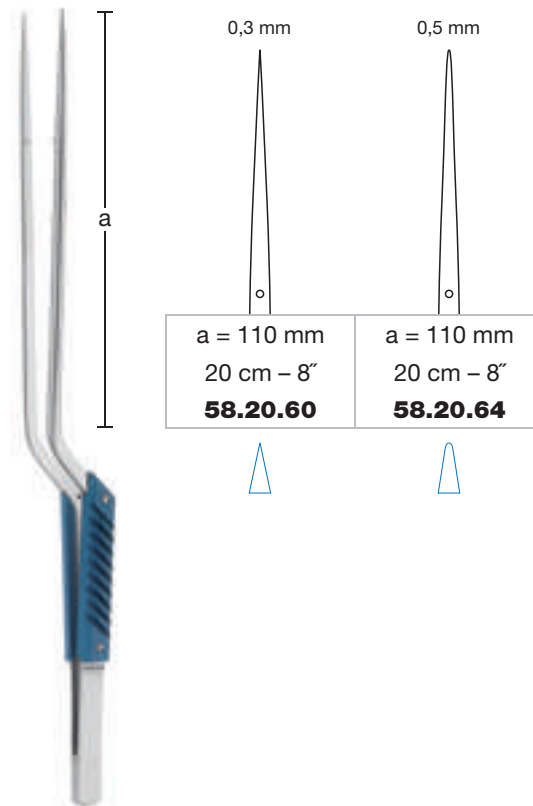

**micro 2000**



spitz  
 sharp  
 aguda  
 pointu  
 acuta



stumpf  
 blunt  
 roma  
 mousse  
 smussa

Bajonettpinzetten  
 Bayonet forceps  
 Pinzas en forma bayoneta  
 Pincers en forme baïonnette  
 Pinze a forma di baionetta



0,6 mm	0,6 mm	0,6 mm	0,6 mm
a = 55 mm 18 cm – 7 1/8" <b>59.18.10</b>	a = 75 mm 20 cm – 8" <b>59.20.10</b>	a = 95 mm 22 cm – 8 3/4" <b>59.20.16</b>	a = 105 mm 24 cm – 9 1/2" <b>59.24.10</b>
0,9 mm	0,9 mm	0,9 mm	0,9 mm
a = 55 mm 18 cm – 7 1/8" <b>59.18.14</b>	a = 75 mm 20 cm – 8" <b>59.20.14</b>	a = 95 mm 22 cm – 8 3/4" <b>59.20.18</b>	a = 105 mm 24 cm – 9 1/2" <b>59.24.14</b>



stumpf  
 blunt  
 roma  
 mousse  
 smussa



# A03

**Mikro-Pinzetten**  
**Micro Forceps**  
**Micro pinzas**  
**Micro pincers**  
**Micro pinze**



Bajonettpinzetten  
 Bayonet forceps  
 Pinzas en forma bayoneta  
 Pincers en forme baïonnette  
 Pinze a forma di baionetta



**Yasargil**

0,6 mm

0,9 mm

a

a

a = 105 mm

23 cm - 9"

**59.23.10**

a = 105 mm

23 cm - 9"

**59.23.14**



Ø 3,0 mm



**Yasargil**

a = 100 mm

22 cm - 8 3/4"

**59.44.50**



spitz  
 sharp  
 aguda  
 pointu  
 acuta



stumpf  
 blunt  
 roma  
 mousse  
 smussa



**Bajonettpinzetten**  
**Bayonet Forceps**  
**Pinzas en forma bayoneta**  
**Pinces en forme baïonnette**  
**Pinze a forma di baionetta**

**A03**

Bajonettpinzetten  
 Bayonet forceps  
 Pinzas en forma bayoneta  
 Pinces en forme baïonnette  
 Pinze a forma di baionetta



a = 80 mm 18,5 cm – 7¼"	a = 95 mm 19,5 cm – 7¾"	a = 80 mm 18,5 cm – 7¼"
<b>07.26.18</b>	<b>07.26.19</b>	<b>07.27.18</b>



**Cushing (Taylor)**



a = 95 mm 18,5 cm – 7¼"
<b>07.26.68</b>



**Cushing (Taylor) "HM"**



a = 85 mm 16 cm – 6¼"	a = 95 mm 19,5 cm – 7¾"
<b>07.30.16</b>	<b>07.30.19</b>
a = 85 mm 16 cm – 6¼"	a = 95 mm 19,5 cm – 7¾"
<b>07.31.16</b>	<b>07.31.19</b>

**Gruenwald**

**"HM"**  
 Hartmetall  
 Tungsten carbide  
 Carburo de tungsteno  
 Carbure de tungstène  
 Carburo di tungsteno

mit Dissektorende  
 with dissector end  
 con extremo sirviendo de legra  
 avec extrémité dissecteur  
 con la parte finale a forma di dissettor



**Fasspinzetten**  
**Grasping Forceps**  
**Pinzas para agarrar**  
**Pinces pour saisir**  
**Pinze da presa**

**A03**



**Hunt**

Ø 5 mm



20 cm – 8"  
**58.44.05**



**Yasargil**

a

Ø 3 mm



a = 100 mm  
22 cm – 8¾"  
**59.44.03**

Ø 3 mm



a = 100 mm  
22 cm – 8¾"  
**59.44.13**

Ø 3 mm



a = 100 mm  
22 cm – 8¾"  
**59.44.73**

Ø 5 mm



a = 100 mm  
22 cm – 8¾"  
**59.44.05**

Ø 5 mm



a = 100 mm  
22 cm – 8¾"  
**59.44.15**

Ø 5 mm



a = 100 mm  
22 cm – 8¾"  
**59.44.75**

**Fasspinzetten und Tumorfasszangen**  
**Grasping Forceps and Tumor Grasping Forceps**  
**Pinzas para agarrar y pinzas para agarrar tumores**  
**Pinces pour saisir et pinces à saisir pour tumeurs**  
**Pinze da presa e pinze per afferrare tumori**

**A03**



**Yasargil**

Ø 3 mm



a = 40 mm  
 16,5 cm – 6½”  
**59.44.43**

Ø 5 mm



a = 40 mm  
 16,5 cm – 6½”  
**59.44.45**

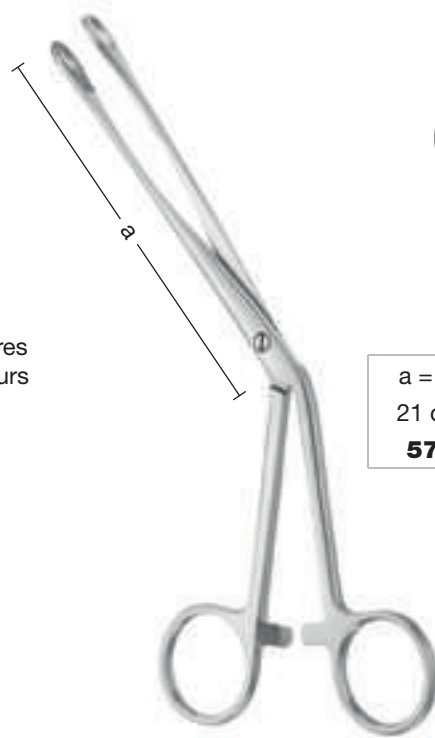

**Toennis**

Tumorfasszangen  
 Tumor grasping forceps  
 Pinzas para agarrar tumores  
 Pinces à saisir pour tumeurs  
 Pinze per afferrare tumori

7 mm



a = 100 mm  
 21 cm – 8¼”  
**57.29.07**

10 mm

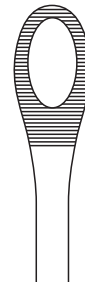

a = 105 mm  
 21 cm – 8¼”  
**57.29.10**

12 mm

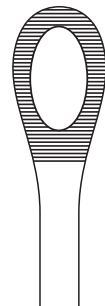

a = 110 mm  
 21 cm – 8¼”  
**57.29.12**



**Nahtpinzetten**  
**Suturing Forceps**  
**Pinzas para sutura**  
**Pinces à suture**  
**Pinze per sutura**

**A03**

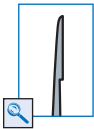

0,3 mm

10,5 cm - 4 1/8"  
**13.70.42**

**micro 2000**

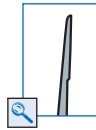

8 mm



0,3 mm



12 cm - 4 3/4"  
**13.71.50**



0,3 mm



15 cm - 6"  
**13.71.60**



0,3 mm



18 cm - 7 1/8"  
**13.71.70**

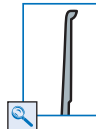

8 mm



0,3 mm



12 cm - 4 3/4"  
**13.71.52**

0,3 mm



15 cm - 6"  
**13.71.62**

0,3 mm



18 cm - 7 1/8"  
**13.71.72**



Vergrößerung  
Magnification  
Engrandecimiento  
Agrandissement  
Ingrandimento



Rundgriff  
Round handle  
Mango redondo  
Manche rond  
Manico rotondo



spitz  
sharp  
aguda  
pointu  
acuta

**Nahtpinzetten**  
**Suturing Forceps**  
**Pinzas para sutura**  
**Pinces à suture**  
**Pinze per sutura**

**A03**

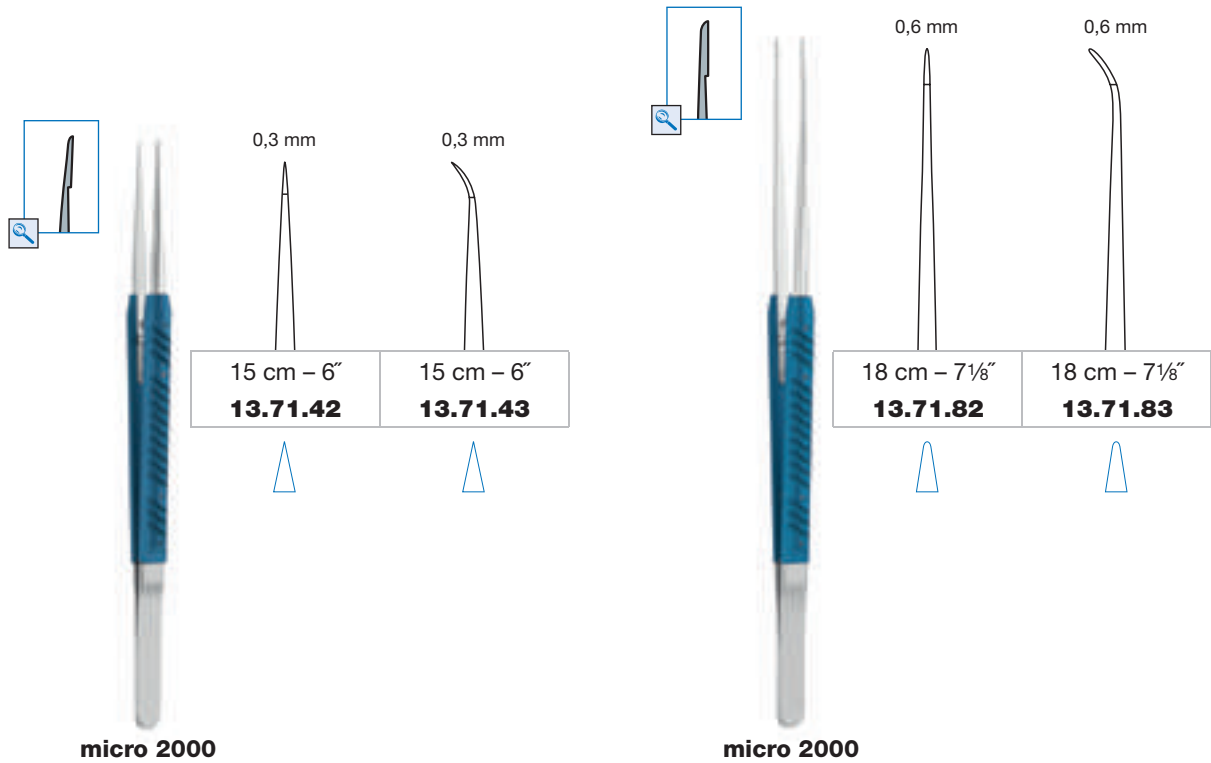

Instrumente mit blau eloxierten Leichtmetall-Griffen für höchste Präzision und Arbeitskomfort.

Instruments with blue anodized light metal handles for maximum precision and working convenience.

Instrumentos con mangos de metal ligero anodizados en azul para la precisión y el confort de trabajo máximo.

Instruments avec manches en métal léger anodisés en bleu pour un maximum de précision et de confort à l'utilisation.

Strumenti con manici di metallo leggero anodizzati blu per una precisione massima e conforto lavorativo.



spitz  
sharp  
aguda  
pointu  
acuta



stumpf  
blunt  
roma  
mousse  
smussa



Vergrößerung  
Magnification  
Engrandecimiento  
Agrandissement  
Ingrandimento



**Nahtpinzetten**  
**Suturing Forceps**  
**Pinzas para sutura**  
**Pinces à suture**  
**Pinze per sutura**

**A03**

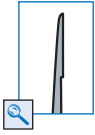

0,5 mm

0,8 mm

14 cm – 5½"

14 cm – 5½"

**13.70.72**

**13.70.74**



**micro 2000**

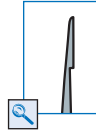

0,3 mm

0,3 mm

12 cm – 4¾"

12 cm – 4¾"

**13.71.22**

**13.71.23**



**micro 2000**

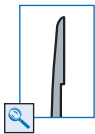

0,6 mm

23 cm – 9"

**13.71.84**



8 mm



0,8 mm

18 cm – 7½"

**13.71.86**



**Austin**



Rundgriff  
Round handle  
Mango redondo  
Manche rond  
Manico rotondo



spitz  
sharp  
aguda  
pointu  
acuta



stumpf  
blunt  
roma  
mousse  
smussa



Vergrößerung  
Magnification  
Engrandecimiento  
Agrandissement  
Ingrandimento

Kein Anhaften von Biogewebe ◀  
 Schnelle Wärme- und Stromableitung ◀  
 Einfache Reinigung ◀

No adhesion of biological tissue ◀  
 Quick discharge of heat and current ◀  
 Easy to clean ◀

Ninguna adherencia del tejido ◀  
 Derivación rápida del calor y corriente ◀  
 Mantenimiento fácil ◀

Les tissus ne collent pas à la pince ◀  
 Conductivité rapide et sûre de la chaleur et de l'électricité ◀  
 Entretien facile ◀

Nessuna adesione di tessuti ◀  
 Derivazione veloce di calore e corrente ◀  
 Pulizia facile ◀

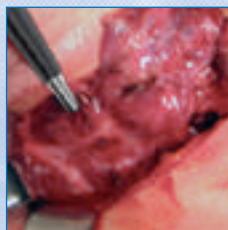
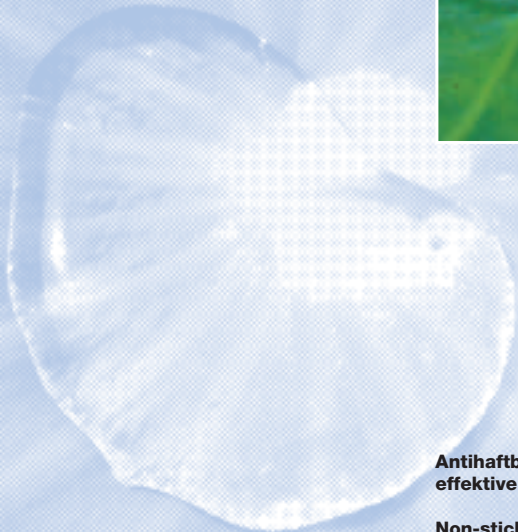

**Antihftbeschichtung sorgt für eine effektive Koagulation**

**Non-stick coating assures an effective coagulation**

**El recubrimiento no adherente permite una coagulación eficaz**

**Grâce à ses pointes anti-adhésives, la pince bipolaire permet une meilleure coagulation**

**Il rivestimento antiaderente permette una coagulazione effettiva**





A04

**Bipolare Antihaft-Pinzetten**  
**Bipolar Non-stick Forceps**  
**Pinzas bipolares no adherentes**  
**Pinces bipolaires anti-adhésives**  
**Pinze bipolari antiaderenti**

**MAGIC**  
non-stick



	0,6 mm	1,0 mm	
	15 cm – 6"	15 cm – 6"	
	<b>88.07.02</b>	<b>88.07.03</b>	
	0,6 mm	1,0 mm	
18 cm – 7 1/8"	18 cm – 7 1/8"		
<b>88.07.07</b>	<b>88.07.08</b>		
0,6 mm	1,0 mm		
20 cm – 8"	20 cm – 8"		
<b>88.07.12</b>	<b>88.07.13</b>		

	1,3 mm	
	20 cm – 8"	
	<b>88.07.14</b>	
	2,0 mm	
20 cm – 8"		
<b>88.07.15</b>		

Juwelierpinzetten  
Jeweler's forceps  
Pinzas para joyero/relojero  
Pinces pour joaillier/horloger  
Pinze per gioielliere/orologiaio

	0,25 mm	0,6 mm	1,0 mm
	11 cm – 4 3/8"	11 cm – 4 3/8"	11 cm – 4 3/8"
	<b>88.07.81</b>	<b>88.07.82</b>	<b>88.07.83</b>

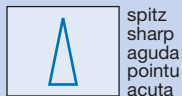

spitz  
sharp  
aguda  
pointu  
acuta



stumpf  
blunt  
roma  
mousse  
smussa



**MAGIC**  
non-stick

**Bipolare Antihaft-Pinzetten**  
**Bipolar Non-stick Forceps**  
**Pinzas bipolares no adherentes**  
**Pinces bipolaires anti-adhésives**  
**Pinze bipolari antiaderenti**

**A04**

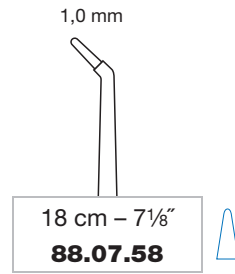
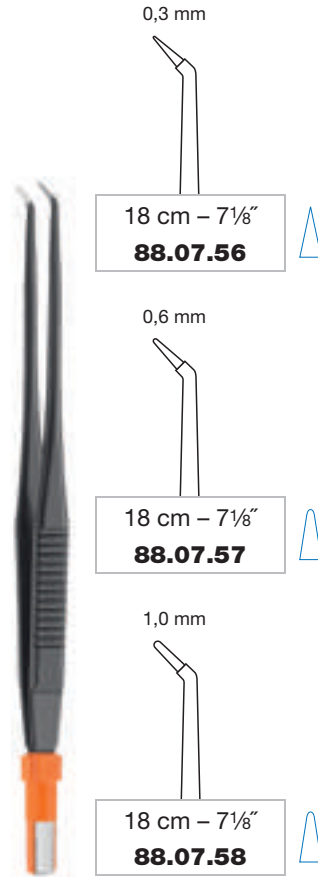
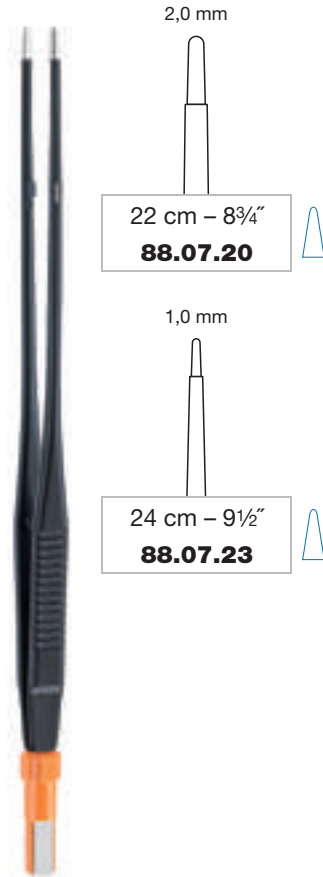

Juwelierpinzetten  
Jeweler's forceps  
Pinzas para joyero/relojero  
Pinces pour joaillier/horloger  
Pinze per gioielliere/orologiaio

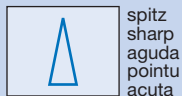
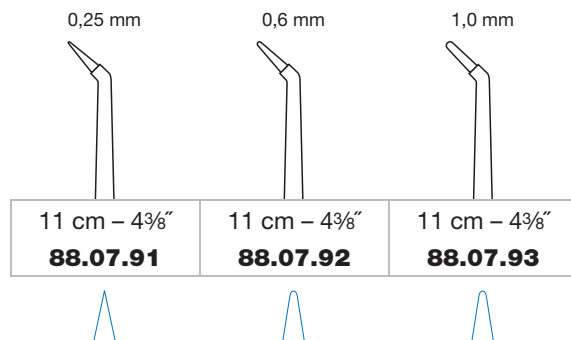

spitz  
sharp  
aguda  
pointu  
acuta



stumpf  
blunt  
roma  
mousse  
smussa

**A04**

**Bipolare Antihaft-Pinzetten**  
**Bipolar Non-stick Forceps**  
**Pinzas bipolares no adherentes**  
**Pinces bipolaires anti-adhésives**  
**Pinze bipolari antiaderenti**

**MAGIC**  
non-stick

Bajonettpinzetten  
 Bayonet forceps  
 Pinzas en forma bayoneta  
 Pinces en forme baïonnette  
 Pinze a forma di baionetta



a

0,3 mm	0,6 mm	1,0 mm	1,3 mm	2,0 mm
a = 100 mm 20 cm – 8"	a = 100 mm 20 cm – 8"	a = 100 mm 20 cm – 8"	a = 100 mm 20 cm – 8"	a = 100 mm 20 cm – 8"
<b>88.08.01</b>	<b>88.08.02</b>	<b>88.08.03</b>	<b>88.08.04</b>	<b>88.08.05</b>
0,3 mm	0,6 mm	1,0 mm	1,3 mm	2,0 mm
a = 130 mm 22 cm – 8¾"	a = 130 mm 22 cm – 8¾"	a = 130 mm 22 cm – 8¾"	a = 130 mm 22 cm – 8¾"	a = 130 mm 22 cm – 8¾"
<b>88.08.06</b>	<b>88.08.07</b>	<b>88.08.08</b>	<b>88.08.09</b>	<b>88.08.10</b>
0,3 mm	0,6 mm	1,0 mm	1,3 mm	2,0 mm
a = 150 mm 24 cm – 9½"	a = 150 mm 24 cm – 9½"	a = 150 mm 24 cm – 9½"	a = 150 mm 24 cm – 9½"	a = 150 mm 24 cm – 9½"
<b>88.08.11</b>	<b>88.08.12</b>	<b>88.08.13</b>	<b>88.08.14</b>	<b>88.08.15</b>



spitz  
sharp  
aguda  
pointu  
acuta



stumpf  
blunt  
roma  
mousse  
smussa



# MAGIC non-stick



**Bipolare Antihaft-Pinzetten**  
**Bipolar Non-stick Forceps**  
**Pinzas bipolares no adherentes**  
**Pinces bipolaires anti-adhésives**  
**Pinze bipolari antiaderenti**



**A04**



Bajonettpinzetten  
 Bayonet forceps  
 Pinzas en forma bayoneta  
 Pinces en forme baïonnette  
 Pinze a forma di baionetta



0,3 mm 	0,6 mm 	1,0 mm 
a = 80 mm 18 cm – 7 1/8"	a = 80 mm 18 cm – 7 1/8"	a = 80 mm 18 cm – 7 1/8"
<b>88.08.91</b>	<b>88.08.92</b>	<b>88.08.93</b>

0,3 mm 	0,6 mm 	1,0 mm 
a = 100 mm 20 cm – 8"	a = 100 mm 20 cm – 8"	a = 100 mm 20 cm – 8"
<b>88.08.71</b>	<b>88.08.72</b>	<b>88.08.73</b>

0,3 mm 	0,6 mm 
a = 120 mm 22 cm – 8 3/4"	a = 120 mm 22 cm – 8 3/4"
<b>88.08.76</b>	<b>88.08.77</b>

0,3 mm 	0,6 mm 
a = 140 mm 24 cm – 9 1/2"	a = 140 mm 24 cm – 9 1/2"
<b>88.08.81</b>	<b>88.08.82</b>

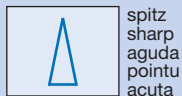

spitz  
sharp  
aguda  
pointu  
acuta



stumpf  
blunt  
roma  
mousse  
smussa

**A04**

**Bipolare Pinzetten**  
**Bipolar Forceps**  
**Pinzas bipolares**  
**Pinces bipolaires**  
**Pinze bipolari**



0,15 mm	0,6 mm	0,15 mm	0,6 mm
16,5 cm – 6½"	16,5 cm – 6½"	16,5 cm – 6½"	16,5 cm – 6½"
<b>88.17.05</b>	<b>88.17.06</b>	<b>88.17.07</b>	<b>88.17.08</b>
0,15 mm	0,6 mm	0,15 mm	0,6 mm
20 cm – 8"	20 cm – 8"	20 cm – 8"	20 cm – 8"
<b>88.20.05</b>	<b>88.20.06</b>	<b>88.20.07</b>	<b>88.20.08</b>

Bajonettpinzetten  
 Bayonet forceps  
 Pinzas en forma bayoneta  
 Pinces en forme baionnette  
 Pinze a forma di baionetta



1,0 mm	1,0 mm
a = 90 mm	a = 90 mm
19 cm – 7½"	19 cm – 7½"
<b>88.70.38</b>	<b>88.70.39</b>



spitz  
 sharp  
 aguda  
 pointu  
 acuta



stumpf  
 blunt  
 roma  
 mousse  
 smussa

**Bipolare Pinzetten**  
**Bipolar Forceps**  
**Pinzas bipolares**  
**Pinces bipolaires**  
**Pinze bipolari**

**A04**

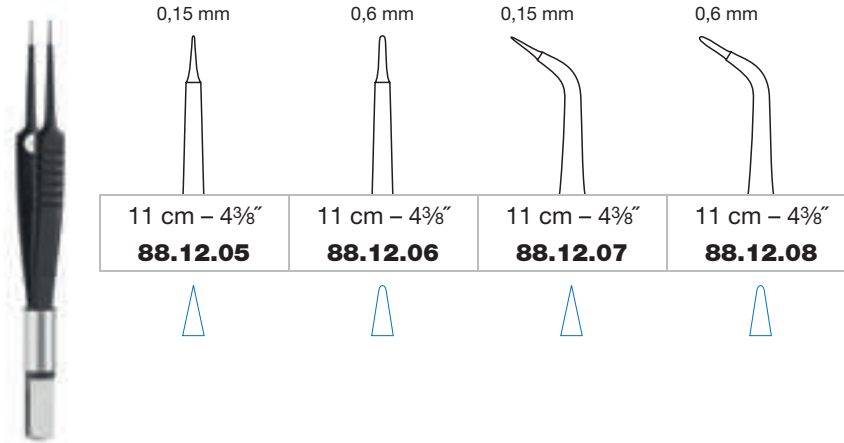

Bajonettpinzetten  
 Bayonet forceps  
 Pinzas en forma bayoneta  
 Pinces en forme baïonnette  
 Pinze a forma di baionetta

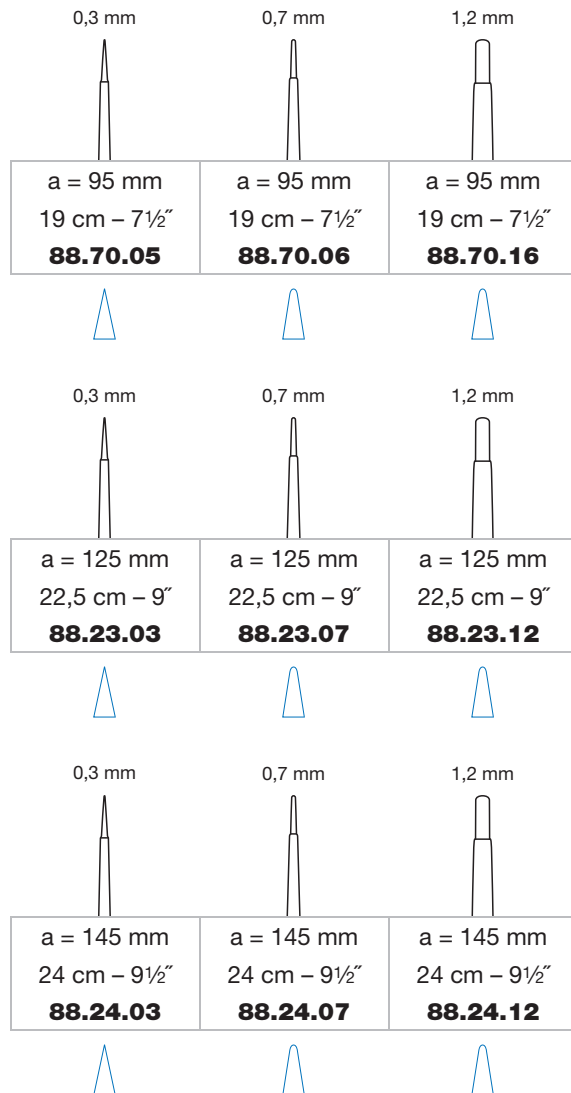

spitz  
 sharp  
 aguda  
 pointu  
 acuta



stumpf  
 blunt  
 roma  
 mousse  
 smussa

**A04**

**Bipolare Anschlusskabel und Halteklammer**  
**Bipolar Connecting Cables and Bracket**  
**Cables de conexión bipolar y dispositivo**  
**Câbles connecteurs bipolaires et dispositif**  
**Cavi di connessione bipolari e dispositivo di tenuta**

Stecker für Instrumente (siehe Seite 58-63)  
 Connector for instruments (see page 58-63)  
 Enchufe para instrumentos (véase página 58-63)  
 Fiche pour instruments (voir page 58-63)  
 Attacco per strumenti (vedi pagina 58-63)

Stecker für Geräte von:  
 Connector for generator of:  
 Enchufe para equipos de:  
 Fiche pour appareils de:  
 Attacco per apparecchi:

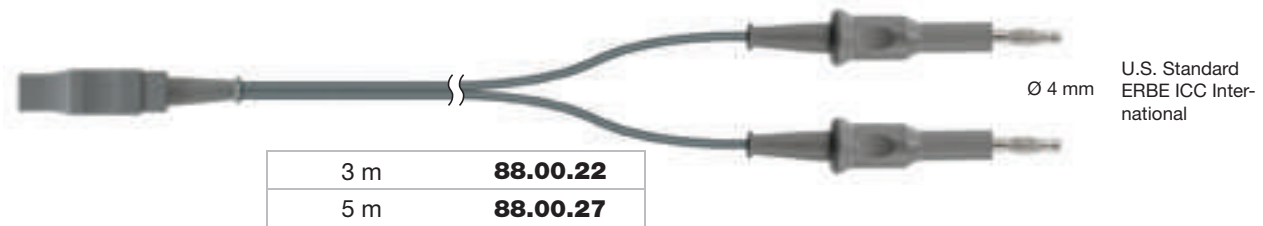
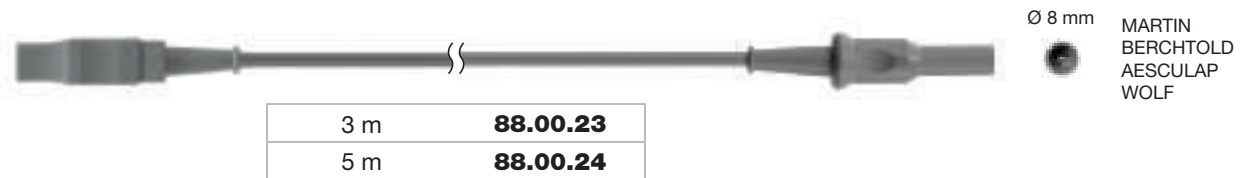
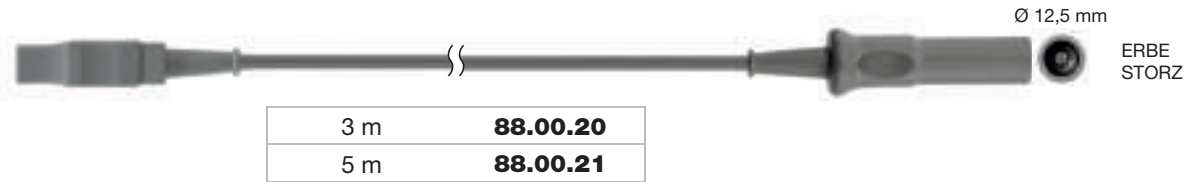

**Halteklammer für ein Hochfrequenzkabel mit Knickschutz**  
**Bracket for one high frequency cable with bend protection**  
**Dispositivo para un cable de alta frecuencia con protección contra pliegues de cables**  
**Dispositif pour un câble à haute fréquence avec protection contre plis de câble**  
**Dispositivo di tenuta per un cavo ad alta frequenza con protezione antipiega**

- ▶ Passend für Siebkörbe ab ½-Container
- ▶ Sicherheitsverschluss dient auch als Haltegriff
- ▶ Verwendbar für alle Hochfrequenzkabel
- ▶ Suitable for wire baskets starting from ½ container
- ▶ Safety lock serves as handle
- ▶ Suitable for all high frequency cables
- ▶ Aptos para bandejas a partir de ½ contenedor
- ▶ Cierre de seguridad sirve también de mango
- ▶ Utilizable para todos cables de alta frecuencia
- ▶ Approprié pour paniers à partir de ½ container
- ▶ Fermoir de sécurité utilisable comme manche
- ▶ Approprié pour tous types de câbles à haute fréquence
- ▶ Adatto per cestelli da ½ contenitore
- ▶ Chiusura di sicurezza utilizzabile come manico
- ▶ Adatto a tutti i cavi ad alta frequenza



22,5 cm - 9" **88.00.40**



**Nadelhalter**  
**Needle Holders**  
**Porta-agujas**  
**Porte-aiguilles**  
**Portaghi**

**A05**



A05

## “HM”

Nadelhalter mit Hartmetalleinlagen  
 Needle holders with tungsten carbide inserts  
 Porta-agujas con bocas revestidas con plaquitas de carburo de tungsteno  
 Porte-aiguilles avec mors en carbure de tungstène  
 Portaghi con placchette di carburo di tungsteno

**N 0,5 mm**

normal  
 regular  
 normal  
 normale  
 normale

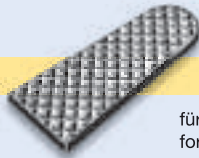

für Nadeln und Nahtmaterial bis Stärke 4-0  
 for needles and sutures up to size 4-0  
 para agujas y material de sutura hasta el espesor de 4-0  
 pour aiguilles et matériel à suture jusqu'à une épaisseur de 4-0  
 per aghi e materiale per sutura fino ad uno spessore di 4-0

**F 0,4 mm**

fein  
 fine  
 fine  
 fine  
 fine

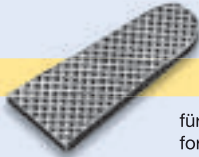

für feine Nadeln und Nahtmaterial in der Stärke 5-0 und 6-0  
 for delicate needles and sutures sizes 5-0 and 6-0  
 para agujas finas y material de sutura para espesores 5-0 y 6-0  
 pour aiguilles fines et matériel à suture d'une épaisseur de 5-0 et 6-0  
 per aghi fini e materiale per sutura fino ad uno spessore di 5-0 e 6-0

**EF 0,3 mm**

extra-fein  
 extra-fine  
 extra-fino  
 extra-fine  
 extra-fine

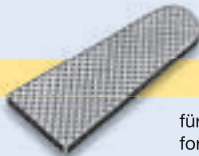

für Mikro-Nadeln und Nahtmaterial bis Stärke 10-0  
 for micro-needles and sutures up to size 10-0  
 para micro-agujas y material de sutura hasta el espesor de 10-0  
 pour micro-aiguilles et matériel à suture jusqu'à une épaisseur de 10-0  
 per aghi micro e materiale per sutura fino ad uno spessore di 10-0

glatt  
 smooth  
 liso  
 lisse  
 liscia

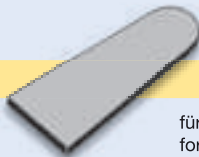

für feine Nadeln und Nahtmaterial in der Stärke 7-0 bis 10-0  
 for delicate needles and sutures from sizes 7-0 to 10-0  
 para agujas finas y material de sutura para espesores 7-0 y 10-0  
 pour aiguilles fines et matériel à suture d'une épaisseur de 7-0 à 10-0  
 per aghi fini e materiale per sutura fino ad uno spessore di 7-0 fino a 10-0





12,5 cm – 5"  
**10.08.62**

**Neivert "HM"**

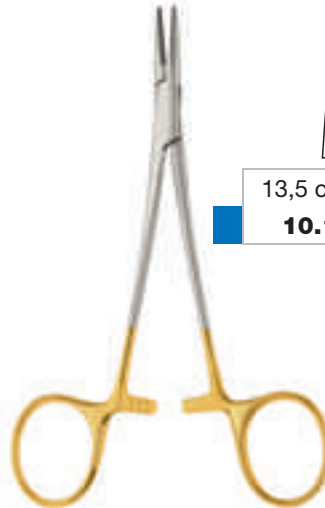

13,5 cm – 5<sup>3</sup>/<sub>8</sub>"  
**10.10.63**

**Halsey "HM"**



**N** 14 cm – 5<sup>1</sup>/<sub>2</sub>"  
**10.14.64**

**Baumgartner "HM"**



**■**  
 7-0 to 10-0  
 glatt  
 smooth  
 liso  
 lisse  
 liscia

**N**  
 4-0  
 normal  
 regular  
 normal  
 normale  
 normale

**"HM"**  
 Hartmetall  
 Tungsten carbide  
 Carburo de tungsteno  
 Carbure de tungstène  
 Carburo di tungsteno



**Nadelhalter  
Needle Holders  
Porta-agujas  
Porte-aiguilles  
Portaghi**

**A05**



**Mayo-Hegar "HM"**

**N**

16 cm – 6¼"  
**10.18.65**

18 cm – 7⅛"  
**10.18.68**

20 cm – 8"  
**10.18.70**

23 cm – 9"  
**10.18.73**

**N**

24 cm – 9½"  
**10.18.74**

26 cm – 10¼"  
**10.18.76**

30 cm – 11¾"  
**10.18.80**

**Ti**



**Mayo-Hegar "HM"**

**N**

16 cm – 6¼"  
**10.18.85**

18 cm – 7⅛"  
**10.18.88**

20 cm – 8"  
**10.18.90**

23 cm – 9"  
**10.18.93**

**"HM"**

Hartmetall  
Tungsten carbide  
Carburo de tungsteno  
Carbure de tungstène  
Carburo di tungsteno

**Ti**

Titan  
Titanium  
Titanio  
Titane  
Titano

**N**

4-0

normal  
regular  
normal  
normale  
normale



15 cm – 6"  
**10.20.14**

**Baby-Crile-Wood**



15 cm – 6" **10.20.15**      18 cm – 7 1/8" **10.20.18**

20 cm – 8" **10.20.20**      23 cm – 9" **10.20.23**

**Crile-Wood**



**Crile-Wood "HM"**  
**(DeBakey "HM")**

**F** 15 cm – 6" **10.20.65**      18 cm – 7 1/8" **10.20.68**      20 cm – 8" **10.20.70**      23 cm – 9" **10.20.73**

**F** 25 cm – 10" **10.20.75**      26 cm – 10 1/4" **10.20.76**      30 cm – 11 3/4" **10.20.80**

**"HM"**  
 Hartmetall  
 Tungsten carbide  
 Carburo de tungsteno  
 Carbure de tungstène  
 Carburo di tungsteno

**F**  
 fein  
 fine  
 fino  
 fine  
 fine



**Nadelhalter**  
**Needle Holders**  
**Porta-agujas**  
**Porte-aiguilles**  
**Portaghi**

**A05**

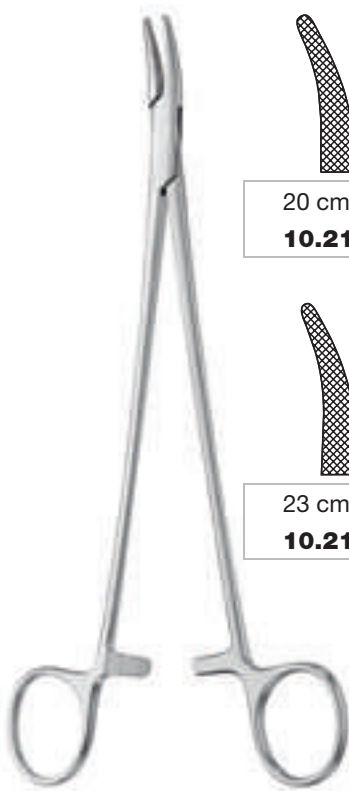

**Julian**

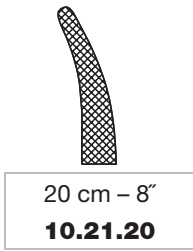

20 cm – 8"  
**10.21.20**

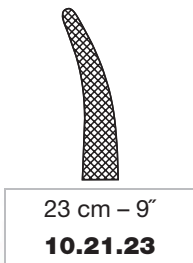

23 cm – 9"  
**10.21.23**

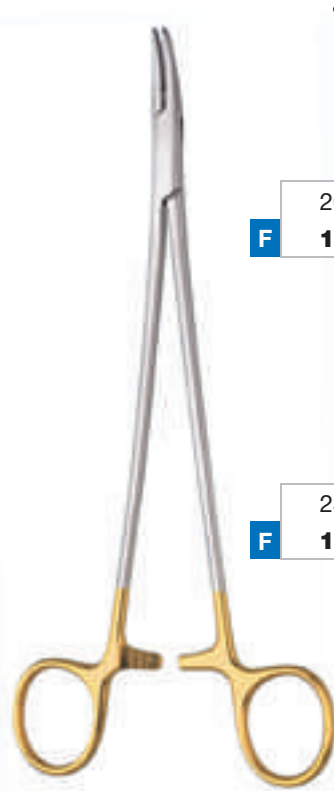

**Julian "HM"**

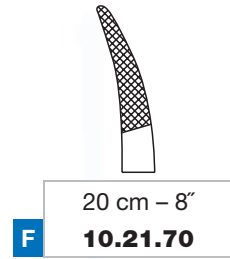

**F** 20 cm – 8"  
**10.21.70**

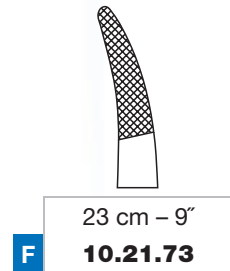

**F** 23 cm – 9"  
**10.21.73**



**Baby-Crile-Wood "HM"**

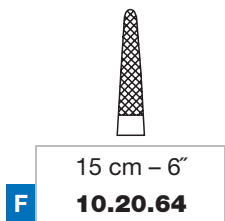

**F** 15 cm – 6"  
**10.20.64**



**Mini-Ryder "HM"**

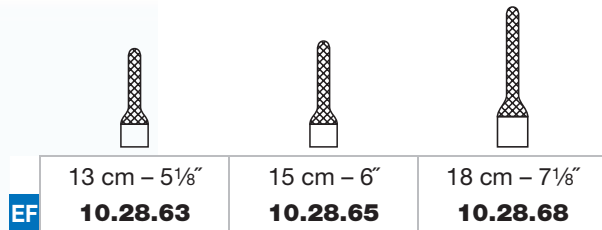

**EF** 13 cm – 5 1/8"  
**10.28.63**

**15 cm – 6"**  
**10.28.65**

**18 cm – 7 1/8"**  
**10.28.68**

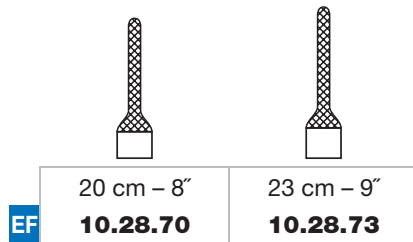

**EF** 20 cm – 8"  
**10.28.70**

**23 cm – 9"**  
**10.28.73**

**F**  
5-0 to 6-0  
fein  
fine  
fino  
fine  
fine

**EF**  
10-0  
extra-fein  
extra-fine  
extra-fino  
extra-fine  
extra-fine

**"HM"**  
Hartmetall  
Tungsten carbide  
Carburo de tungsteno  
Carbure de tungstène  
Carburo di tungsteno

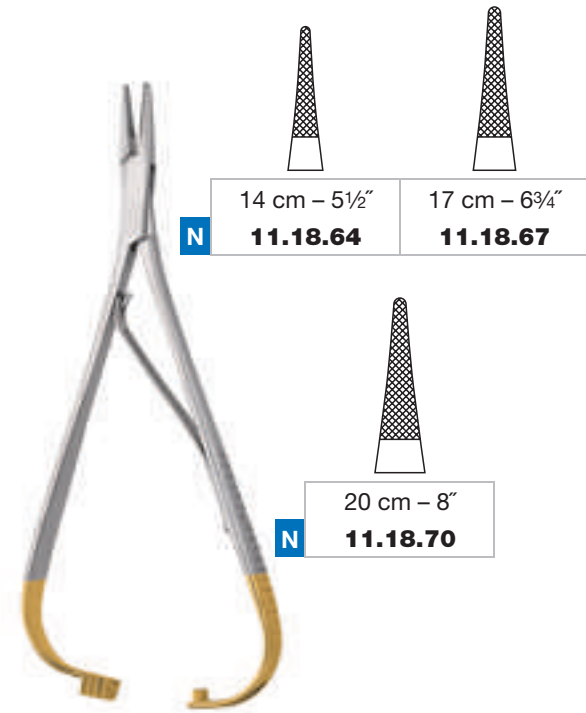

<b>N</b>	14 cm – 5½"	17 cm – 6¾"
	<b>11.18.64</b>	<b>11.18.67</b>

<b>N</b>	20 cm – 8"
	<b>11.18.70</b>

**Mathieu-Kocher "HM"**

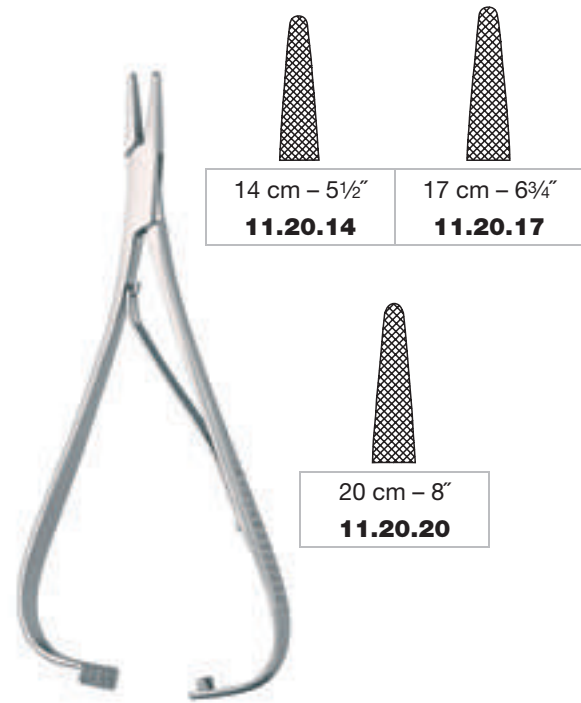

14 cm – 5½"	17 cm – 6¾"
<b>11.20.14</b>	<b>11.20.17</b>

20 cm – 8"
<b>11.20.20</b>

**Mathieu**

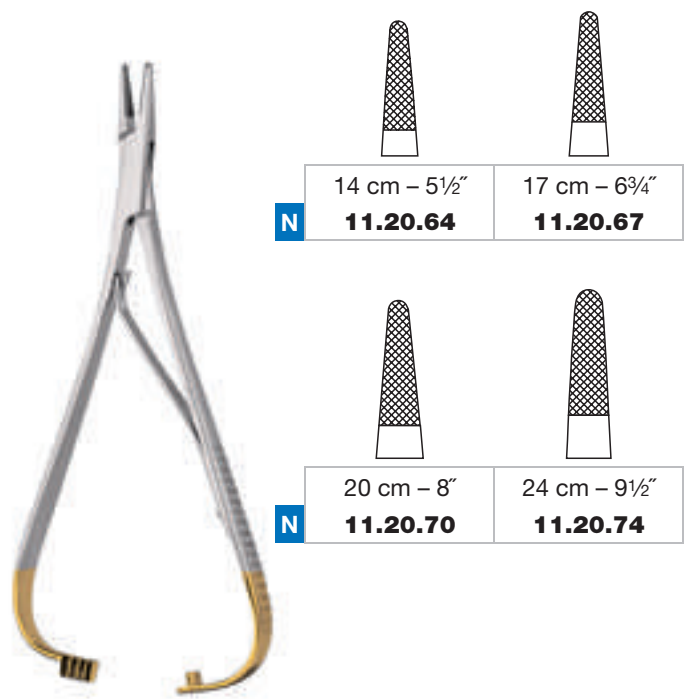

<b>N</b>	14 cm – 5½"	17 cm – 6¾"
	<b>11.20.64</b>	<b>11.20.67</b>

<b>N</b>	20 cm – 8"	24 cm – 9½"
	<b>11.20.70</b>	<b>11.20.74</b>

**Mathieu "HM"**

**"HM"**  
 Hartmetall  
 Tungsten carbide  
 Carburo de tungsteno  
 Carbure de tungstène  
 Carbuoro di tungsteno

**N**  
 4-0  
 normal  
 regular  
 normal  
 normale  
 normale

**A05**

**Nadelhalter und Mikro-Nadelhalter**  
**Needle Holders and Micro Needle Holders**  
**Porta-agujas y micro porta-agujas**  
**Porte-aiguilles et micro porte-aiguilles**  
**Portaghi e micro portaghi**



<b>N</b>	16 cm – 6¼"	18 cm – 7½"
	<b>11.34.66</b>	<b>11.34.68</b>

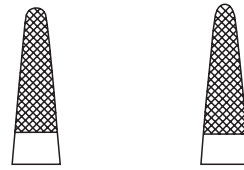

<b>N</b>	16 cm – 6¼"	18 cm – 7½"
	<b>11.36.66</b>	<b>11.36.68</b>

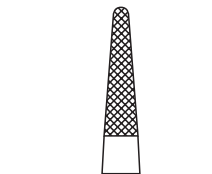

<b>N</b>	20 cm – 8"
	<b>11.34.70</b>



<b>N</b>	20 cm – 8"
	<b>11.36.70</b>

**Toennis "HM"****Langenbeck "HM"**

Mikro-Nadelhalter  
 Micro needle holders  
 Micro porta-agujas  
 Micro porte-aiguilles  
 Micro portaghi



	13 cm – 8½"
	<b>11.62.63</b>

**Castroviejo "HM"**

	14 cm – 5½"	17 cm – 6¾"
	<b>11.62.14</b>	<b>11.62.17</b>



	14 cm – 5½"	17 cm – 6¾"
	<b>11.62.15</b>	<b>11.62.18</b>

**Castroviejo**

	glatt smooth liso liscia
7-0 to 10-0	

<b>N</b>	normal regular normal normale normale
4-0	

<b>"HM"</b>	Hartmetall Tungsten carbide Carburo de tungsteno Carbure de tungstène Carburo di tungsteno
-------------	--

	mit Sperre with catch con cremallera avec crémaillère con cremagliera
--	---



**Castroviejo-micro**



14,5 cm – 5¾"  
**11.70.22**



14,5 cm – 5¾"  
**11.70.23**



14,5 cm – 5¾"  
**11.70.24**



14,5 cm – 5¾"  
**11.70.25**



11,5 cm – 4½"  
**11.74.13**



14 cm – 5½"  
**11.74.23**



11,5 cm – 4½"  
**11.74.15**



14 cm – 5½"  
**11.74.25**



**Barraquer**



14 cm – 5½"  
**11.62.64**



17 cm – 6¾"  
**11.62.67**



14 cm – 5½"  
**11.62.84**



17 cm – 6¾"  
**11.62.87**



**Castroviejo "HM"**

**"HM"**

Hartmetall  
 Tungsten carbide  
 Carburo de tungsteno  
 Carbone de tungstène  
 Carburo di tungsteno

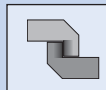

mit Sperre  
 with catch  
 con cremallera  
 avec crémaillère  
 con cremagliera

**EF**  
 10-0

extra-fein  
 extra-fine  
 extra-fino  
 extra-fine  
 extra-fine

**7-0 to 10-0**

glatt  
 smooth  
 liso  
 lisse  
 liscia



# A05

**Mikro-Nadelhalter**  
**Micro Needle Holders**  
**Micro porta-agujas**  
**Micro porte-aiguilles**  
**Micro portaghi**



**Jacobson**



18,5 cm – 7¼"  
**11.82.18**



21 cm – 8¼"  
**11.82.21**



18,5 cm – 7¼"  
**11.80.68**



21 cm – 8¼"  
**11.80.71**



18,5 cm – 7¼"  
**11.82.68**



21 cm – 8¼"  
**11.82.71**



**Jacobson "HM"**



16 cm – 6¼"  
**12.15.50**



16 cm – 6¼"  
**12.15.51**



18 cm – 7⅛"  
**11.84.68**



18 cm – 7⅛"  
**11.85.68**



18 cm – 7⅛"  
**11.86.68**



18 cm – 7⅛"  
**11.87.68**



**Yasargil**



**Jacobson "HM"**

 glatt  
smooth  
liso  
liscia

 fein  
fine  
fino  
fine

**"HM"**  
Hartmetall  
Tungsten carbide  
Carburo de tungsteno  
Carbure de tungstène  
Carburo di tungsteno

 mit Sperre  
with catch  
con cremallera  
avec crémaillère  
con cremagliera



**Mikro-Nadelhalter**  
**Micro Needle Holders**  
**Micro porta-agujas**  
**Micro porte-aiguilles**  
**Micro portaghi**

**A05**

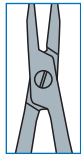

0,4 mm



0,4 mm



0,5 mm



0,5 mm



13 cm – 5 1/8"	<b>12.12.54</b>	<b>12.12.55</b>		<b>12.12.59</b>
15 cm – 6"	<b>12.15.76</b>	<b>12.15.77</b>		
18 cm – 7 1/8"	<b>12.18.76</b>	<b>12.18.77</b>	<b>12.18.80</b>	<b>12.18.81</b>
21 cm – 8 1/4"	<b>12.21.76</b>	<b>12.21.77</b>	<b>12.21.80</b>	<b>12.21.81</b>

15 cm – 6"	<b>12.15.56</b>	<b>12.15.57</b>			
18 cm – 7 1/8"	<b>12.18.56</b>	<b>12.18.57</b>	<b>12.18.60</b>	<b>12.18.61</b>	
21 cm – 8 1/4"	<b>12.21.56</b>	<b>12.21.57</b>	<b>12.21.60</b>	<b>12.21.61</b>	

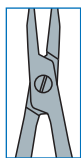

0,4 mm



0,4 mm



0,5 mm



0,5 mm



13 cm – 5 1/8"	<b>12.12.56</b>	<b>12.12.57</b>		<b>12.12.61</b>
15 cm – 6"	<b>12.15.78</b>	<b>12.15.79</b>		
18 cm – 7 1/8"	<b>12.18.78</b>	<b>12.18.79</b>	<b>12.18.82</b>	<b>12.18.83</b>
21 cm – 8 1/4"	<b>12.21.78</b>	<b>12.21.79</b>	<b>12.21.82</b>	<b>12.21.83</b>

15 cm – 6"	<b>12.15.66</b>	<b>12.15.67</b>			
18 cm – 7 1/8"	<b>12.18.66</b>	<b>12.18.67</b>	<b>12.18.68</b>	<b>12.18.69</b>	
21 cm – 8 1/4"	<b>12.21.66</b>	<b>12.21.67</b>	<b>12.21.70</b>	<b>12.21.71</b>	

mit Sperre  
with catch  
con cremallera  
avec crémaillère  
con cremagliera

Beschichtung mit Diamantstaub  
Coating with diamond dust  
Recubierto con polvo de diamante  
Revêtement avec de poussière de diamant  
Rivestito con polvere di diamante

Rundgriff  
Round handle  
Mango redondo  
Manche rond  
Manico rotondo

**A05**

**Mikro-Nadelhalter**  
**Micro Needle Holders**  
**Micro porta-agujas**  
**Micro porte-aiguilles**  
**Micro portaghi**

**micro 2000**

15 cm – 6"  
**12.15.70**



15 cm – 6"  
**12.15.71**



18 cm – 7 1/8"  
**12.18.70**



18 cm – 7 1/8"  
**12.18.71**

**micro 2000**

15 cm – 6"  
**12.15.72**



15 cm – 6"  
**12.15.73**



18 cm – 7 1/8"  
**12.18.72**



18 cm – 7 1/8"  
**12.18.73**



18 cm – 7 1/8"  
**12.18.74**



18 cm – 7 1/8"  
**12.18.75**

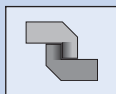

mit Sperre  
 with catch  
 con cremallera  
 avec crémaillère  
 con cremagliera



Beschichtung mit Diamantstaub  
 Coating with diamond dust  
 Recubierto con polvo de diamante  
 Revêtement avec de poussière de diamant  
 Rivestito con polvere di diamante



Instrumente mit blau eloxierten  
 Leichtmetall-Griffen für höchste  
 Präzision und Arbeitskomfort.

Instruments with blue anodized light  
 metal handles for maximum precision  
 and working convenience.

Instrumentos con mangos de metal  
 ligero anodizados en azul para la  
 precisión y el confort de trabajo  
 máximo.

Instruments avec manches en métal  
 léger anodisés en bleu pour un  
 maximum de précision et de confort  
 à l'utilisation.

Strumenti con manici di metallo  
 leggero anodizzati blu per una  
 precisione massima e conforto  
 lavorativo.

**Mikro-Nadelhalter**  
**Micro Needle Holders**  
**Micro porta-agujas**  
**Micro porte-aiguilles**  
**Micro portaghi**

**A05**

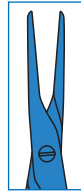

**Ti**

8 mm



15 cm – 6"  
**12.16.75**



18 cm – 7 1/8"  
**12.18.85**



21 cm – 8 1/4"  
**12.21.95**



15 cm – 6"  
**12.16.77**



18 cm – 7 1/8"  
**12.18.87**



21 cm – 8 1/4"  
**12.21.97**

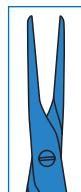

**Ti**

8 mm



15 cm – 6"  
**12.16.76**



18 cm – 7 1/8"  
**12.18.86**



21 cm – 8 1/4"  
**12.21.96**



15 cm – 6"  
**12.16.78**



18 cm – 7 1/8"  
**12.18.88**



21 cm – 8 1/4"  
**12.21.98**



# A05

**Mikro-Nadelhalter**  
**Micro Needle Holders**  
**Micro porta-agujas**  
**Micro porte-aiguilles**  
**Micro portaghi**



micro 2000

12 cm - 4¾"	12 cm - 4¾"
<b>12.12.40</b>	<b>12.12.41</b>

12 cm - 4¾"	12 cm - 4¾"
<b>12.12.42</b>	<b>12.12.43</b>

12 cm - 4¾"
<b>12.12.48</b>



micro 2000

15 cm - 6"	15 cm - 6"
<b>12.15.30</b>	<b>12.15.31</b>

15 cm - 6"	15 cm - 6"
<b>12.15.32</b>	<b>12.15.33</b>



Yasargil

a = 70 mm 16 cm - 6¼"	a = 90 mm 18,5 cm - 7¼"
<b>58.16.45</b>	<b>58.19.45</b>

a = 70 mm 16 cm - 6¼"	a = 90 mm 18,5 cm - 7¼"
<b>58.16.48</b>	<b>58.19.40</b>



Yasargil

a = 85 mm 20 cm - 8"	a = 100 mm 23 cm - 9"
<b>59.20.40</b>	<b>59.23.42</b>

a = 85 mm 20 cm - 8"	a = 100 mm 23 cm - 9"
<b>59.20.45</b>	<b>59.23.45</b>

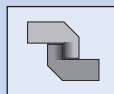

mit Sperre  
 with catch  
 con cremallera  
 avec crémaillère  
 con cremagliera

**Saug- und Spülinstrumente**  
**Suction and Irrigating Instruments**  
**Instrumentos de aspiración y de lavado**  
**Instruments à aspiration et à irrigation**  
**Strumenti per aspirazione e lavaggio**

**A06**

Konisches Saugrohr verhindert ein Verstopfen der Kanüle  
 Bajonettverschluss für schnellen Kanülenwechsel  
 Einfache Zerlegbarkeit für optimale Reinigung

Conical suction tube prevents clogging of the cannula  
 Bayonet joint for quick cannula changes  
 Easy dismantling for best possible cleaning

La cánula cónica de succión evita la obstrucción de la misma  
 Cierre de bayoneta para el cambio rápido de las cánulas  
 Fácil desmontaje para una limpieza óptima

Un tuyau conique prévient le colmatage de la canule  
 Fermeture de type baïonnette pour un remplacement rapide de la canule  
 Démontage facile pour un nettoyage optimal

Cannule d'aspirazione coniche per evitare che si otturino  
 Attacco a baionetta per una rapida sostituzione della cannula  
 Facile da smontare per una pulizia ottimale

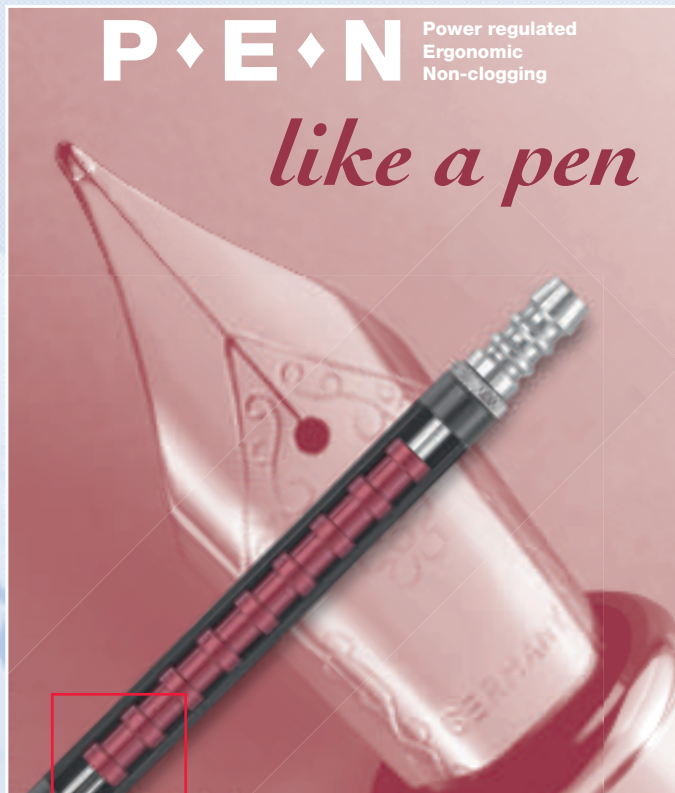

**P♦E♦N** Power regulated  
 Ergonomic  
 Non-clogging

*like a pen*

**Progressive und ergonomische Regulierung der Saugkraft**  
**Progressive and ergonomic adjustment of the suction power**  
**Regulación progresiva y ergonómica de la potencia de aspiración**  
**Réglage progressif et ergonomique de la puissance d'aspiration**  
**Regolazione progressiva ed ergonomica dell'intensità d'aspirazione**

entwickelt in Zusammenarbeit mit:  
 developed in cooperation with:  
 desarrollado en colaboración con:  
 développée en collaboration avec:  
 sviluppato in collaborazione con:

**Prof. Marco Cenzato**  
 Head of Department Neuro Surgery  
 Hospital Niguarda Ca' Granda - Milan

**A06**

**Saug- und Spülinstrumente**  
**Suction and Irrigating Instruments**  
**Instrumentos de aspiración y de lavado**  
**Instrumenti à aspiration et à irrigation**  
**Strumenti per aspirazione e lavaggio**

**P ♦ E ♦ N**

Handgriff mit drehbarem Schlauchansatz  
 Handle with rotatable tube connection  
 Mango con empalme giratorio para tubo  
 Manche avec embout de tuyau pivotant  
 Manico con attacco girevole per tubo

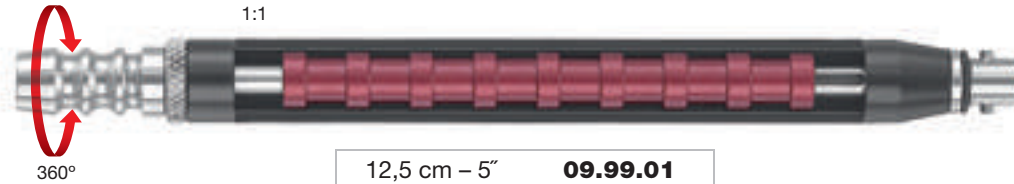
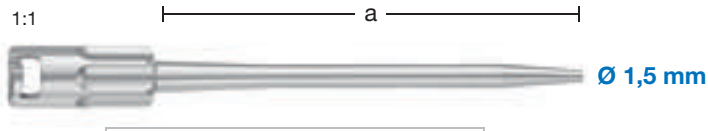
12,5 cm – 5" **09.99.01**a = 55 mm **09.99.07**a = 90 mm **09.99.08**a = 110 mm **09.99.09**

Saugkanülen (biegbar)  
 Suction cannulas (malleable)  
 Cánulas de aspiración (maleables)  
 Canules à aspiration (malléables)  
 Cannule per aspirazione (malleabili)

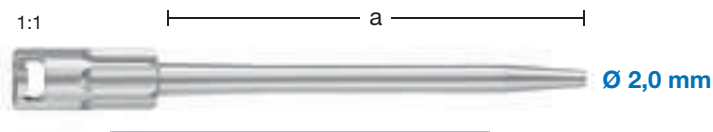
a = 55 mm **09.99.11**a = 90 mm **09.99.12**a = 110 mm **09.99.13**

Ersatz-O-Ring  
 Replacement O-ring  
 Anillo tórico de repuesto  
 Joint torique de rechange  
 Guarnizione circolare di ricambio

**P**<sub>10</sub>**909.81.01**

Verpackungseinheit "X" Stück  
 Packing unit "X" pieces  
 Paquete de "X" unidades  
 Emballage de "X" pièces  
 Confezione da "X" pezzi

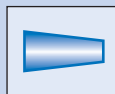

Saugkanülenrohre sind konisch  
 Conical shape of the suction cannules  
 Forma cónica de la cánulas  
 Canules de forme conique  
 Cannule di forma conica



biegbar  
 malleable  
 maleables  
 malléables  
 malleabili

**Saug- und Spülinstrumente**  
**Suction and Irrigating Instruments**  
**Instrumentos de aspiración y de lavado**  
**Instrumenti à aspiration et à irrigation**  
**Strumenti per aspirazione e lavaggio**

**A06**

Punktionskanülen  
 Puncture cannulas  
 Cánulas para punción  
 Canules à ponction  
 Cannule per puntura

1:1

♀ Luer-Lock

**Quincke**

a = 80 mm	<b>09.72.07</b>	Ø 0,7 mm
a = 90 mm	<b>09.72.08</b>	Ø 0,7 mm
a = 80 mm	<b>09.72.10</b>	Ø 1,0 mm
a = 90 mm	<b>09.72.11</b>	Ø 1,0 mm
a = 90 mm	<b>09.72.12</b>	Ø 1,2 mm
a = 100 mm	<b>09.72.13</b>	Ø 1,2 mm
a = 150 mm	<b>09.72.14</b>	Ø 1,2 mm

1:1

♀ Luer-Lock

**Tuohy**

a = 80 mm	<b>09.73.12</b>	Ø 1,30 mm
a = 80 mm	<b>09.73.14</b>	Ø 1,50 mm
a = 80 mm	<b>09.73.16</b>	Ø 1,65 mm

1:1

♀ Luer

**Bier**

a = 80 mm	<b>09.73.92</b>	Ø 1,2 mm
a = 90 mm	<b>09.73.93</b>	Ø 1,2 mm

1:1

♀ Luer-Lock

**Klima-Rosegger**

a = 35 mm	<b>09.70.18</b>	Ø 1,8 mm
-----------	-----------------	----------

graduiert in cm  
 graduated in cms  
 graduado en cm  
 graduée en cm  
 graduato in cm

1:1

♀ Luer-Lock

**Frazier**

a = 100 mm	<b>57.39.02</b>	Ø 2,0 mm
------------	-----------------	----------

**A06**

**Saug- und Spülinstrumente**  
**Suction and Irrigating Instruments**  
**Instrumentos de aspiración y de lavado**  
**Instrumenti à aspiration et à irrigation**  
**Strumenti per aspirazione e lavaggio**

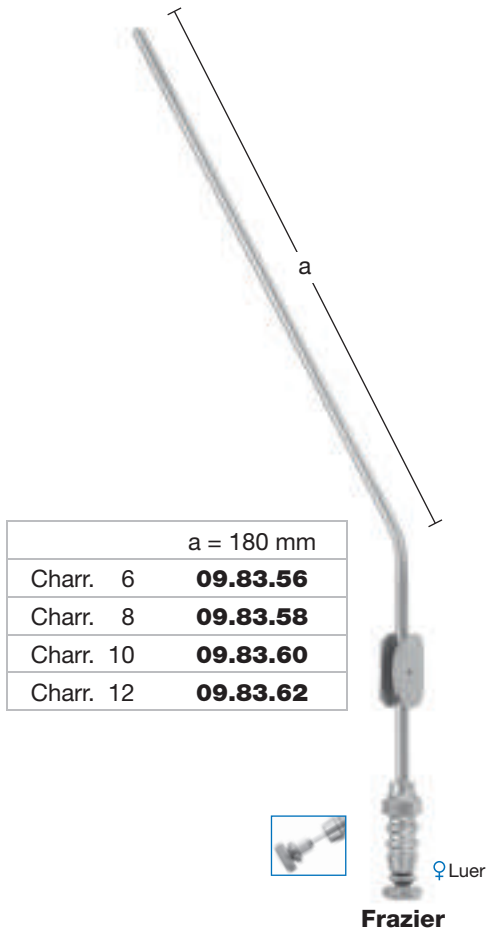
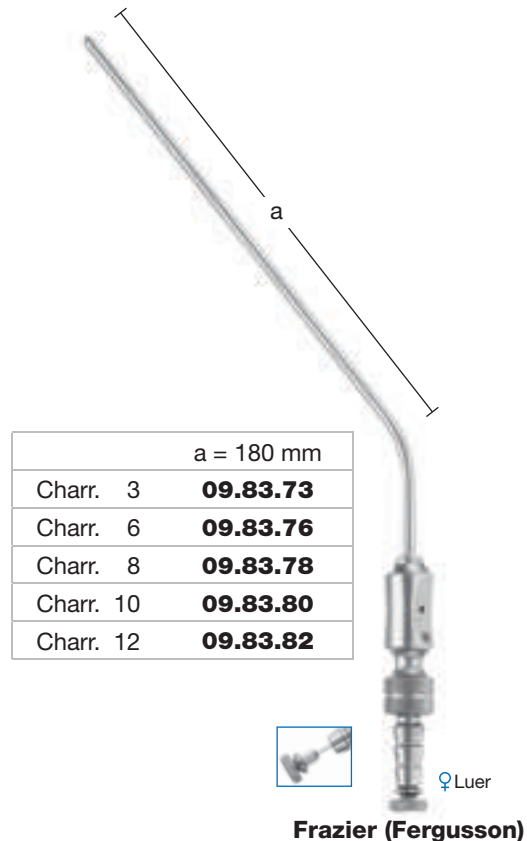
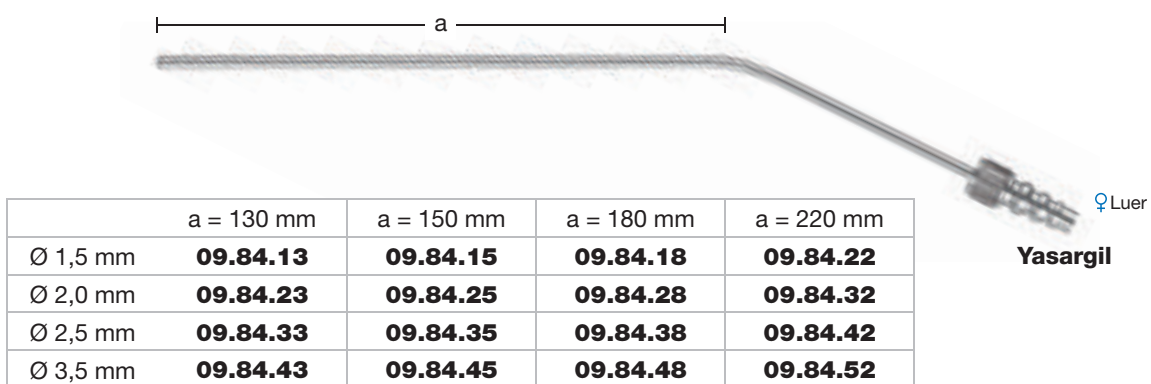
**Frazier****Frazier (Fergusson)****Yasargil**

mit Mandrin  
 with guide  
 con mandril  
 avec mandrin  
 con mandrino



**Saug- und Spülinstrumente**  
**Suction and Irrigating Instruments**  
**Instrumentos de aspiración y de lavado**  
**Instrumenti à aspiration et à irrigation**  
**Strumenti per aspirazione e lavaggio**

**A06**

Bajonett-Saugkanüle  
 Bayonet suction cannula  
 Cánula de aspiración en forma bayoneta  
 Canule à aspiration en forme baïonnette  
 Cannula per aspirazione a forma di baionetta



Charr. 9	<b>09.83.99</b>	22,5 cm – 9"
----------	-----------------	--------------

„Tropfen“-Saugkanülen (biegbar)  
 “Drop-shape design” suction cannulas (malleable)  
 Cánulas de aspiración con dispositivo en forma de “gota” (maleables)  
 Canules à aspiration avec dispositif en forme de “goutte” (malléables)  
 Cannule per aspirazione con dispositivo a forma di “goccia” (malleabili)



Saugkraft ist durch die Saugunterbrechung regulierbar  
 Interruption of suction power by taking off the thumb  
 Interrupción de la fuerza de succión al destapar la apertura  
 Réglage de la succion en retirant le doigt du dispositif  
 Controllo della capacità di aspirazione tramite il dispositivo



	a = 120 mm	a = 150 mm
Ø 1,0 mm	<b>58.24.15</b>	<b>58.24.21</b>
Ø 1,5 mm	<b>58.24.16</b>	<b>58.24.22</b>
Ø 2,0 mm	<b>58.24.17</b>	<b>58.24.23</b>
Ø 2,5 mm	<b>58.24.18</b>	<b>58.24.24</b>
Ø 3,0 mm	<b>58.24.19</b>	<b>58.24.25</b>
Ø 4,0 mm	<b>58.24.20</b>	<b>58.24.26</b>
Ø 5,0 mm	<b>58.24.30</b>	<b>58.24.31</b>

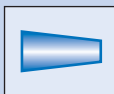

Saugkanülenrohre sind konisch  
 Conical shape of the suction cannules  
 Forma cónica de la cánula  
 Canules de forme conique  
 Cannule di forma conica



mit Mandrin  
 with guide  
 con mandril  
 avec mandrin  
 con mandrino



biegbar  
 malleable  
 maleables  
 malléables  
 malleabili

# medicon-cat NEURO

Für unsere Partner organisieren wir Fortbildungsveranstaltungen und bieten Seminare an. Auch weiterbildende Literatur und CD's stellen wir gerne zur Verfügung.

We organise training courses and offer seminars for our business partners. We also assist our clients with sales tools like literature and CDs.

Ofrecemos seminarios y organizamos cursillos de perfeccionamiento para nuestros clientes. También ponemos a su disposición literatura y CDs.

Pour nos partenaires, nous organisons des séminaires de formation continue. Nous proposons également des livres et des CDRoms de perfectionnement, car, comme nous le savons, le service relie les hommes.

Organizziamo corsi di perfezionamento professionale per i nostri partner ed offriamo seminari. Mettiamo a disposizione volentieri anche letteratura di perfezionamento professionale e CD.



451.07.00

**Atraumatische Bulldog-Klemmen**  
**Atraumatic Bulldog Clamps**  
**Clamps Bulldog atraumáticas**  
**Clamps Bulldog atraumatiques**  
**Pinze Bulldog atraumatiche**

**A07**

- ▶ Delikate Modelle mit geringem Gewicht und differenzierter Schließkraft für Vene und Arterie
- ▶ Delicate types with light weight and different closing pressure for veins and arteries
- ▶ Modelos delicados con peso mínimo y fuerza de cierre diferenciada para venas y arterias
- ▶ Modèles délicats avec poids réduit et forces différentes de fermeture pour veines et pour artères
- ▶ Modelli delicati con peso minimo e forza di chiusura differenziata per vene ed arterie

**Ti**

1:1

3 cm – 1 1/8" <b>15.04.30</b>	3,5 cm – 1 3/8" <b>15.04.35</b>	4 cm – 1 1/2" <b>15.04.40</b>	5 cm – 2" <b>15.04.50</b>	
3 cm – 1 1/8" <b>15.04.31</b>	3,5 cm – 1 3/8" <b>15.04.36</b>	4 cm – 1 1/2" <b>15.04.41</b>	5 cm – 2" <b>15.04.51</b>	

**Ti**

1:1

3 cm – 1 1/8" <b>15.05.30</b>	3,5 cm – 1 3/8" <b>15.05.35</b>	4 cm – 1 1/2" <b>15.05.40</b>	5 cm – 2" <b>15.05.50</b>	
3 cm – 1 1/8" <b>15.05.31</b>	3,5 cm – 1 3/8" <b>15.05.36</b>	4 cm – 1 1/2" <b>15.05.41</b>	5 cm – 2" <b>15.05.51</b>	

**Ti**

1:1

3 cm – 1 1/8" <b>15.07.30</b>	3,5 cm – 1 3/8" <b>15.07.35</b>	4 cm – 1 1/2" <b>15.07.40</b>	5 cm – 2" <b>15.07.50</b>	
3 cm – 1 1/8" <b>15.07.31</b>	3,5 cm – 1 3/8" <b>15.07.36</b>	4 cm – 1 1/2" <b>15.07.41</b>	5 cm – 2" <b>15.07.51</b>	

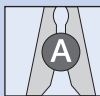

starke Schließkraft, für Arterien  
 strong closing pressure, for arteries  
 fuerza de cierre alta, para arterias  
 force de fermeture forte, pour artères  
 forza di chiusura forte, per arterie

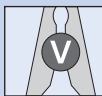

schwache Schließkraft, für Venen  
 soft closing pressure, for veins  
 fuerza de cierre baja, para venas  
 force de fermeture faible, pour veines  
 forza di chiusura debole, per vene



Titan  
 Titanium  
 Titano  
 Titane  
 Titanio



**Bulldog-Klemmen**  
**Bulldog Clamps**  
**Clamps Bulldog**  
**Clamps Bulldog**  
**Pinze Bulldog**

**A07**



1:1

**Diethrich**



4,5 cm – 1¾"  
F = 100 g  
**15.10.08**

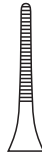

5 cm – 2"  
F = 100 g  
**15.10.12**

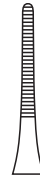

5,5 cm – 2⅛"  
F = 100 g  
**15.10.16**



1:1

**Diethrich**



4,5 cm – 1¾"  
F = 100 g  
**15.11.08**

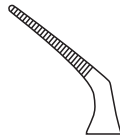

5 cm – 2"  
F = 100 g  
**15.11.12**

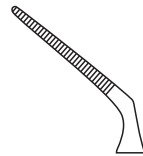

5,5 cm – 2⅛"  
F = 100 g  
**15.11.16**



1:1

**Dieffenbach**



3,8 cm – 1½"  
**15.10.38**



5,1 cm – 2"  
**15.10.51**



1:1

**Dieffenbach**



3,8 cm – 1½"  
**15.11.38**



5,1 cm – 2"  
**15.11.51**



Gewicht  
Weight  
Peso  
Poids  
Peso

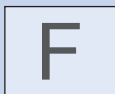

Schließkraft  
Closing pressure  
Fuerza de cierre  
Force de fermeture  
Forza di chiusura

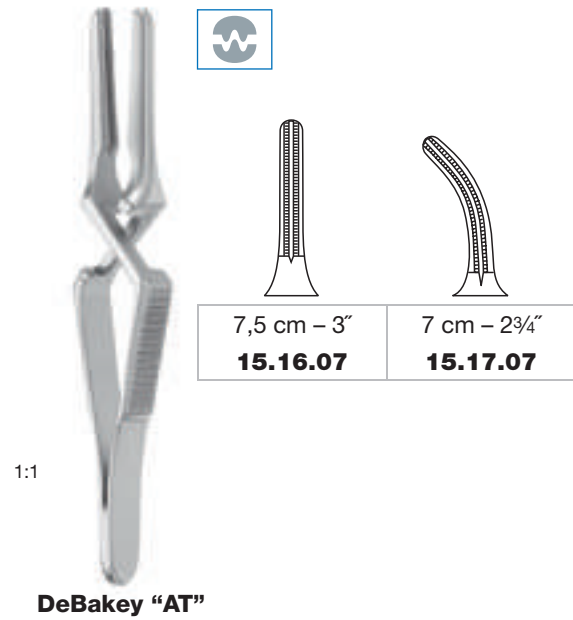
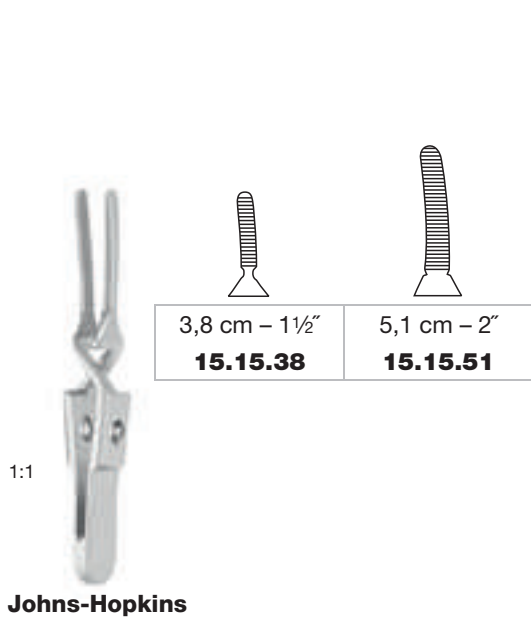

Anlege- und Entnahmezange  
 Applying and removing forceps  
 Pinza para aplicar y quitar  
 Pince à poser et retirer  
 Pinza per applicare e togliere

für Bulldog-Klemmen:  
 for Bulldog clamps:  
 para clamps Bulldog:  
 pour clamps Bulldog:  
 per pinze Bulldog:

**Johns-Hopkins**  
**DeBakey "AT"**

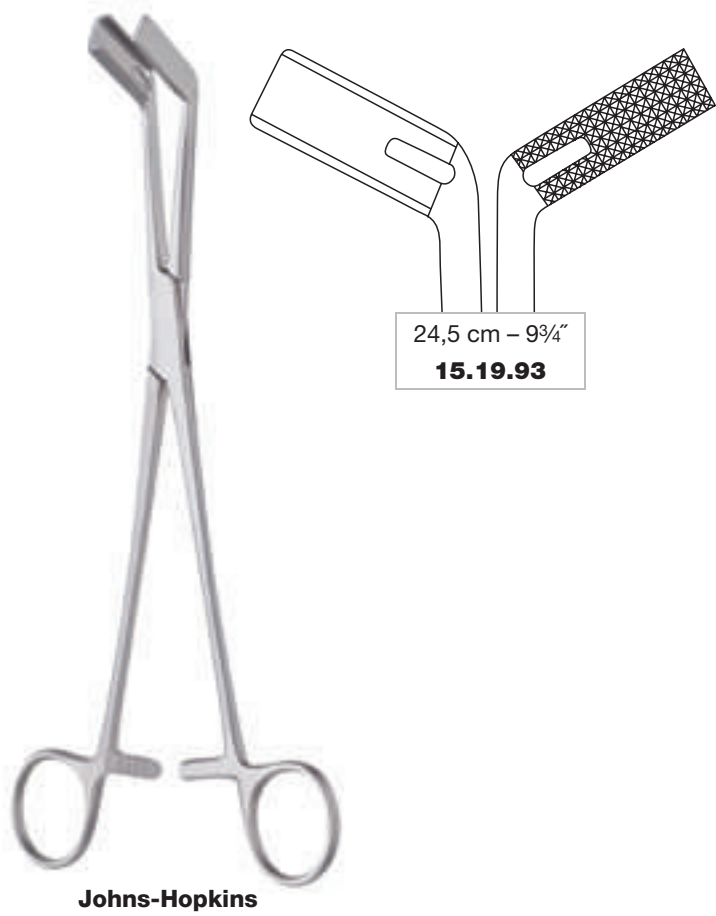

**"AT"**  
  
 Atraumatiche Riefung  
 Atraumatic serration  
 Estrías atraumáticas  
 Striure atraumatique  
 Zigrinatura atraumatica



A07

**Arterienklemmen**  
**Hemostatic Forceps and Scalp Forceps**  
**Pinzas hemostáticas y pinzas para cuero cabelludo**  
**Pinces hémostatiques et pinces pour cuir chevelu**  
**Pinze emostatiche e pinze per cuoio capelluto**

Arterienklemmen  
 Hemostatic forceps  
 Pinzas hemostáticas  
 Pinces hémostatiques  
 Pinze emostatiche

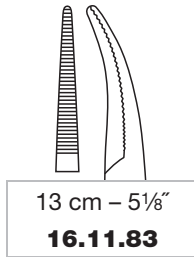
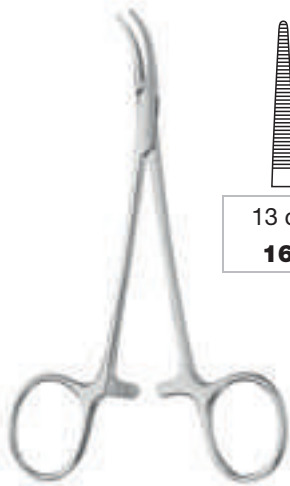

**Dandy-Baby**

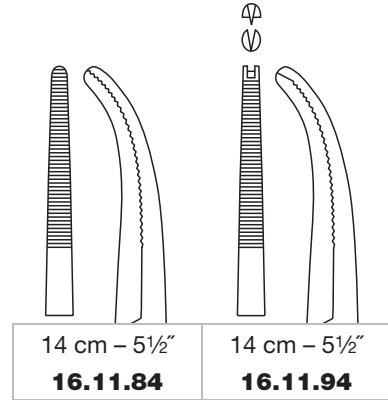
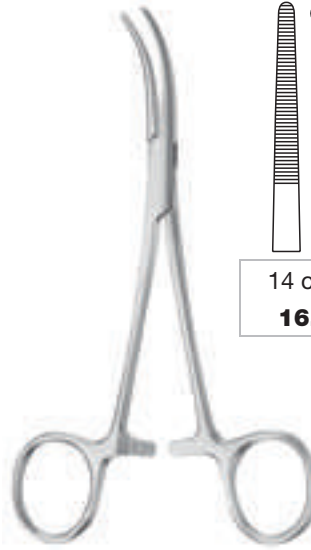

**Dandy**

Kopfhautklemmen  
 Scalp forceps  
 Pinzas para cuero cabelludo  
 Pinces pour cuir chevelu  
 Pinze per cuoio capelluto

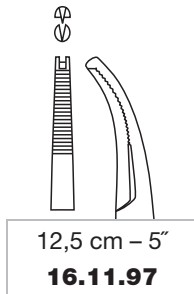

**Raimondi**

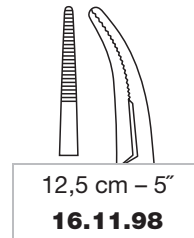
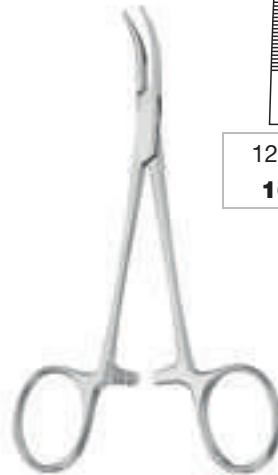

**Hoen**



**Gefäßclips**  
**Vessel Clips**  
**Clips vasculares**  
**Clips vasculaires**  
**Clip vascolari**

**A08**

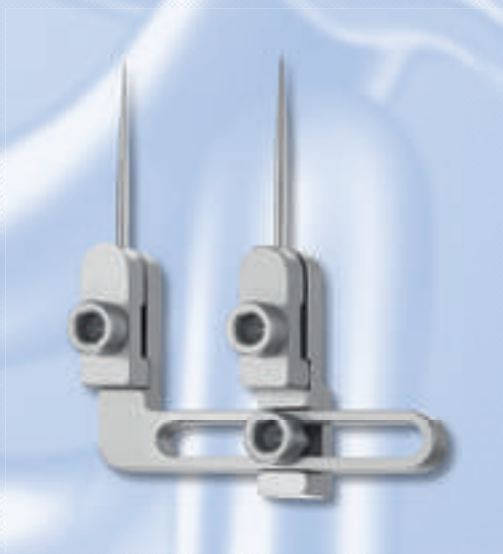



**Titan-Clips**  
**Titanium Clips**  
**Clips de titanio**  
**Clips en titane**  
**Clip di titanio**

**A08**

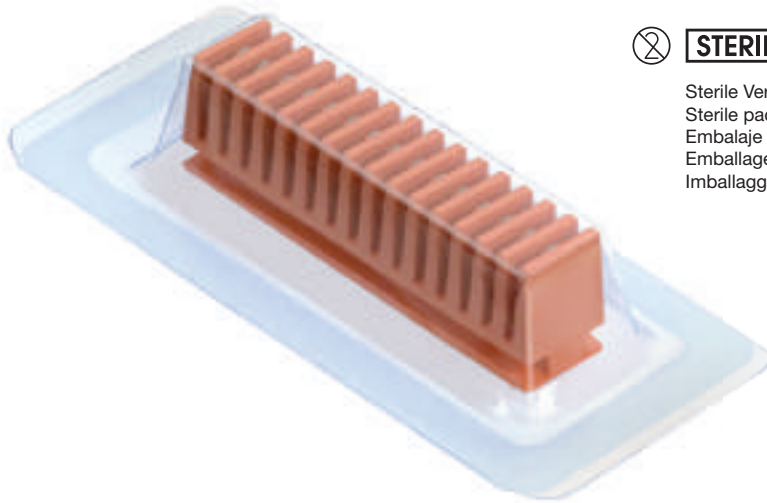

 **STERILE**

Sterile Verpackung  
Sterile packaging  
Embalaje estéril  
Emballage stérile  
Imballaggio sterile

Titan-Clips  
Titanium clips  
Clips de titanio  
Clips en titane  
Clip di titanio



1:1

  
klein  
small  
pequeño  
petit  
piccolo

 **P<sub>300</sub>**

12 × 25



**56.50.01**

  
mittel  
medium  
mediano  
moyen  
medio

 **P<sub>250</sub>**

10 × 25



**56.50.02**

  
mittelgroß  
medium large  
medio grande  
moyen grand  
medio grande

 **P<sub>160</sub>**

16 × 10



**56.50.03**

  
groß  
large  
grande  
grand  
grande

 **P<sub>150</sub>**

10 × 15



**56.50.04**

1:1

  
klein  
small  
pequeño  
petit  
piccolo

 **P<sub>240</sub>**

24 × 10



**56.50.11**

  
mittel  
medium  
mediano  
moyen  
medio

 **P<sub>200</sub>**

20 × 10



**56.50.12**

  
groß  
large  
grande  
grand  
grande

 **P<sub>120</sub>**

12 × 10



**56.50.14**

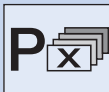

Verpackungseinheit "X" Stück  
Packing unit "X" pieces  
Paquete de "X" unidades  
Emballage de "X" pièces  
Confezione da "X" pezzi

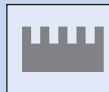

Magazine × Clips  
Storage tray × clips  
Cartucho × clips  
Cartouche × clips  
Cartuccia × clip

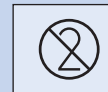

Einmalprodukt  
Single use product  
Producto para un solo uso  
Produit à usage unique  
Prodotto monouso



**Anlegezangen für Titan-Clips**  
**Applying Forceps for Titanium Clips**  
**Pinzas para aplicar para clips de titanio**  
**Pinces à poser pour clips en titane**  
**Pinze per applicare per clip di titanio**

**A08**



**Clipmagazine und Anlegezangen mit gleicher Farbcodierung**  
**Clip storage trays and applying forceps with matching color code**  
**Dispositivo de clips y pinzas aplicadoras con la misma codificación de color**  
**Magasins de clips et pinces à appliquer avec le même code couleur**  
**Cartucce per clip e pinze per applicare con codice colore uguale**

Anlegezangen  
 Applying forceps  
 Pinzas para aplicar  
 Pinces à appliquer  
 Pinze per applicare

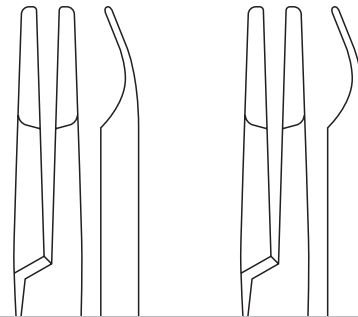

15 cm – 6"	15 cm – 6"
<b>56.50.15</b>	<b>56.50.25</b>
19,5 cm – 7¾"	19,5 cm – 7¾"
<b>56.50.19</b>	<b>56.50.29</b>

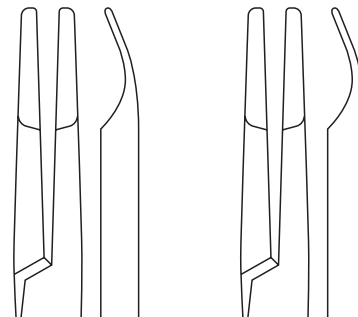

20,5 cm – 8⅛"	20,5 cm – 8⅛"
<b>56.50.30</b>	<b>56.50.40</b>



# A08

**Mikro-Gefäßclips und Anlegepinzette**  
**Micro Vessel Clips and Applying Forceps**  
**Micro clips vasculares y pinza para aplicar**  
**Micro clips vasculaires et pince à appliquer**  
**Micro clip vascolari e pinza per applicare**

Clips (einzeln)  
 Clips (single)  
 Clips (singular)  
 Clips (seuls)  
 Clip (singola)



2:1

Mehdorn

1,0 mm



a = 4,0 mm  
 F = 10-15 g

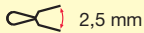

**56.80.04**

1,4 mm



a = 4,0 mm  
 F = 15-20 g

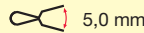

**56.81.04**

1,0 mm



a = 6,0 mm  
 F = 10-15 g

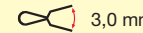

**56.80.06**

1,4 mm



a = 6,0 mm  
 F = 15-20 g

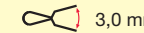

**56.81.06**

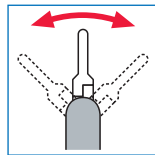

Anlegepinzette  
 Applying forceps  
 Pinza para aplicar  
 Pince à appliquer  
 Pinza per applicare

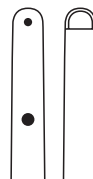

14,5 cm – 5¾"  
**56.80.14**

Mehdorn

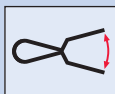

Öffnungsweite  
 Opening width  
 Apertura de ancho  
 Largeur d'ouverture  
 Larghezza dell'apertura

F

Schließkraft  
 Closing pressure  
 Fuerza de cierre  
 Force de fermeture  
 Forza di chiusura



Verpackungseinheit "X" Stück  
 Packing unit "X" pieces  
 Paquete de "X" unidades  
 Emballage de "X" pièces  
 Confezione da "X" pezzi



**Mikro-Gefäßclips und Anlegepinzetten**  
**Micro Vessel Clips and Applying Forceps**  
**Micro clips vasculares y pinzas para aplicar**  
**Micro clips vasculaires et pinces à appliquer**  
**Micro clip vascolari e pinze per applicare**

**A08**

Clips (einzeln)  
 Clips (single)  
 Clips (singular)  
 Clips (seuls)  
 Clip (singola)

	a = 8 mm ∅ 0,4 - 1,0 mm	a = 11 mm ∅ 0,6 - 1,5 mm	a = 14 mm ∅ 1,0 - 2,25 mm
<b>P</b>	<b>56.85.07</b>	<b>A</b> <b>56.85.10</b>	<b>A</b> <b>56.85.13</b>
<b>P</b>	<b>56.85.08</b>	<b>V</b> <b>56.85.11</b>	<b>V</b> <b>56.85.14</b>

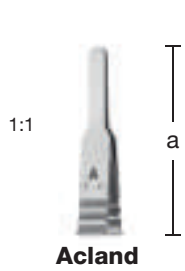

	a = 17 mm ∅ 1,0 - 2,25 mm	a = 25 mm ∅ 1,5 - 3,5 mm	a = 36 mm ∅ 2,0 - 5,0 mm
<b>P</b>	<b>56.85.16</b>	<b>A</b> <b>56.85.18</b>	<b>A</b> <b>56.86.36</b>
<b>P</b>	<b>56.85.17</b>	<b>V</b> <b>56.85.19</b>	<b>V</b> <b>56.86.37</b>

Anlegepinzetten  
 Applying forceps  
 Pinzas para aplicar  
 Pincés à appliquer  
 Pinze per applicare

8 - 11 mm	14 - 36 mm	8 - 36 mm
14,5 cm - 5¾"	14,5 cm - 5¾"	11 cm - 4½"
<b>56.85.91</b>	<b>56.85.93</b>	<b>56.85.98</b>
<b>Acland</b>	<b>Acland</b>	<b>Acland</b>



Gefäßdurchmesser  
 Vessel diameter  
 Diámetro del vaso  
 Diamètre du vaisseau  
 Diametro del vaso

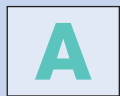

für Arterien  
 for arteries  
 para arterias  
 pour artères  
 per arterie



für Venen  
 for veins  
 para venas  
 pour veines  
 per vene

**A08**

**Mikro-Gefäßclips und Anlegepinzetten**  
**Micro Vessel Clips and Applying Forceps**  
**Micro clips vasculares y pinzas para aplicar**  
**Micro clips vasculaires et pinces à appliquer**  
**Micro clip vascolari e pinze per applicare**

Clips (einzeln)  
 Clips (single)  
 Clips (singular)  
 Clips (seuls)  
 Clip (singola)



a = 6,0 mm  
 F = 30-40 g

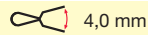

**56.87.05**



a = 9,0 mm  
 F = 30-40 g

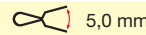

**56.87.08**

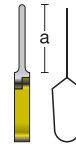

a = 9,0 mm  
 F = 20-25 g

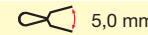

**56.87.18**

Approximator (1 Clip beweglich)  
 Approximator (1 clip mobile)  
 Aproximador (1 clip móvil)  
 Approximateur (1 clip mobile)  
 Approssimatore (1 clip mobile)

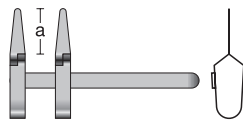
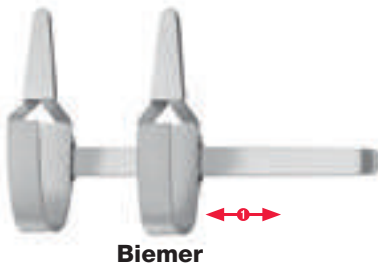

a = 6,0 mm  
 F = 30-40 g



**56.87.35**

Anlegepinzetten  
 Applying forceps  
 Pinzas para aplicar  
 Pincès à appliquer  
 Pinze per applicare

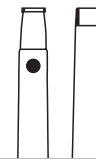

14,5 cm – 5¾"  
**56.87.45**

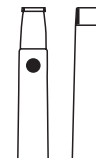

14,5 cm – 5¾"  
**56.87.46**

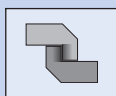

mit Sperre  
 with catch  
 con cremallera  
 avec crémaillère  
 con cremagliera

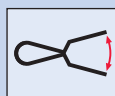

Öffnungsweite  
 Opening width  
 Apertura de ancho  
 Largeur d'ouverture  
 Larghezza dell'apertura

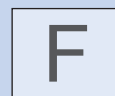

Schließkraft  
 Closing pressure  
 Fuerza de cierre  
 Force de fermeture  
 Forza di chiusura

**Mikro-Gefäßclips und Anlegepinzetten**  
**Micro Vessel Clips and Applying Forceps**  
**Micro clips vasculares y pinzas para aplicar**  
**Micro clips vasculaires et pinces à appliquer**  
**Micro clip vascolari e pinze per applicare**

**A08**

Approximatoren (2 Clips beweglich)  
 Approximators (2 clips mobile)  
 Aproximadores (2 clips móviles)  
 Approximateurs (2 clip mobiles)  
 Approssimatori (2 clip mobili)

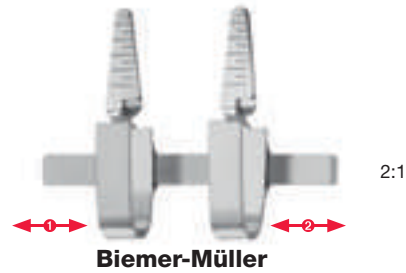

a = 6,0 mm  
 F = 25-30 g  
 3,0 mm  
**56.74.06**

a = 9,0 mm  
 F = 25-30 g  
 5,0 mm  
**56.74.09**

a = 7,5 mm  
 F = 25-30 g  
 5,0 mm  
**56.75.09**

a = 7,0 mm  
 F = 25-30 g  
 5,0 mm  
**56.76.09**

a = 7,0 mm  
 F = 25-30 g  
 5,0 mm  
**56.77.09**

Anlegepinzetten  
 Applying forceps  
 Pinzas para aplicar  
 Pince à appliquer  
 Pinze per applicare

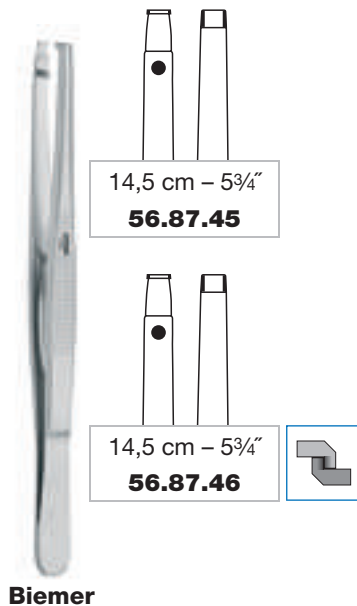

mit Sperre  
 with catch  
 con cremallera  
 avec crémaillère  
 con cremagliera

Öffnungsweite  
 Opening width  
 Apertura de ancho  
 Largeur d'ouverture  
 Larghezza dell'apertura

Schließkraft  
 Closing pressure  
 Fuerza de cierre  
 Force de fermeture  
 Forza di chiusura

**A08**

**Mikro-Gefäßclips und Anlegepinzetten**  
**Micro Vessel Clips and Applying Forceps**  
**Micro clips vasculares y pinzas para aplicar**  
**Micro clips vasculaires et pinces à appliquer**  
**Micro clip vascolari e pinze per applicare**

Approximatoren (2 Clips beweglich)  
 Approximators (2 clips mobile)  
 Aproximadores (2 clips móviles)  
 Approximateurs (2 clip mobiles)  
 Approssimatori (2 clip mobili)

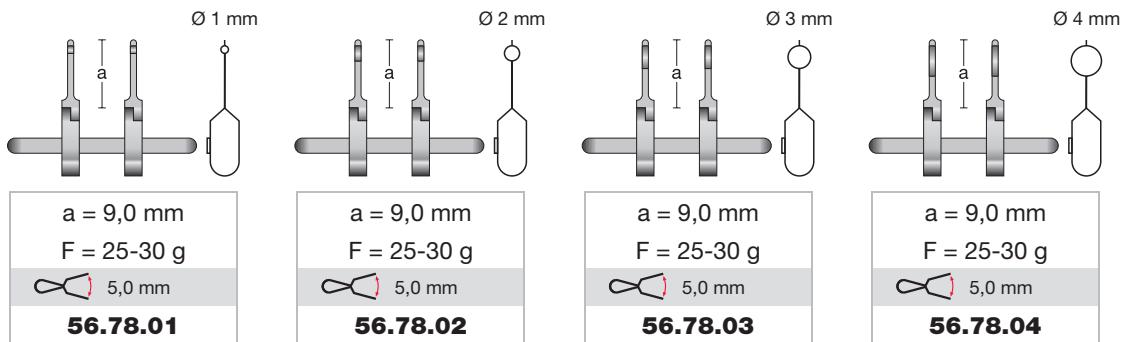
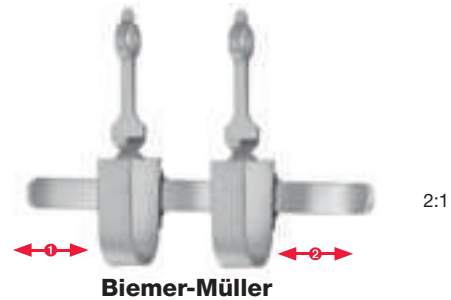

Anlegepinzetten  
 Applying forceps  
 Pinzas para aplicar  
 Pince à appliquer  
 Pinze per applicare

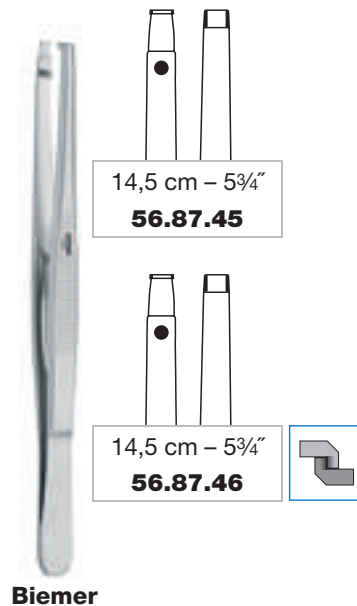

14,5 cm – 5¾"  
**56.87.45**

14,5 cm – 5¾"  
**56.87.46**

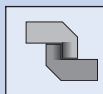

mit Sperre  
 with catch  
 con cremallera  
 avec crémaillère  
 con cremagliera

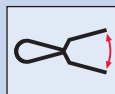

Öffnungsweite  
 Opening width  
 Apertura de ancho  
 Largeur d'ouverture  
 Larghezza dell'apertura



Schließkraft  
 Closing pressure  
 Fuerza de cierre  
 Force de fermeture  
 Forza di chiusura

**Mikro-Gefäßclips und Anlegepinzetten**  
**Micro Vessel Clips and Applying Forceps**  
**Micro clips vasculares y pinzas para aplicar**  
**Micro clips vasculaires et pinces à appliquer**  
**Micro clip vascolari e pinze per applicare**

**A08**

Approximatoren (2 Clips beweglich)  
 Approximators (2 clips mobile)  
 Aproximadores (2 clips móviles)  
 Approximateurs (2 clip mobiles)  
 Approssimatori (2 clip mobili)

a = 8 mm Ø 0,4 - 1,0 mm	a = 11 mm Ø 0,6 - 1,5 mm	a = 14 mm Ø 1,0 - 2,25 mm
<b>A</b> 56.85.47	<b>A</b> 56.85.50	<b>A</b> 56.85.53
<b>V</b> 56.85.48	<b>V</b> 56.85.51	<b>V</b> 56.85.54

a = 17 mm Ø 1,0 - 2,25 mm	a = 25 mm Ø 1,5 - 3,5 mm	a = 36 mm Ø 2,0 - 5,0 mm
<b>A</b> 56.85.56	<b>A</b> 56.85.58	<b>A</b> 56.86.58
<b>V</b> 56.85.57	<b>V</b> 56.85.59	<b>V</b> 56.86.59

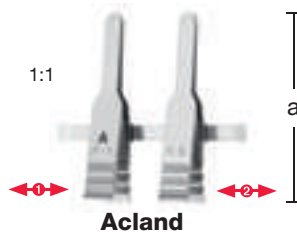

Anlegepinzetten  
 Applying forceps  
 Pinzas para aplicar  
 Pincès à appliquer  
 Pinze per applicare

8 - 11 mm 14,5 cm – 5¾"	14 - 36 mm 14,5 cm – 5¾"	8 - 36 mm 11 cm – 4½"
<b>56.85.91</b>	<b>56.85.93</b>	<b>56.85.98</b>
<b>Acland</b>	<b>Acland</b>	<b>Acland</b>



Gefäßdurchmesser  
 Vessel diameter  
 Diámetro del vaso  
 Diamètre du vaisseau  
 Diametro del vaso

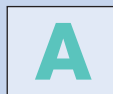

für Arterien  
 for arteries  
 para arterias  
 pour artères  
 per arterie



für Venen  
 for veins  
 para venas  
 pour veines  
 per vene

**A08**

**Mikro-Gefäßclips**  
**Micro Vessel Clips**  
**Micro clips vasculares**  
**Micro clips vasculaires**  
**Micro clip vascolari**

Nerv-Approximator (1 Clip beweglich)  
 Approximator for nerves (1 clip mobile)  
 Aproximador para nervios (1 clip móvil)  
 Approximateur pour nerfs (1 clip mobile)  
 Approssimatore per nervi (1 clip mobile)

Ersatznadeln  
 Spare needles  
 Agujas de repuesto  
 Aiguilles de rechange  
 Aghi di ricambio

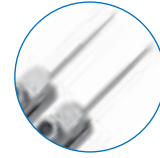

**P**<sub>2</sub> **56.79.01**

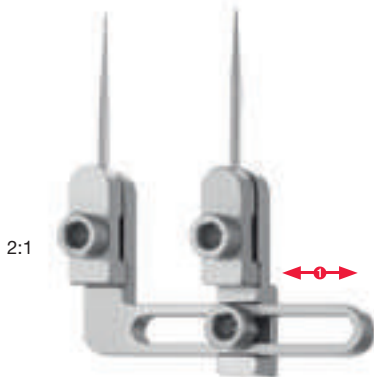
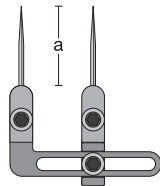
**Biemer**

a = 10 mm  
**56.79.00**

mit Schlüssel  
 with wrench  
 con llave  
 avec clé  
 con chiave

**56.87.49**

Approximator (1 Clip beweglich)  
 Approximator (1 clip mobile)  
 Aproximador (1 clip móvil)  
 Approximateur (1 clip mobile)  
 Approssimatore (1 clip mobile)

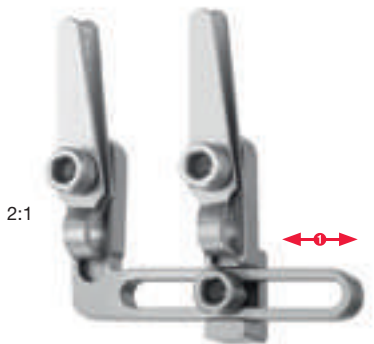
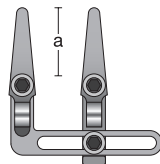
**Biemer**

a = 10 mm  
 3,0 mm  
**56.87.38**

mit Schlüssel  
 with wrench  
 con llave  
 avec clé  
 con chiave

**56.87.49**

Ersatzschlüssel  
 Replacement wrench  
 Llave de repuesto  
 Clé de rechange  
 Chiave di ricambio

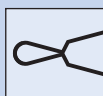

7,5 cm – 3"

**Biemer****56.87.49**

Öffnungsweite  
 Opening width  
 Apertura de ancho  
 Largeur d'ouverture  
 Larghezza dell'apertura

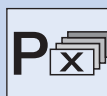

Verpackungseinheit "X" Stück  
 Packing unit "X" pieces  
 Paquete de "X" unidades  
 Emballage de "X" pièces  
 Confezione da "X" pezzi



**Wundhaken und Wundspreizer**  
**Retractors and Self-retaining Retractors**  
**Separadores y separadores autoestáticos**  
**Ecarteurs et ecarteurs autostatiques**  
**Divaricatori e divaricatori autostatici**

**A09**

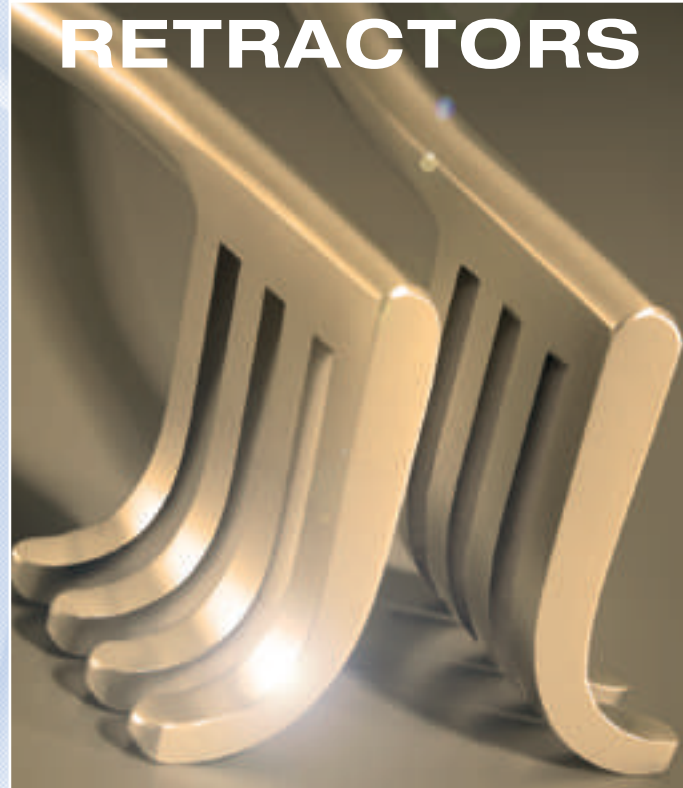



**Feine Wundhaken**  
**Delicate Retractors**  
**Separadores finos**  
**Ecarteurs fins**  
**Divaricatori delicati**

**A09**



9 × 2 mm	9 × 8 mm	9 × 10 mm	9 × 14 mm	
16 cm – 6¼"	16 cm – 6¼"	16 cm – 6¼"	16 cm – 6¼"	▲
<b>20.64.01</b>	<b>20.64.02</b>	<b>20.64.03</b>	<b>20.64.04</b>	

9 × 2 mm	9 × 8 mm	9 × 10 mm	9 × 14 mm	
16 cm – 6¼"	16 cm – 6¼"	16 cm – 6¼"	16 cm – 6¼"	▲
<b>20.65.01</b>	<b>20.65.02</b>	<b>20.65.03</b>	<b>20.65.04</b>	

7 × 1 mm	7 × 5 mm	7 × 8 mm	7 × 11 mm	
16 cm – 6¼"	16 cm – 6¼"	16 cm – 6¼"	16 cm – 6¼"	▲
<b>20.66.01</b>	<b>20.66.02</b>	<b>20.66.03</b>	<b>20.66.04</b>	

7 × 1 mm	7 × 5 mm	7 × 8 mm	7 × 11 mm	
16 cm – 6¼"	16 cm – 6¼"	16 cm – 6¼"	16 cm – 6¼"	▲
<b>20.67.01</b>	<b>20.67.02</b>	<b>20.67.03</b>	<b>20.67.04</b>	



spitz  
sharp  
aguda  
pointu  
acuta



stumpf  
blunt  
roma  
mousse  
smussa

**Wundspreizer**  
**Self-retaining Retractors**  
**Separadores autoestáticos**  
**Ecarteurs autostatiques**  
**Divaricatori autostatici**

**A09**



**Weitlaner**

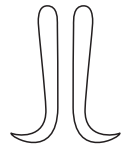

a = 18 mm  
 13 cm – 5 1/8" **24.22.13**

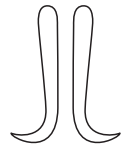

a = 18 mm  
 16,5 cm – 6 1/2" **24.22.16**

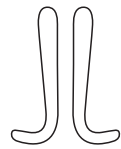

a = 18 mm  
 13 cm – 5 1/8" **24.22.14**

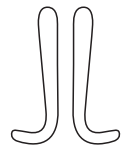

a = 18 mm  
 16,5 cm – 6 1/2" **24.22.17**

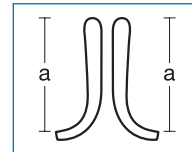

**Weitlaner**

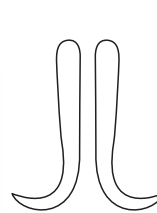

a = 20 mm  
 20 cm – 8" **24.22.20**

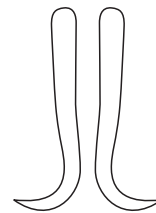

a = 25 mm  
 24 cm – 9 1/2" **24.22.24**

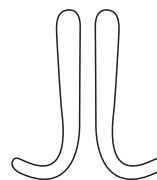
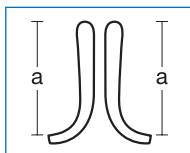

a = 20 mm  
 20 cm – 8" **24.22.21**



a = 25 mm  
 24 cm – 9 1/2" **24.22.25**

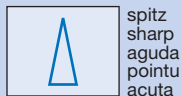

spitz  
 sharp  
 aguda  
 pointu  
 acuta



stumpf  
 blunt  
 roma  
 mousse  
 smussa



A09

**Wundspreizer**  
**Self-retaining Retractors**  
**Separadores autoestáticos**  
**Ecarteurs autostatiques**  
**Divaricatori autostatici**



**Weitlaner**

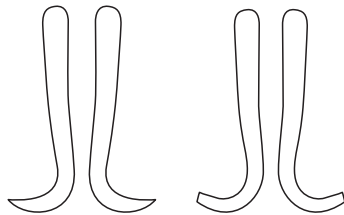

a = 25 mm 25,5 cm – 10"	a = 25 mm 25,5 cm – 10"
<b>24.22.26</b>	<b>24.22.27</b>

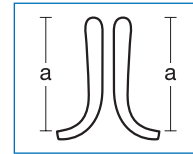

**Miskimon**

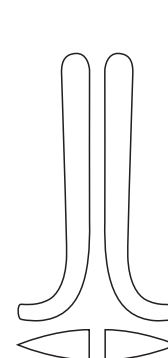

a = 33 mm 22 cm – 8¾"
<b>24.28.10</b>



spitz  
sharp  
aguda  
pointu  
acuta



stumpf  
blunt  
roma  
mousse  
smussa

**Wundspreizer**  
**Self-retaining Retractors**  
**Separadores autoestáticos**  
**Ecarteurs autostatiques**  
**Divaricatori autostatici**

**A09**

Kopfhautspreizer  
 Scalp retractor  
 Separador para el cuero cabelludo  
 Ecarteur pour le cuir chevelu  
 Divaricatore per il cuoio capelluto

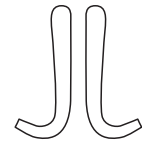
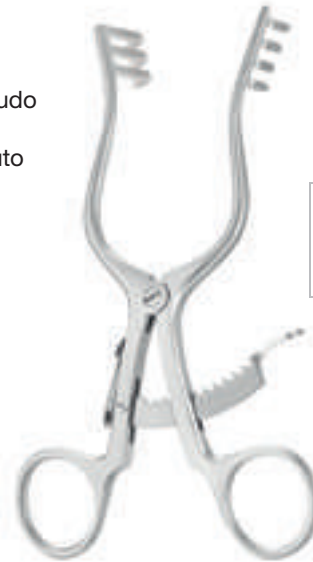
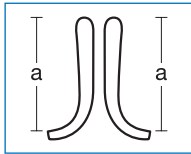

a = 16 mm  
 14 cm – 5½”  
**24.26.70**



**Contour**

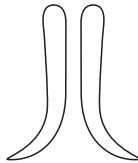

a = 20 mm  
 20 cm – 8”  
**24.28.01**

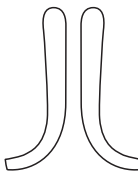

a = 20 mm  
 20 cm – 8”  
**24.28.03**



**Adson**

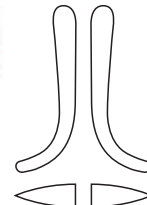

a = 20 mm  
 19 cm – 7½”  
**24.28.02**



**Adson-Anderson**



spitz  
 sharp  
 aguda  
 pointu  
 acuta



stumpf  
 blunt  
 roma  
 mousse  
 smussa



**Wundspreizer**  
**Self-retaining Retractors**  
**Separadores autoestáticos**  
**Ecarteurs autostatiques**  
**Divaricatori autostatici**

**A09**



**Weitlaner-Beckmann**

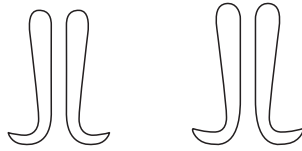

a = 16 mm 14,5 cm - 5 <sup>3</sup> / <sub>8</sub> "	a = 17 mm 17 cm - 6 <sup>3</sup> / <sub>4</sub> "
<b>24.30.13</b>	<b>24.30.16</b>

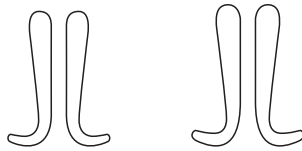

a = 16 mm 14,5 cm - 5 <sup>3</sup> / <sub>8</sub> "	a = 17 mm 17 cm - 6 <sup>3</sup> / <sub>4</sub> "
<b>24.30.14</b>	<b>24.30.17</b>

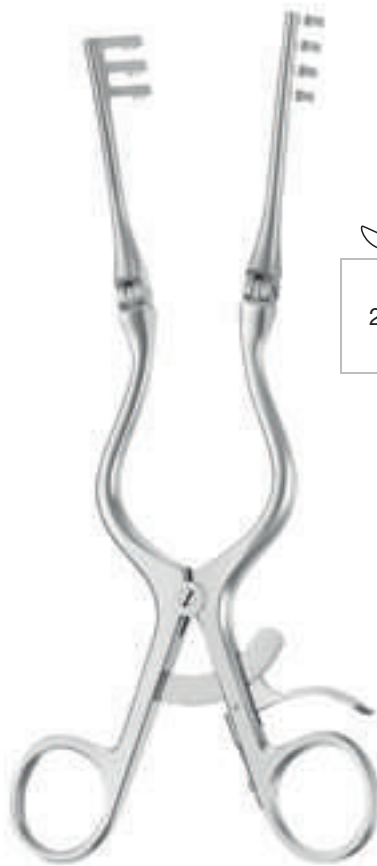
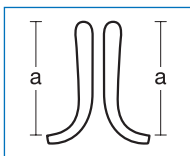
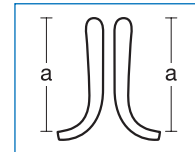

**Weitlaner-Beckmann**

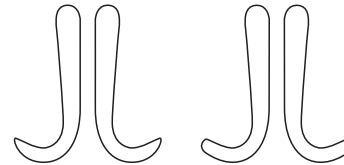

a = 19 mm 22 cm - 8 <sup>3</sup> / <sub>4</sub> "	a = 19 mm 22 cm - 8 <sup>3</sup> / <sub>4</sub> "
<b>24.30.20</b>	<b>24.30.21</b>



spitz  
sharp  
aguda  
pointu  
acuta



stumpf  
blunt  
roma  
mousse  
smussa

# ELEVATORS AND RASPATORIES



## **MICRO RASPATORIES**

Mikro-Raspatorien (siehe Seite 190-192)  
Micro raspatories (see page 190-192)  
Micro legras (véase página 190-192)  
Micro rugines (voir page 190-192)  
Micro periostotomi (vedi pagina 190-192)



**Elevatorien**  
**Elevators**  
**Elevadores**  
**Elévateurs**  
**Elevatori**

# A10



**Hoen**

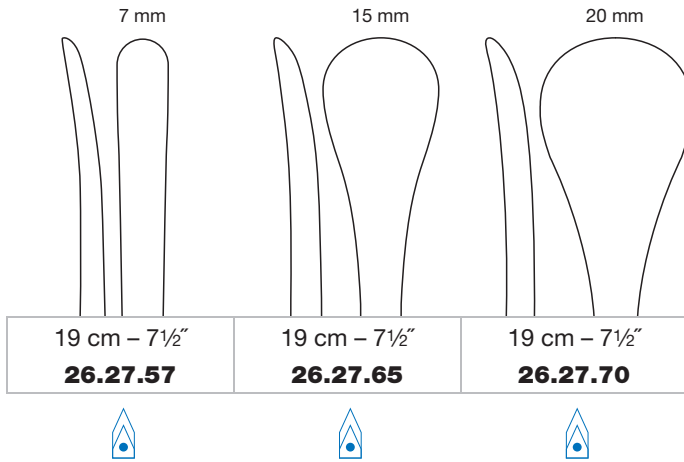

**Langenbeck**

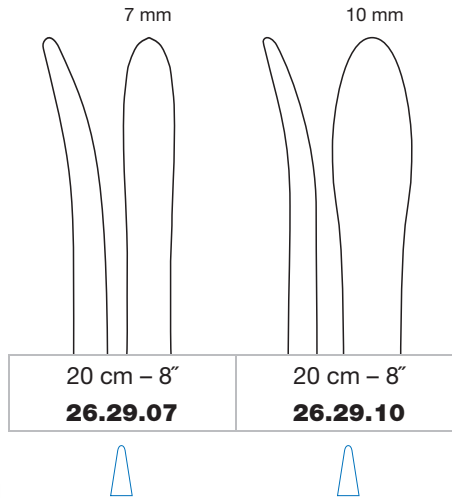

halbscharf  
semi sharp  
semi cortante  
semi tranchant  
semi tagliente



stumpf  
blunt  
roma  
mousse  
smussa



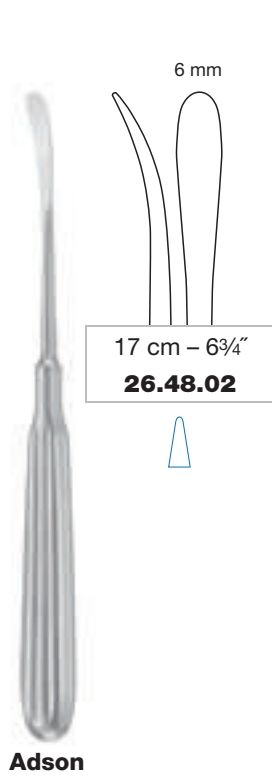

**Adson**

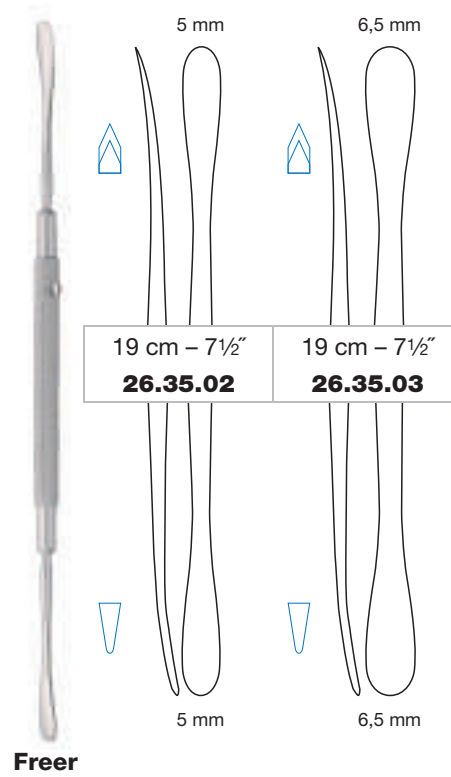

**Freer**

Septum-Elevatorium  
Septum elevator  
Elevador para el tabique nasal  
Elévateur pour la cloison nasale  
Elevatore per il setto nasale

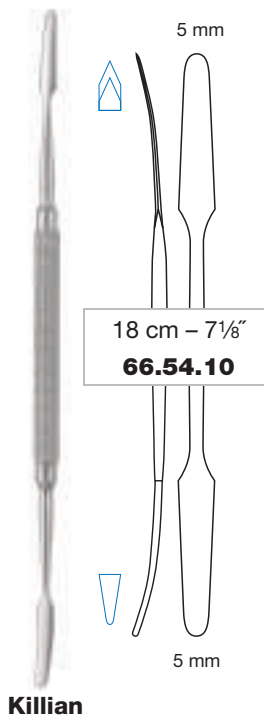

**Killian**



scharf  
sharp  
cortante  
tranchant  
tagliente



stumpf  
blunt  
roma  
mousse  
smussa



Raspatorien  
Raspatories  
Legras  
Rugines  
Periostotomi

A10

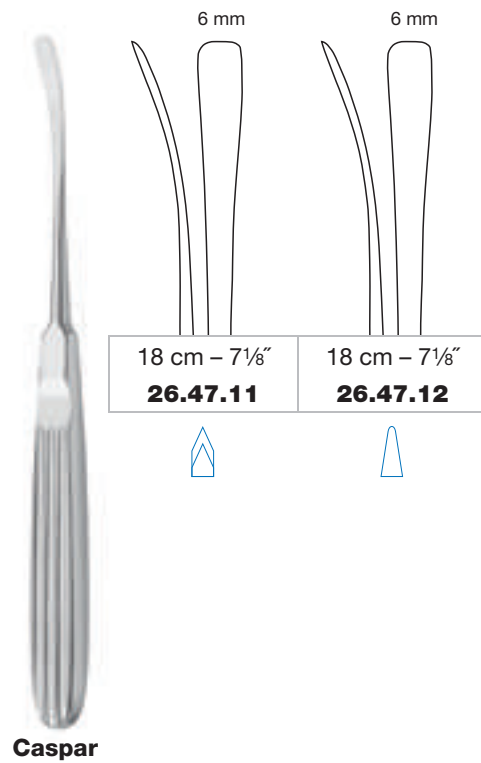
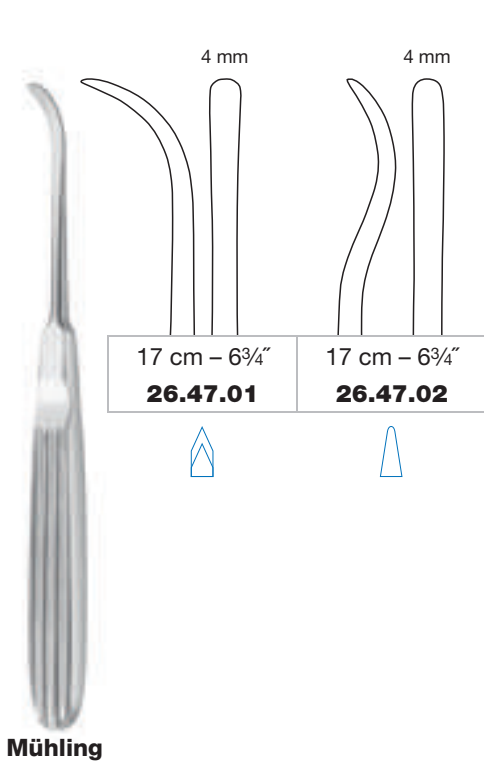
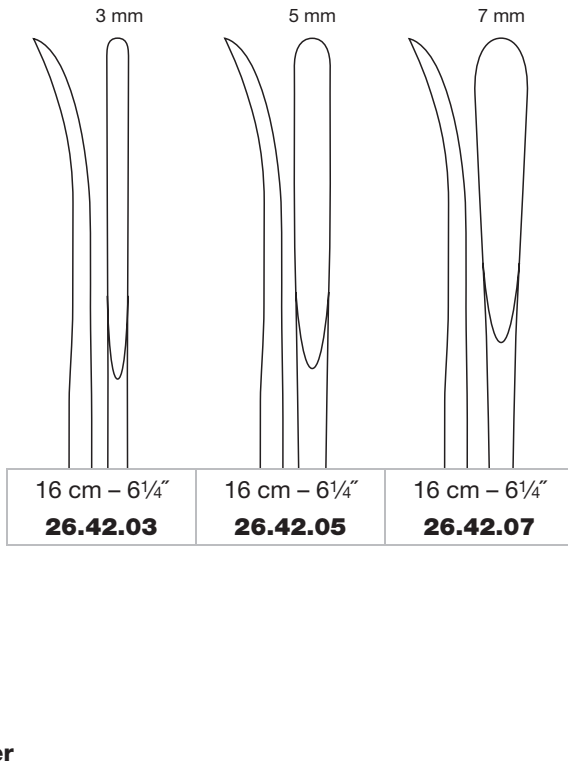
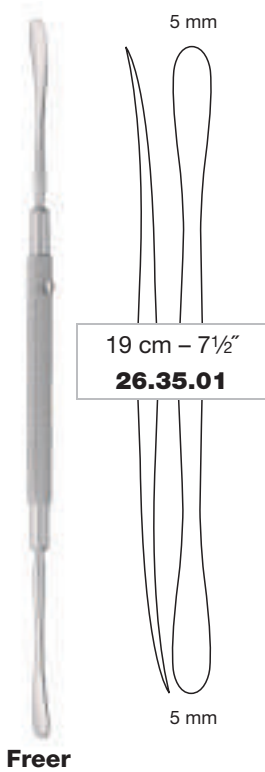

scharf  
sharp  
cortante  
tranchant  
tagliente



stumpf  
blunt  
roma  
mousse  
smussa

## MICRO RASPATORIES

Mikro-Raspatorien (siehe Seite 190-192)  
Micro raspatories (see page 190-192)  
Micro legras (véase página 190-192)  
Micro rugines (voir page 190-192)  
Micro periostotomi (vedi pagina 190-192)

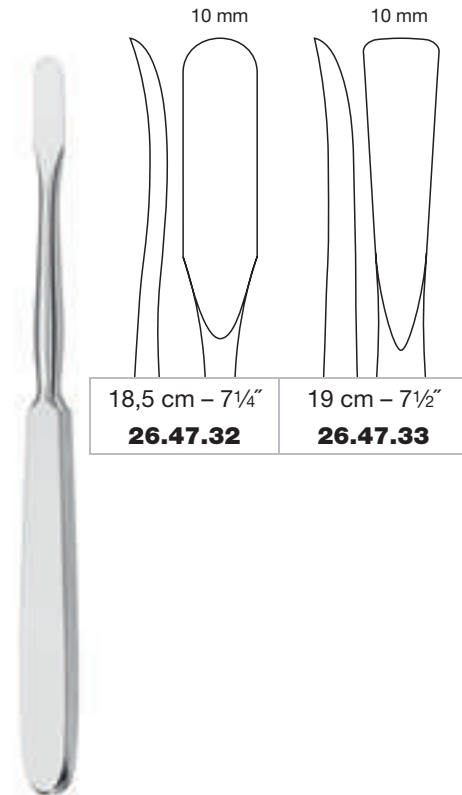

18,5 cm – 7¼"  
**26.47.32**

19 cm – 7½"  
**26.47.33**

**Krämer**

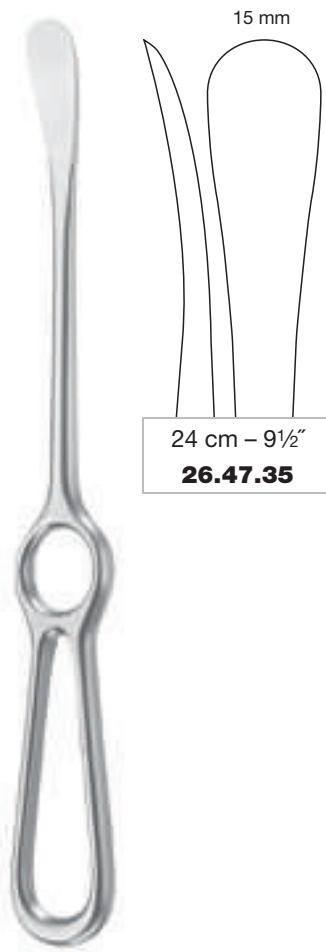

24 cm – 9½"  
**26.47.35**

**Sedillot**

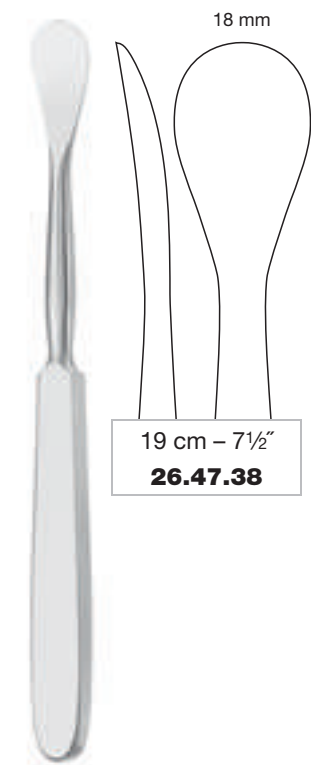

19 cm – 7½"  
**26.47.38**

**Sedillot**



Raspatorien  
Raspatories  
Legras  
Rugines  
Periostotomi

A10

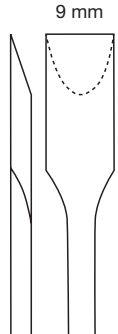

17 cm - 6¾"  
**26.48.01**

**Adson**



**Adson**



17 cm - 6¾"  
**26.48.03**



17 cm - 6¾"  
**26.48.04**



**Olivecrona**

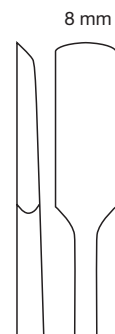

19 cm - 7½"  
**26.50.58**



**Farabeuf**

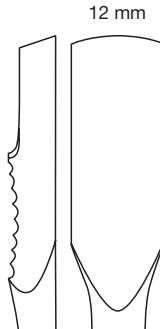

15 cm - 6"  
**26.53.13**

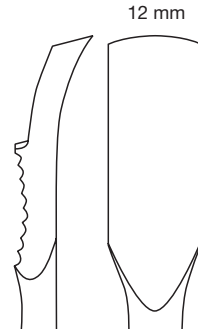

15 cm - 6"  
**26.53.23**



Raspatorien  
Raspatories  
Legras  
Rugines  
Periostotomi

A10



Lambotte

10 mm

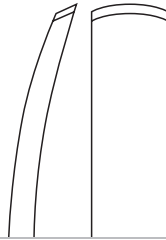

22 cm – 8<sup>3</sup>/<sub>4</sub>"  
**26.54.10**

15 mm



22 cm – 8<sup>3</sup>/<sub>4</sub>"  
**26.54.15**

20 mm

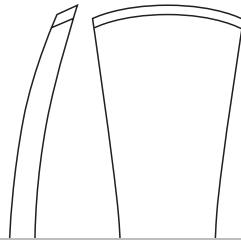

22 cm – 8<sup>3</sup>/<sub>4</sub>"  
**26.54.20**

25 mm

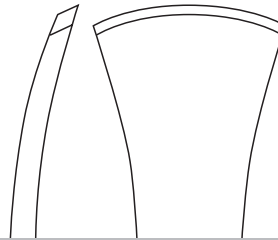

22 cm – 8<sup>3</sup>/<sub>4</sub>"  
**26.54.25**



Key

6 mm



18 cm – 7<sup>1</sup>/<sub>8</sub>"  
**26.56.06**

12 mm

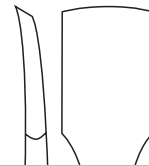

19 cm – 7<sup>1</sup>/<sub>2</sub>"  
**26.56.12**

20 mm

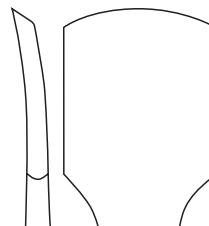

20 cm – 8"  
**26.56.20**

25 mm

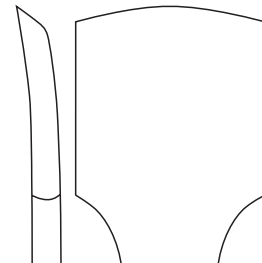

21 cm – 8<sup>1</sup>/<sub>4</sub>"  
**26.56.25**



**Raspatorien  
Raspatories  
Legras  
Rugines  
Periostotomi**

# A10

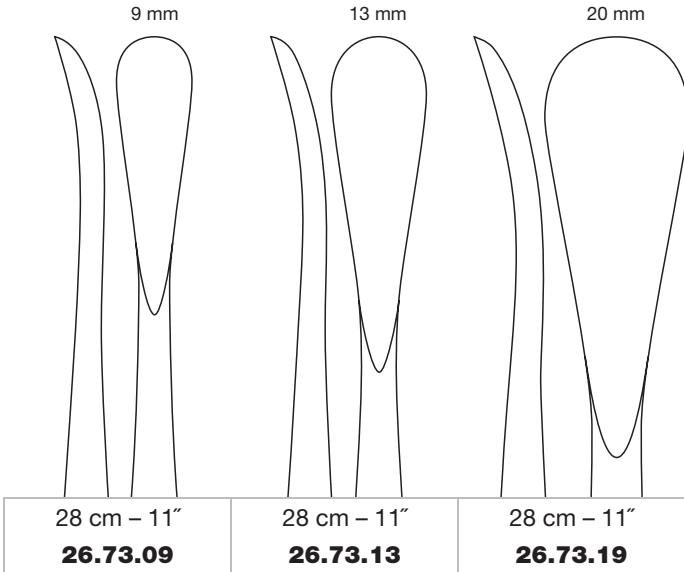

**Langenbeck**

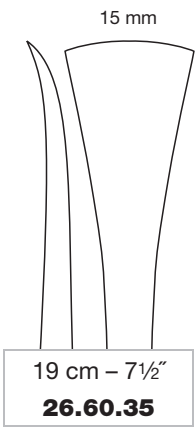

**Cushing**

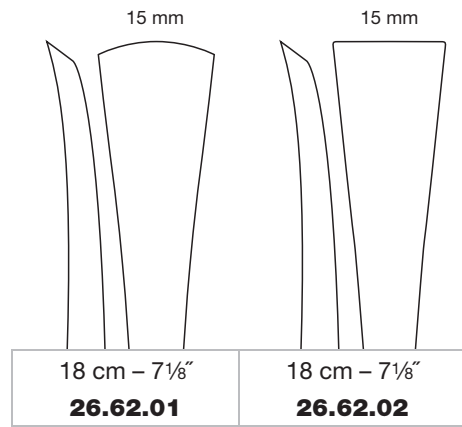



PROPYLUX

- ▶ Ein biokompatibler Kunststoff der neuesten Thermoplast-Generation
- ▶ Extrem formbeständig bei häufiger Autoklavierung
- ▶ A biocompatible plastic from the latest generation of thermoplastics
- ▶ Extremely high dimensional stability even when frequently autoclaved
- ▶ Un plástico biocompatible de la última generación de termoplásticos
- ▶ Extremadamente resistente a deformaciones en esterilizaciones en autoclave frecuentes
- ▶ Un plastique biocompatible de la toute dernière génération des thermoplastiques
- ▶ Extrêmement résistant aux déformations en cas de passages fréquents à l'autoclave
- ▶ Una plastica biocompatibile della più recente generazione di termoplastiche
- ▶ Estremamente resistente a deformazioni anche con trattamento frequente in autoclave



NOVOTEX

- ▶ Ein duroplastischer Kunststoff aus der Familie der Phenoplaste
- ▶ Sehr hart und bruchbeständig
- ▶ Thermosetting plastics of the range of phenol formaldehyde resins
- ▶ Very hard and break resistant
- ▶ Plástico termoendurecible de la familia de resina fenol-formaldehído
- ▶ Muy duro y resistente a la rotura
- ▶ Plastique thermodurcissable de la famille des résines phénol-formaldéhyde
- ▶ Très dur et résistant à la casse
- ▶ Materia plastica termoindurente della famiglia di resine fenoliche
- ▶ Molto duro e resistente alla rottura



3 mm

18,5 cm – 7¼"	<b>26.64.13P</b>	
	<b>26.64.13</b>	



6 mm

18,5 cm – 7¼"	<b>26.64.06P</b>	<b>26.64.16P</b>	<b>26.64.26P</b>	
	<b>26.64.06</b>	<b>26.64.16</b>	<b>26.64.26</b>	



Kunststoffgriff (autoklavierbar bis 134 °C bei 3 bar)  
 Plastic handle (autoclavable up to 134 °C at 3 bar)  
 Mango de plástico (autoclavable hasta 134 °C bajo presión de 3 bar)  
 Manche en plastique (autoclavable à 134 °C sous pression de 3 bars)  
 Manico di plastica (autoclavabile fino a 134 °C sotto pressione di 3 bar)



Raspatorien  
Raspatories  
Legras  
Rugines  
Periostotomi

A10

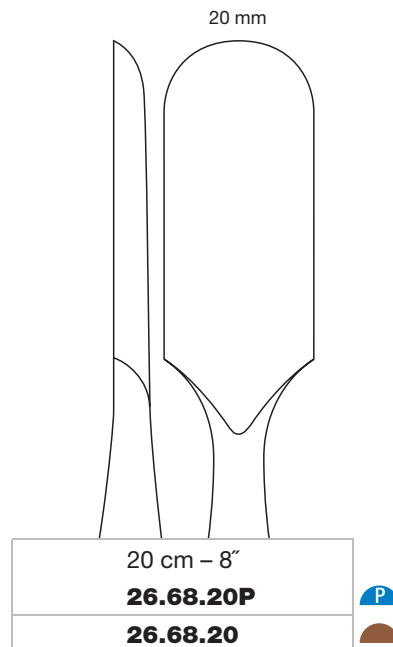
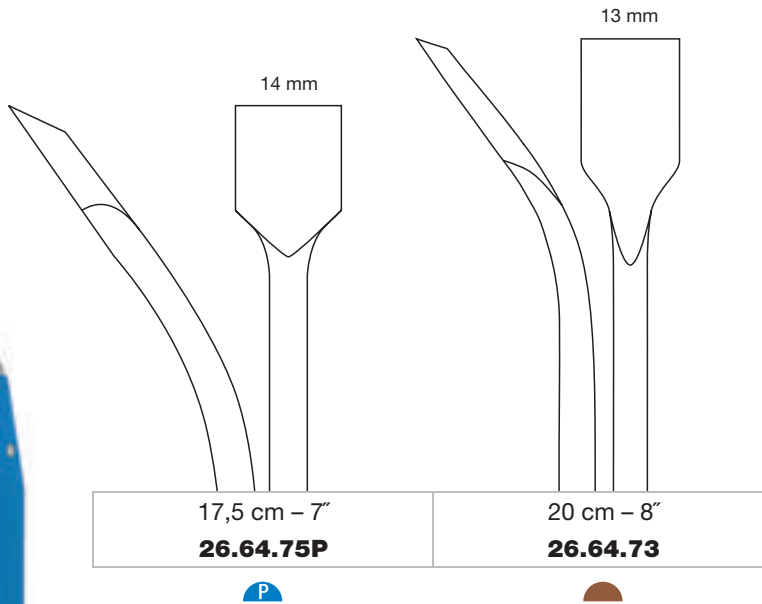



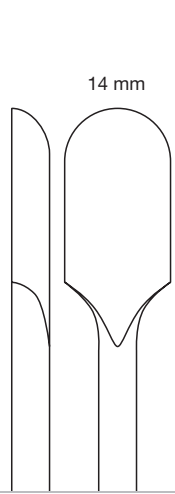

18,5 cm – 7 1/4"  
**26.64.86P**

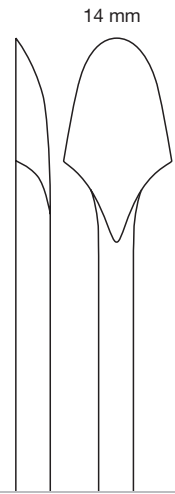

20 cm – 8"  
**26.64.84**

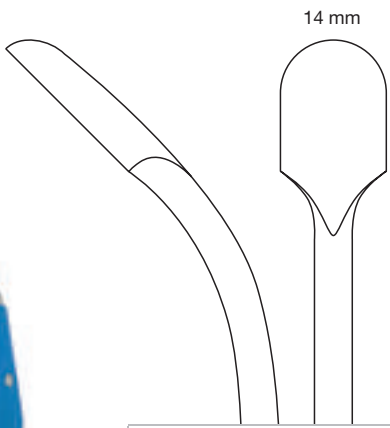

17,5 cm – 7"  
**26.64.96P**

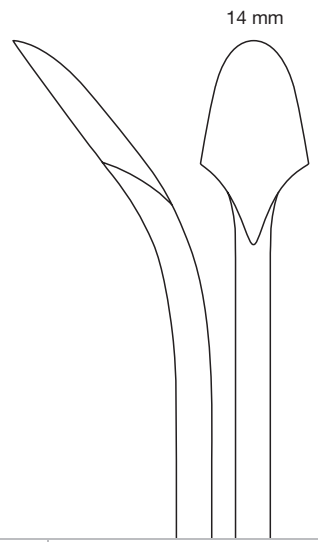

20 cm – 8"  
**26.64.94**



Kunststoffgriff (autoklavierbar bis 134 °C bei 3 bar)  
Plastic handle (autoclavable up to 134 °C at 3 bar)  
Mango de plástico (autoclavable hasta 134 °C bajo presión de 3 bars)  
Manche en plastique (autoclavable à 134 °C sous pression de 3 bars)  
Manico di plastica (autoclavabile fino a 134 °C sotto pressione di 3 bar)



**Raspatorien**  
**Raspatories**  
**Legras**  
**Rugines**  
**Periostotomi**

# A10



**Cobb**

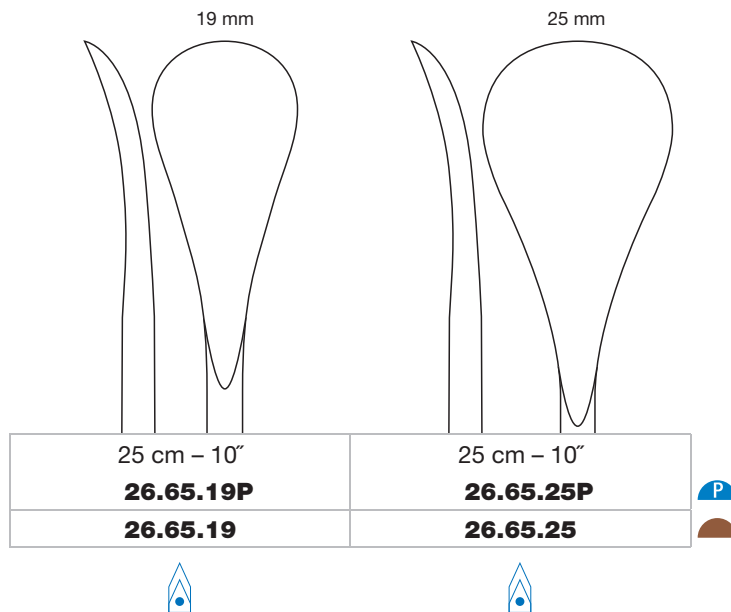
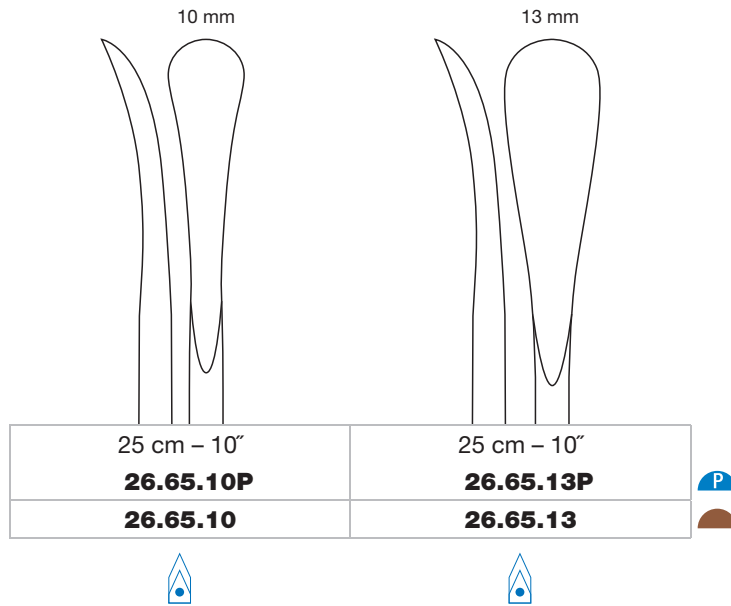



28 cm – 11"
<b>26.67.27P</b>
<b>26.67.27</b>

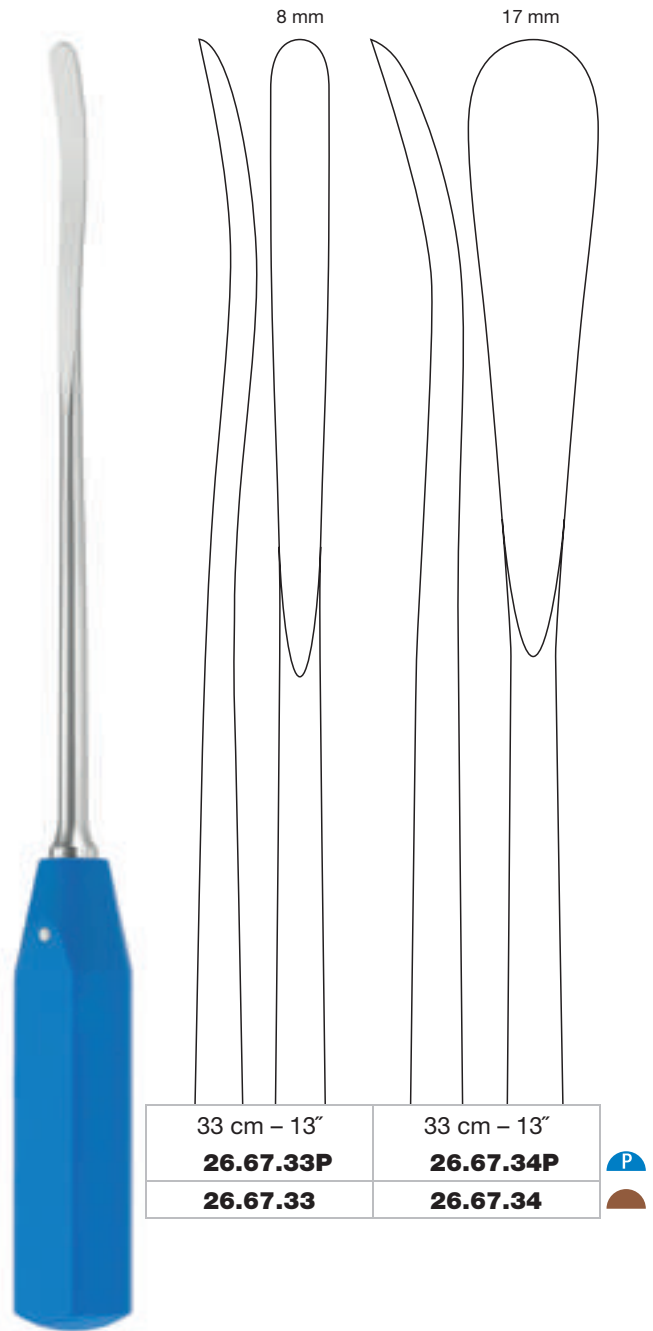

33 cm – 13"
<b>26.67.33P</b>
<b>26.67.33</b>

33 cm – 13"
<b>26.67.34P</b>
<b>26.67.34</b>



Wagner



Kunststoffgriff (autoklavierbar bis 134 °C bei 3 bar)  
Plastic handle (autoclavable up to 134 °C at 3 bar)  
Mango de plástico (autoclavable hasta 134 °C bajo presión de 3 bar)  
Manche en plastique (autoclavable à 134 °C sous pression de 3 bars)  
Manico di plastica (autoclavabile fino a 134 °C sotto pressione di 3 bar)

# www.medicon.de

Einen Überblick über das MEDICON-Gesamtprogramm finden Sie im Internet.

For general information on the complete MEDICON product range please refer to the Internet.

Una vista general de la gama completa de productos MEDICON puede encontrar en el Internet.

Pour une vue d'ensemble de la gamme complète des produits MEDICON nous vous prions de bien vouloir vous référer sur notre site Internet.

Una visione generale della completa gamma dei prodotti MEDICON la trovate nell'Internet.



**Hohlmeißelzangen**  
**Bone Rongeurs**  
**Pinzas gubias**  
**Pinces-gouges**  
**Pinze sgorbie**

**A11**

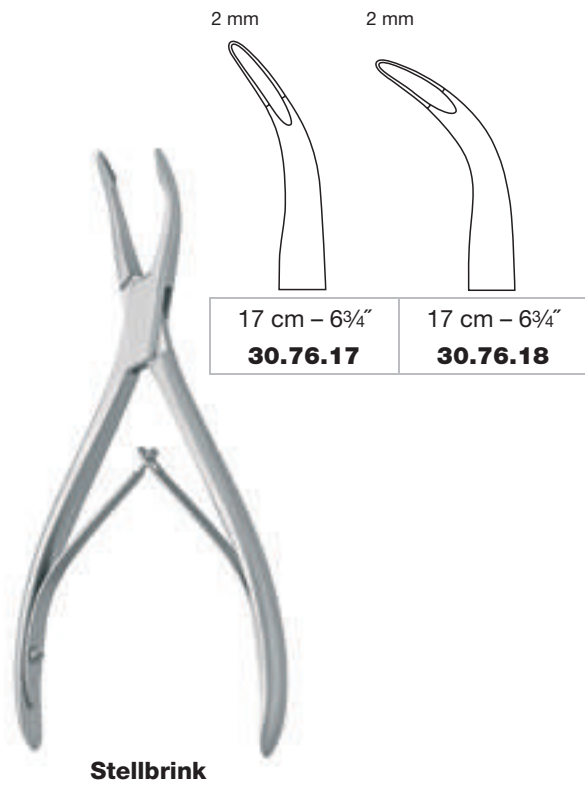
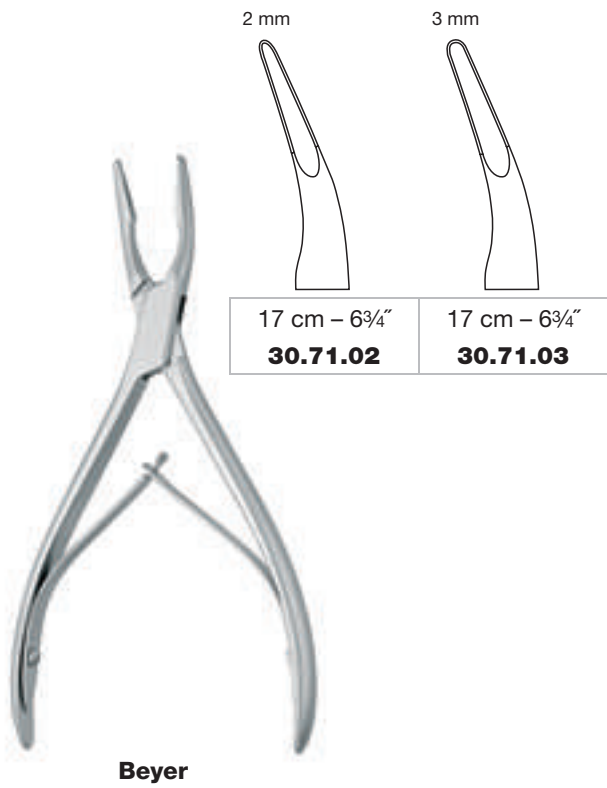
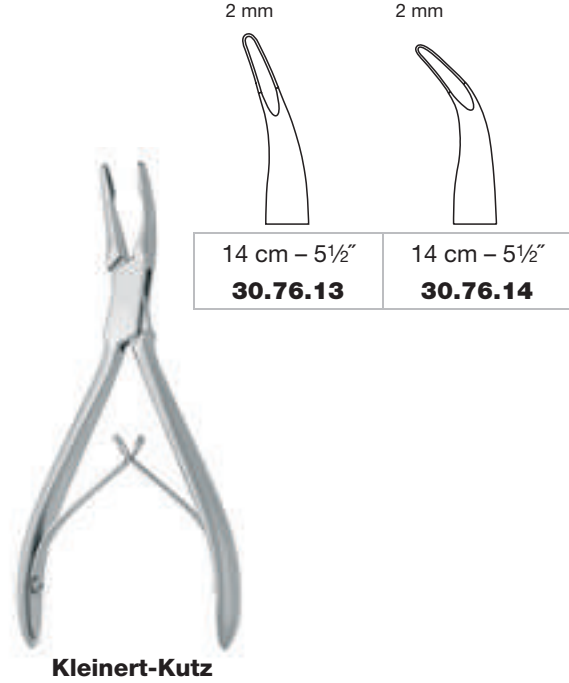
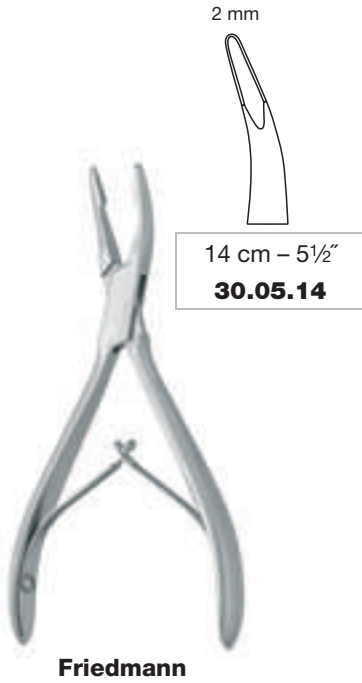



**Hohlmeißelzangen**  
**Bone Rongeurs**  
**Pinzas gubias**  
**Pinces-gouges**  
**Pinze sgorbie**

**A11**



7 mm

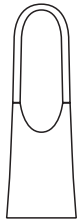

18 cm – 7 1/8"  
**30.52.17**

10 mm

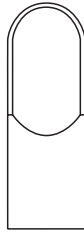

18 cm – 7 1/8"  
**30.52.18**

**Luer**



9 mm



18 cm – 7 1/8"  
**30.53.18**

**Luer**



4 mm

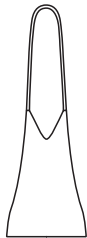

20 cm – 8"  
**30.54.70**

**Bacon**

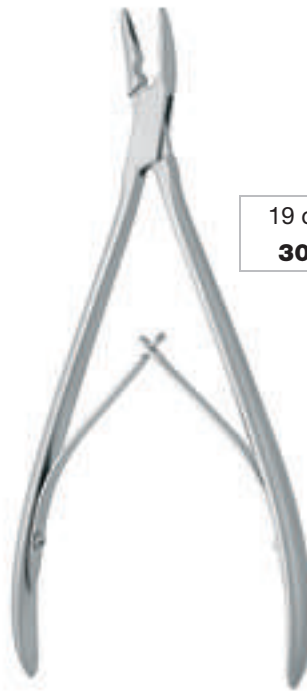

3 mm



19 cm – 7 1/2"  
**30.76.19**

3 mm



19 cm – 7 1/2"  
**30.76.29**





**Lempert**

**Hohlmeißelzangen**  
**Bone Rongeurs**  
**Pinzas gubias**  
**Pinces-gouges**  
**Pinze sgorbie**

**A11**





**Ruskin-Mini**

2 mm	3 mm	2 mm	3 mm
			
15 cm – 6" <b>31.04.02</b>	15 cm – 6" <b>31.04.03</b>	15 cm – 6" <b>31.05.02</b>	15 cm – 6" <b>31.05.03</b>



**Ruskin**

5 mm	5 mm
	
18 cm – 7 1/8" <b>31.06.05</b>	18 cm – 7 1/8" <b>31.07.05</b>



**Hohlmeißelzangen**  
**Bone Rongeurs**  
**Pinzas gubias**  
**Pinces-gouges**  
**Pinze sgorbie**

**A11**



**Smith-Petersen**

2 mm



24 cm - 9½"  
**31.09.03**

3 mm



24 cm - 9½"  
**31.09.13**

3 mm

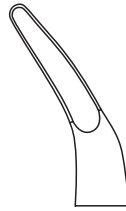

24 cm - 9½"  
**31.09.23**



**Ruskin**

5 mm



24 cm - 9½"  
**31.06.25**

5 mm



24 cm - 9½"  
**31.07.25**



**Hohlmeißelzangen**  
**Bone Rongeurs**  
**Pinzas gubias**  
**Pinces-gouges**  
**Pinze sgorbie**

**A11**

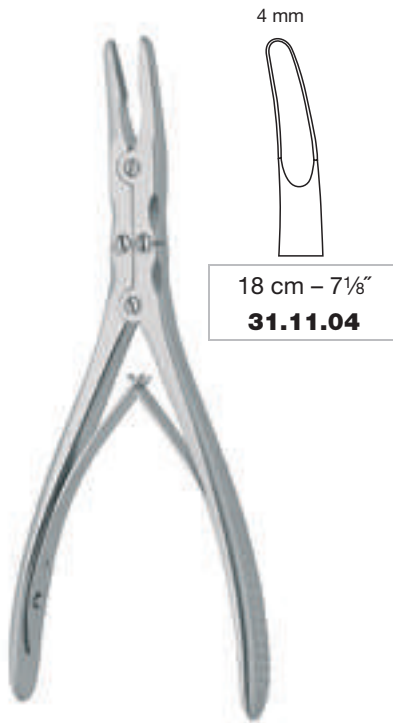

**Bayer**

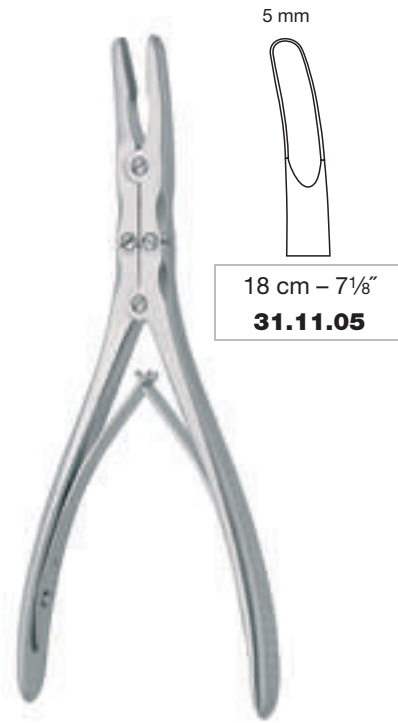

**Zaufal-Jansen**



**Marquardt**



**Hohlmeißelzangen**  
**Bone Rongeurs**  
**Pinzas gubias**  
**Pinces-gouges**  
**Pinze sgorbie**

**A11**



**Stille-Luer**

10 mm



23 cm - 9"  
**31.30.23**

17 mm

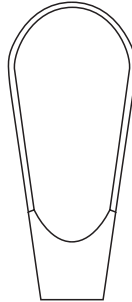

23 cm - 9"  
**31.30.24**

10 mm



23 cm - 9"  
**31.31.23**

17 mm

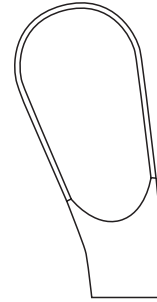

23 cm - 9"  
**31.31.24**

16 mm

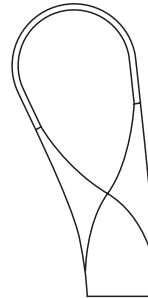

23 cm - 9"  
**31.31.53**

16 mm

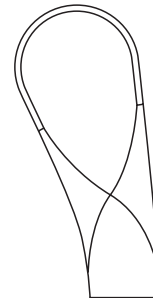

27 cm - 10 3/4"  
**31.31.57**



**Semb-Stille**

**Hohlmeißelzangen**  
**Bone Rongeurs**  
**Pinzas gubias**  
**Pinces-gouges**  
**Pinze sgorbie**

**A11**



**Leksell**

3 mm



23 cm - 9"  
**31.53.03**

5 mm

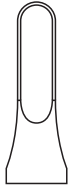

23 cm - 9"  
**31.53.05**

8 mm

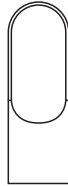

23 cm - 9"  
**31.53.08**



**Leksell**

5 mm

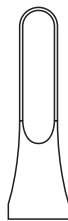

23 cm - 9"  
**31.51.05**

8 mm



23 cm - 9"  
**31.51.08**



**Hohlmeißelzangen**  
**Bone Rongeurs**  
**Pinzas gubias**  
**Pinces-gouges**  
**Pinze sgorbie**

**A11**



**Stille**

7 mm

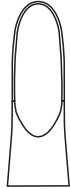

23 cm - 9"  
**31.31.83**

3 mm

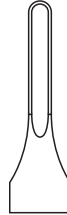

36 cm - 14 1/8"  
**31.54.03**

5 mm



36 cm - 14 1/8"  
**31.54.05**

8 mm



36 cm - 14 1/8"  
**31.54.08**



**Leksell**

**Hohlmeißelzangen und Knochensplitterzange**  
**Bone Rongeurs and Bone Cutting Forceps**  
**Pinzas gubias y pinza cortante para huesos**  
**Pinces-gouges et pince coupante à os**  
**Pinze sgorbie e pinza ossivora**

**A11**

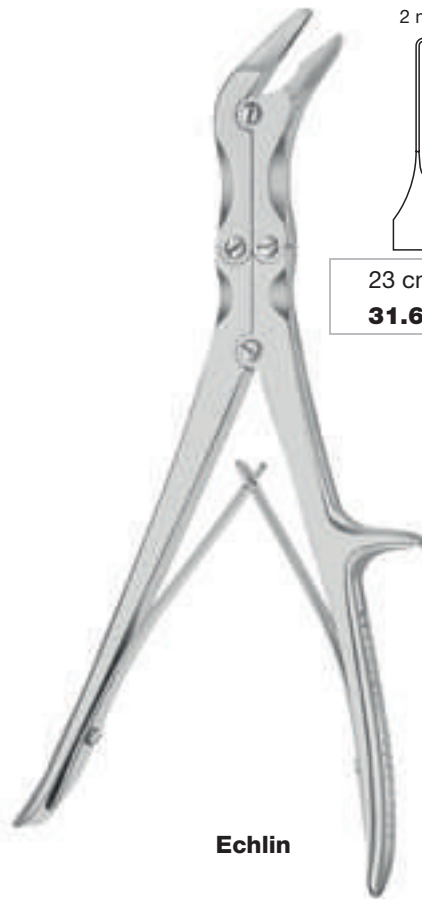

**Echlin**

2 mm



23 cm – 9"  
**31.61.02**

3 mm

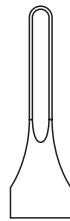

23 cm – 9"  
**31.61.03**

4 mm



23 cm – 9"  
**31.61.04**

Knochensplitterzange  
 Bone cutting forceps  
 Pinza cortante para huesos  
 Pince coupante à os  
 Pinza ossivora



**Liston-Key**

26 cm – 10¼"  
**33.75.27**



**Knochensplitterzangen**  
**Bone Cutting Forceps**  
**Pinzas cortantes para huesos**  
**Pinces coupantes à os**  
**Pinze ossivore**

**A11**



15 cm – 6"  
**33.02.15**

**Littauer-Liston**

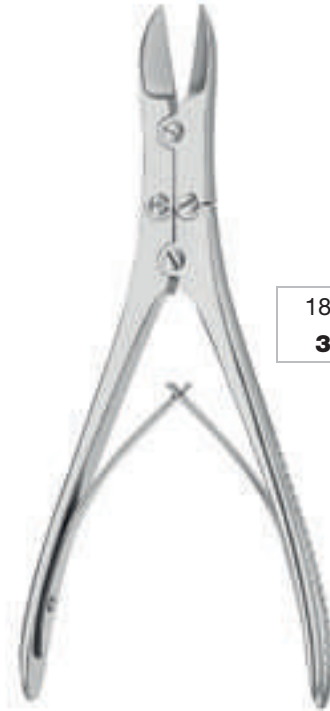

18 cm – 7 1/8"  
**33.56.18**



18 cm – 7 1/8"  
**33.57.18**

**Ruskin-Liston**



17 cm – 6 3/4"  
**33.59.17**

**McIndoe**



18 cm – 7 1/8"  
**33.58.18**



18 cm – 7 1/8"  
**33.59.18**

**McIndoe**



**Instrumente für die kraniale Neurochirurgie**  
**Instruments for Cranial Neurosurgery**  
**Instrumentos para neurocirugía craneal**  
**Instruments pour la neurochirurgie crânienne**  
**Strumenti per la neurochirurgia cranica**

**B**

**neuro**  
**CRANIALIS**

**Instrumente für die kraniale Neurochirurgie**  
**Instruments for Cranial Neurosurgery**  
**Instrumentos para neurocirugía craneal**  
**Instruments pour la neurochirurgie crânienne**  
**Strumenti per la neurochirurgia cranica**

<b>B01</b>	Kopfhaltungssysteme Head rest systems Sistemas de fijación craneal Systèmes de maintien crânien Sisteme di fissazione cranica	131
<b>B02</b>	Kopfhautklammern Scalp clips Clips hemostáticos para cuero cabelludo Clips hémostatiques pour cuir chevelu Clip emostatiche per cuoio capelluto	139
<b>B03</b>	Instrumente für die Trepanation und Kraniotomie Instruments for the trepanation and craniotomy Instrumentos para la trepanación y craneotomía Instruments pour la trépanation et craniotomie Strumenti per la trapanazione e craniotomia	143
<b>B04</b>	Stanzen Rongeurs Pinzas saca-bocadas Pinces emporte-pièce Laminotomi	153
<b>B05</b>	Haken und Dissektoren Hooks and dissectors Ganchos y disectores Crochets et dissecteurs Uncini e dissettori	165
<b>B06</b>	Diamantmesser und Mikro-Instrumente Diamond knives and micro instruments Cuchillos de diamante y micro instrumentos Couteau de diamant et micro-instruments Bisturi diamantati e strumenti micro	185
<b>B07</b>	Hirnspatel und Hirnspatelhalter Brain spatulas and brain spatula retractors Espátulas cerebrales y separadores para espátulas cerebrales Spatules cérébrales et ecarteurs pour des spatules cérébrales Spatole cerebrali e divaricatori cerebrali	199
<b>B08</b>	Zerebrovaskuläre Clips Cerebrovascular clips Clips cerebrovascular Clips vasculaires cérébraux Clip cerebrovascolari	207
<b>B09</b>	Neuro-Fixationssystem Neuro-fixation system Sistema para neuro-fijación Système de neuro-fixation Sistema di neuro-fissaggio	233
<b>B10</b>	Instrumente für die Hypophysektomie Instruments for hypophysectomy Instrumentos para la hipofisectomía Instruments pour l'hypophysectomie Strumenti per ipofisectomia	251
<b>B11</b>	Druckluftmotorensystem Pneumatic high speed system Sistema de motor neumático Système de moteur pneumatique Sistema motore pneumatico	265



Die Medicon Schädelklemmen wurden entsprechend den speziellen Anforderungen im OP entwickelt. In Verbindung mit der Grundeinheit bietet das innovative Kopfhaltungssystem ein Maximum an Sicherheit und Stabilität.

The Medicon head rests were developed to meet the special demands in the operating theatre. In combination with the basic unit this innovative head rest system offers a maximum of safety and stability.

Los fijadores craneal fueron concebidos de Medicon para responder a las exigencias especiales en los quirófanos. En combinación con la unidad básica el sistema innovador de fijación craneal presenta un máximo de seguridad y estabilidad.

Le système de maintien crânien de Medicon a été développé conformément aux demandes des chirurgiens. Notre système novateur de maintien crânien en combinaison avec l'unité de base offre le maximum de stabilité et de sécurité.

Il sistema di fissazione cranica è stato sviluppato in base alle esigenze specifiche della sala operatoria. Grazie all'unità di base, l'innovativo sistema di fissazione cranica offre maggior sicurezza e stabilità.

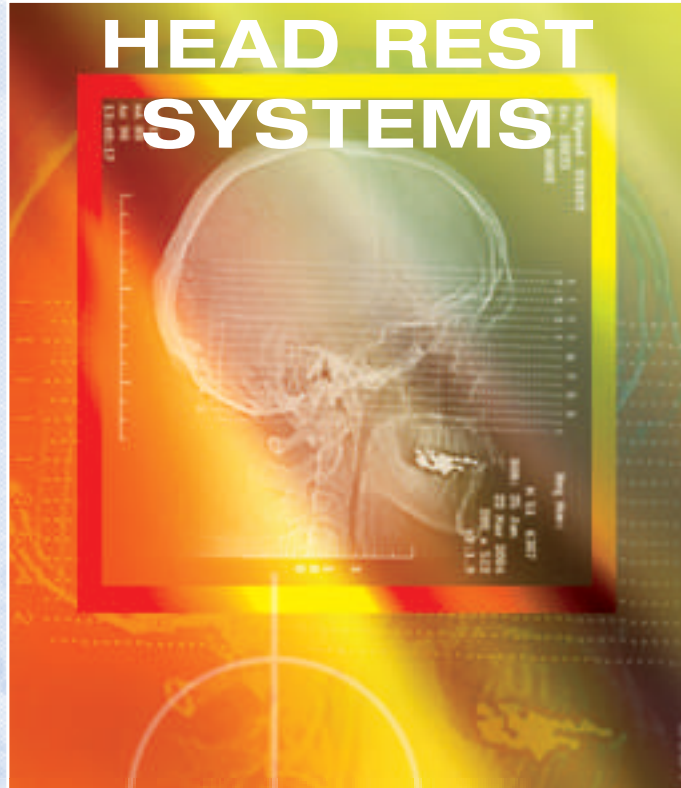

entwickelt in Zusammenarbeit mit:  
 developed in cooperation with:  
 desarrollado en colaboración con:  
 développée en collaboration avec:  
 sviluppato in collaborazione con:

**Prof. Dr. Sörensen**  
 Neurochirurgische Klinik, Würzburg



B01

# FiXiT

## HEAD REST SYSTEM

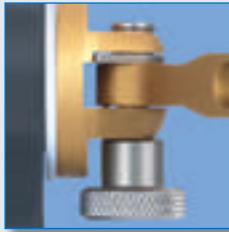

**Spielfreie Schraubverbindung**  
**Zero-backlash screw assembly**  
**Conexión de tornillo sin juego**  
**Assemblage vissé sans jeu**  
**Connessione a vite senza gioco**

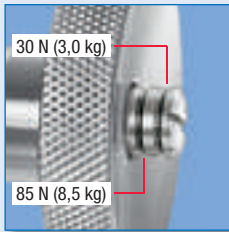

**Druckkraftanzeige**  
**Pressing power indicator**  
**Indicación de la fuerza de compresión**  
**Indicateur de la pression**  
**Indicatore della forza di compressione**



**Doppeltgesicherte Verriegelung**  
**Double-secured locking**  
**Cierre de doble seguridad**  
**Un seul verrouillage deux fois plus sûr**  
**Chiusura con doppia sicurezza**



**Verschleißfreier Gewindeinsatz**  
**Wear-resistant thread insert**  
**Inserto de rosca sin desgaste**  
**Filetage sans usure**  
**Inserto di filettatura non usurabile**

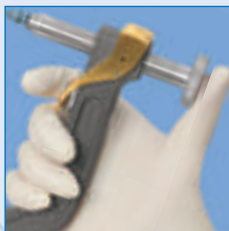

**Sehr gute Einhandbedienung**  
**Excellent one-hand operation**  
**Muy bueno con una sola mano**  
**Très bien d'une seule main**  
**Molto buona con una sola mano**

**Kopfhaltungssysteme**  
**Head Rest Systems**  
**Sistemas de fijación craneal**  
**Systèmes de maintien crânien**  
**Sisteme di fissazione cranica**

**B01**

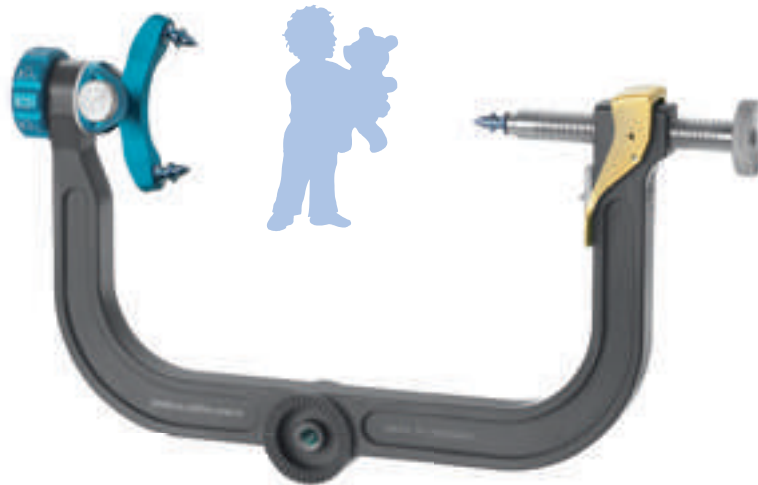

Satz (klein)  
 Set (small)  
 Juego (pequeño)  
 Jeu (petit)  
 Set (piccolo)

300 × 180 mm		<b>57.70.60</b>	
Satz bestehend aus:	<b>57.70.00</b> Head rest (small) with fixing screw	1x	
Set consisting of:	<b>57.70.12</b> Skull pin holder (87 mm)	1x	
Juego compuesto por:	<b>57.70.40</b> Skull pin (packing unit 5 pieces)	1x	
Jeu composé de:			
Set composto da:			

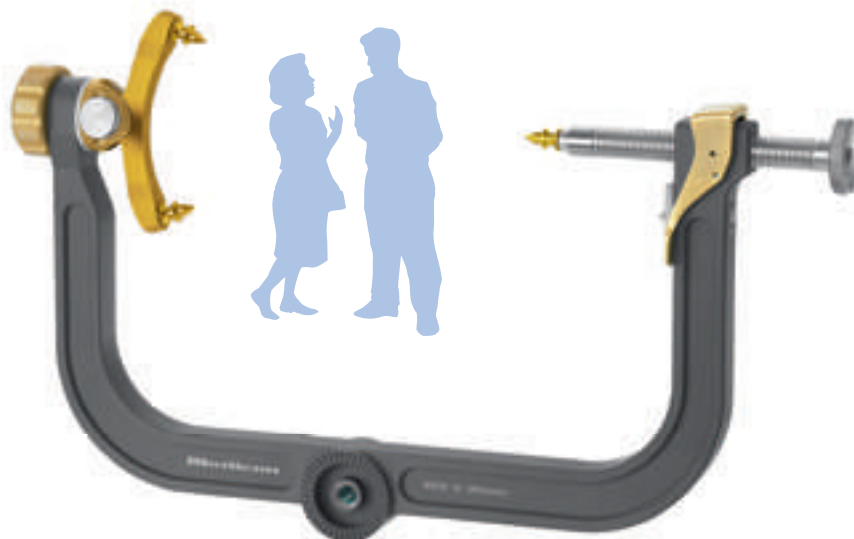

Satz (groß)  
 Set (large)  
 Juego (grande)  
 Jeu (grand)  
 Set (grande)

340 × 200 mm		<b>57.70.50</b>	
Satz bestehend aus:	<b>57.70.02</b> Head rest (small) with fixing screw	1x	
Set consisting of:	<b>57.70.16</b> Skull pin holder (105 mm)	1x	
Juego compuesto por:	<b>57.70.44</b> Skull pin (packing unit 5 pieces)	1x	
Jeu composé de:			
Set composto da:			

**B01**

**Kopfhaltungssystem (klein)**  
**Head Rest System (Small)**  
**Sistema de fijación craneal (pequeño)**  
**Système de maintien crânien (petit)**  
**Sistema di fissazione cranica (piccolo)**

Dornaufnahmen  
 Skull pin holders  
 Soportes para pernos  
 Porte-épines  
 Braccetti per punte

①	87 mm	<b>57.70.10</b>
②	87 mm	<b>57.70.12</b>
③	62 mm	<b>57.70.14</b>
④	67 mm	<b>57.70.20</b>
⑤	62 mm	<b>57.70.24</b>
⑥	37 mm	<b>57.70.30</b>
⑦	34 mm	<b>57.70.34</b>

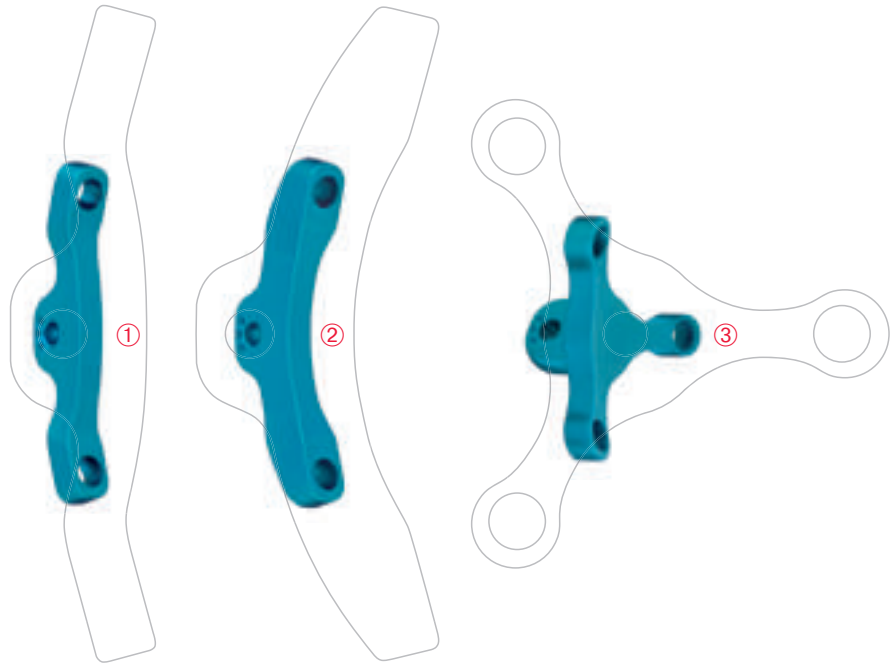

Schädelklemme (klein) mit Fixierschraube  
 Head rest (small) with fixing screw  
 Fijador craneal (pequeño) con tornillo de fijación  
 Maintien crânien (petit) avec vis de fixation  
 Testiera (piccolo) con vite di fissaggio

**Sörensen 57.70.00**

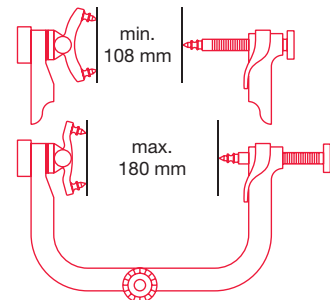

Fixierschraube  
 Fixing screw  
 Tornillo de fijación  
 Vis de fixation  
 vite di fissaggio



**40 mm 57.70.06**

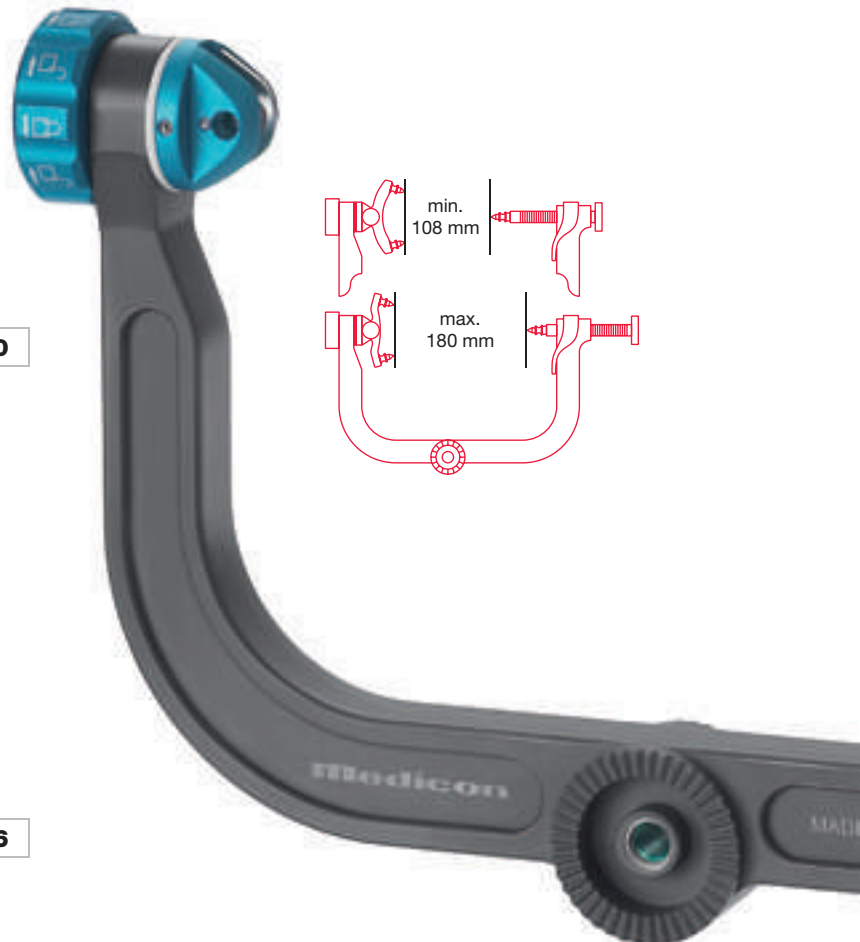

**Kopfhalterungssystem (klein)**  
**Head Rest System (Small)**  
**Sistema de fijación craneal (pequeño)**  
**Système de maintien crânien (petit)**  
**Sistema di fissazione cranica (piccolo)**

**B01**

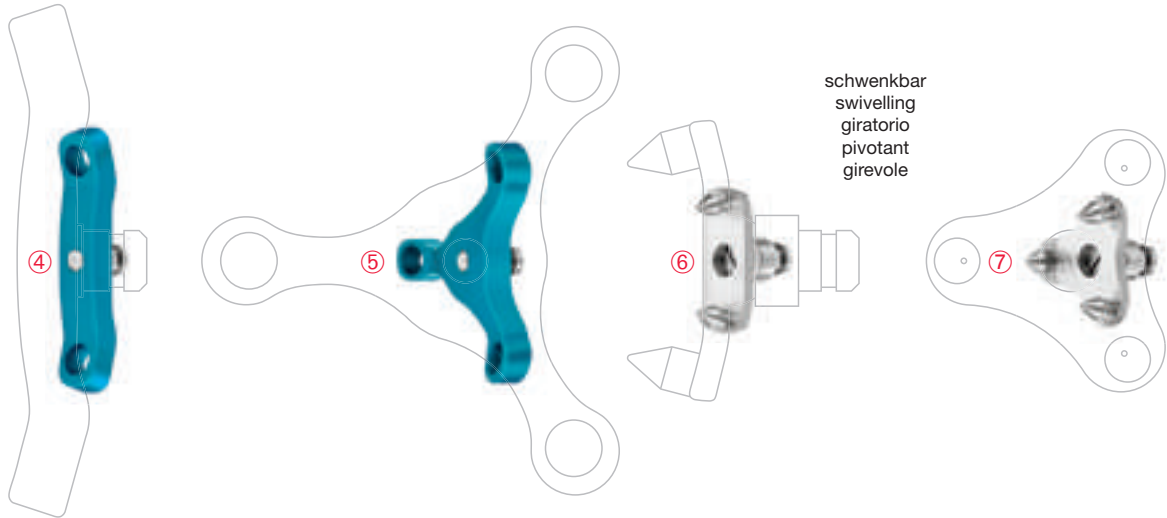

schwenkbar  
 swivelling  
 giratorio  
 pivotant  
 girevole



Dorne (wenig traumatisierend)  
 Skull pins (hardly traumatic)  
 Pernos (poco traumatica)  
 Epines (peu traumatisante)  
 Punte (minimamente traumatica)



25 mm **57.70.40** P<sub>5</sub> **Ti**



25 mm **57.70.42** P<sub>12x3</sub>

**STERILE**

Verpackungseinheit 12 Pack mit je 3 Stück, steril  
 Packing unit 12 packages of 3 pieces each, sterile  
 Caja con 12 paquetes incluyendo 3 piezas, estériles  
 Emballage de 12 paquets comportant chacun 3 pièce, stériles  
 Scatola da 12 confezioni da 3 pezzi, sterili

**B01**

**Kopfhaltungssystem (groß)**  
**Head Rest System (Large)**  
**Sistema de fijación craneal (grande)**  
**Système de maintien crânien (grand)**  
**Sistema di fissazione cranica (grande)**

Dornaufnahmen  
 Skull pin holders  
 Soportes para pernos  
 Porte-épines  
 Braccetti per punte

①	105 mm	<b>57.70.16</b>
②	105 mm	<b>57.70.18</b>

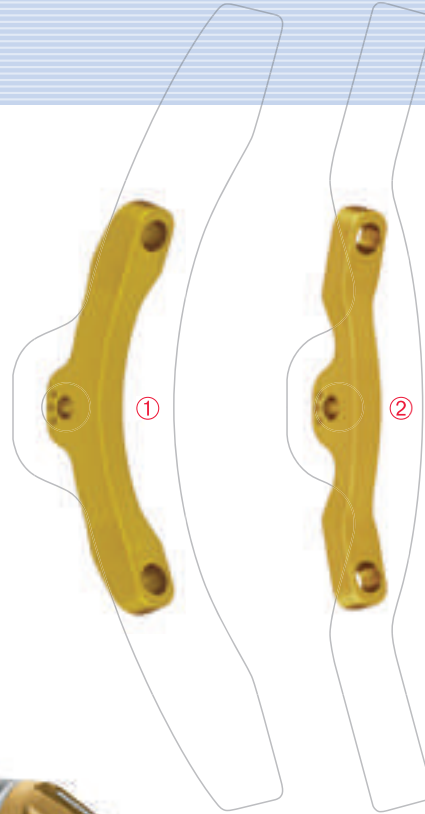

Schädelklemme (groß) mit Fixierschraube  
 Head rest (large) with fixing screw  
 Fijador craneal (grande) con tornillo de fijación  
 Maintien crânien (grand) avec vis de fixation  
 Testiera (grande) con vite di fissaggio

**Sörensen 57.70.02**

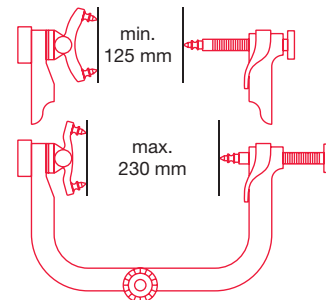

Fixierschraube  
 Fixing screw  
 Tornillo de fijación  
 Vis de fixation  
 Vite di fissaggio



**40 mm 57.70.06**

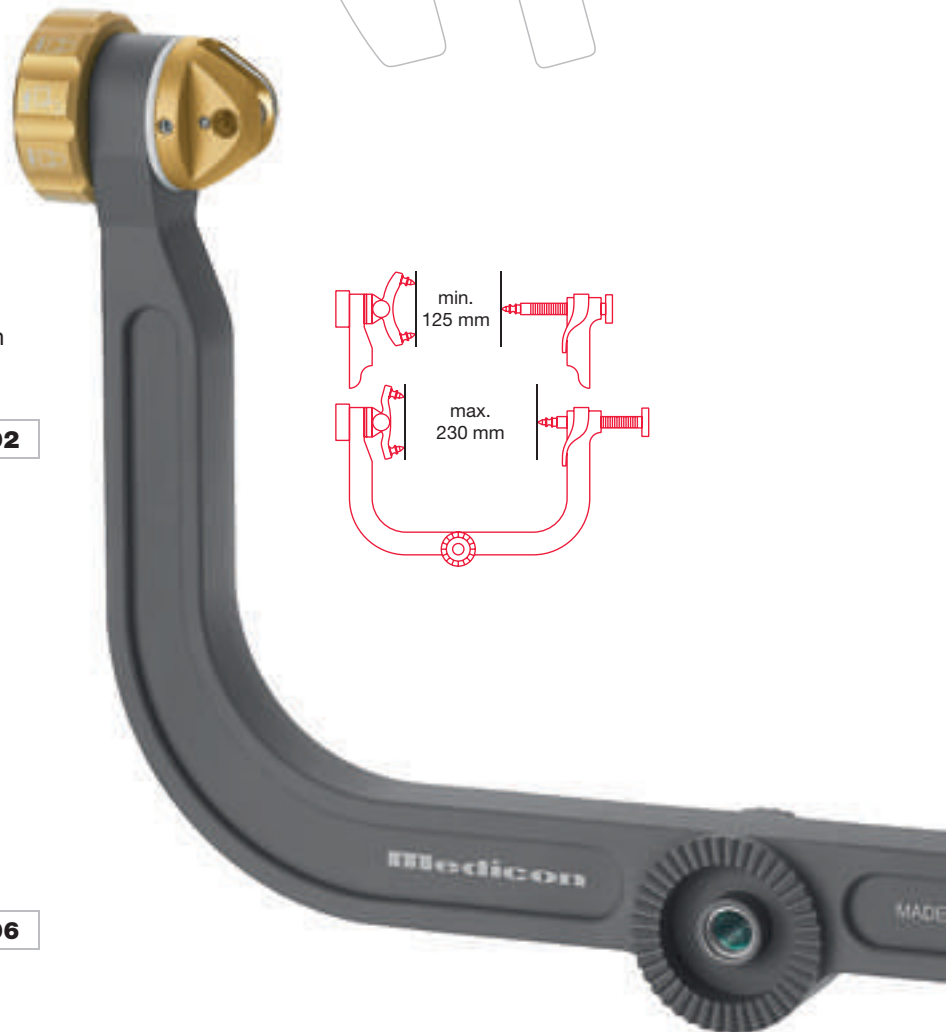

**Kopfhalterungssystem (groß)**  
**Head Rest System (Large)**  
**Sistema de fijación craneal (grande)**  
**Système de maintien crânien (grand)**  
**Sistema di fissazione cranica (grande)**

**B01**



1:1



25 mm **57.70.44** P<sub>5</sub> **Ti**

Dorne (wenig traumatisierend)  
 Skull pins (hardly traumatic)  
 Pernos (poco traumatica)  
 Epines (peu traumatisante)  
 Punte (minimamente traumatica)

1:1



25 mm **57.70.46** P<sub>12x3</sub>

**STERILE**

Verpackungseinheit 12 Pack mit je 3 Stück, steril  
 Packing unit 12 packages of 3 pieces each, sterile  
 Caja con 12 paquetes incluyendo 3 piezas, estériles  
 Emballage de 12 paquets comportant chacun 3 pièce, stériles  
 Scatola da 12 confezioni da 3 pezzi, sterili



IN GERMANY

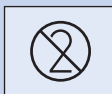

Einmalprodukt  
 Single use product  
 Prodotto para un solo uso  
 Produit à usage unique  
 Prodotto monouso

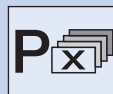

Verpackungseinheit "X" Stück  
 Packing unit "X" pieces  
 Paquete de "X" unidades  
 Emballage de "X" pièces  
 Confezione da "X" pezzi



Titan  
 Titanium  
 Titanio  
 Titane  
 Titanio

**B01**

**Adapter für Grundeinheit**  
**Connectors for Basic Unit**  
**Adaptadors per unidad básica**  
**Adaptateurs pour unité de base**  
**Adattatori per unità di base**

Verbindungsadapter  
 Connector for adaption  
 Adaptador per conexión  
 Adaptateur pour connexion  
 Adattatore per raccordo

zur Adaption der Schädelklemme mit der Grundeinheit  
 to connect head rest to basic unit  
 para la conexión del cabezal con el unidad básica  
 pour connexion du maintien crânien avec unité de base  
 per il raccordo della testiera con l'unità di base

**57.70.65**

Universaladapter  
 Universal connector  
 Adaptador universal  
 Adaptateur universel  
 Adattatore universale

zur Adaption der Schädelklemme mit der Grundeinheit und weiterem operativen Zubehör

to connect head rest to basic unit as well as to further operative accessories

para la conexión del cabezal con el unidad básica y más accesorios operativos

pour connexion du maintien crânien avec unité de base et accessoires supplémentaires

adattatore universale per il raccordo della testiera con l'unità di base e ulteriori accessori

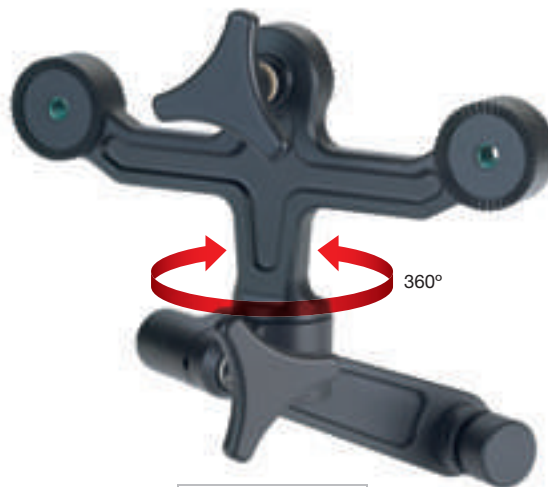
**57.70.66****451.02.17**

Unser komplettes FIXIT-Programm finden Sie in unserem Sonderprospekt.  
 For our complete line of FIXIT, see our special brochure.  
 El programa completo de FIXIT se encuentra en nuestro folleto especial.  
 Vous trouverez notre programme complet de FIXIT dans notre brochure spécial.  
 Troverete il nostro programma completo di FIXIT nel nostro depliant speciale.



**Kopfhautklammern**  
**Scalp Clips**  
**Clips hemostáticos para cuero cabelludo**  
**Clips hémostatiques pour cuir chevelu**  
**Clip emostatiche per cuoio capelluto**

**B02**

- Biokompatibles Material ◀
- Atraumatische Verzahnung ◀
- Zuverlässige Blutstillung ◀
  
- Biocompatible material ◀
- Atraumatic dovetailing ◀
- Reliable hemostasis ◀
  
- Material biocompatible ◀
- Dentado atraumático ◀
- Hemostasis fiable ◀
  
- Matériel biocompatible ◀
- Denture atraumatique ◀
- L'hémostase éprouvée ◀
  
- Materiale biocompatibile ◀
- Dentellatura atraumatica ◀
- Emostasi affidabile ◀



**B02****Kopfhautklammer und Zange****Scalp Clip and Forceps****Clip hemostático para cuero cabelludo y pinza****Clip hémostatique pour cuir chevelu et pince****Clip emostatiche per cuoio capelluto e pinza**SCALP CLIPS  
**RANEY**  
*shark*

Kopfhautklammer aus Kunststoff

Plastic scalp clip

Clip hemostático de plástico para cuero cabelludo

Clip hémostatique en plastique pour cuir chevelu

Clip emostatiche in plastica per cuoio capelluto

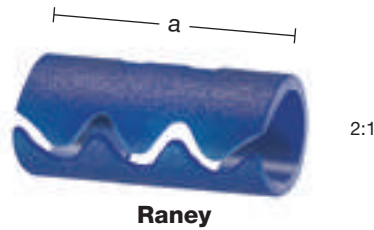
**Raney**

a = 16 mm

**57.85.03A**P<sub>[20x10]</sub>**STERILE**

Anlege- und Entnahmezange

Applying and removing forceps

Pinza para aplicar y quitar

Pince à appliquer et retirer

Pinza per applicare e togliere

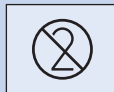
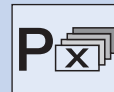

16 cm - 6 1/4"

**57.85.07**Einmalprodukt  
Single use product  
Producto para un solo uso  
Produit à usage unique  
Prodotto monousoVerpackungseinheit "X" Stück  
Packing unit "X" pieces  
Paquete de "X" unidades  
Emballage de "X" pièces  
Confezione da "X" pezzi

**Kopfhautklammer und Zange**  
**Scalp Clip and Forceps**  
**Clip hemostático para cuero cabelludo y pinza**  
**Clip hémostatique pour cuir chevelu et pince**  
**Clip emostatiche per cuoio capelluto e pinza**

**B02**

Kopfhautklammer aus Stahl  
 Steel scalp clip  
 Clip hemostático de acero para cuero cabelludo  
 Clip hémostatique en acier pour cuir chevelu  
 Clip emostatiche in acciaio per cuoio capelluto

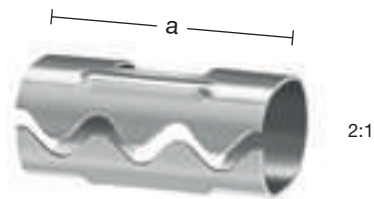

**Raney**

a = 16 mm

**57.85.01**



Anlege- und Entnahmezange  
 Applying and removing forceps  
 Pinza para aplicar y quitar  
 Pince à appliquer et retirer  
 Pinza per applicare e togliere



16 cm - 6 1/4"

**57.85.05**



Verpackungseinheit "X" Stück  
 Packing unit "X" pieces  
 Paquete de "X" unidades  
 Emballage de "X" pièces  
 Confezione da "X" pezzi

**B02****Galeahaken und Kopfhautklammer****Galea Hooks and Scalp Clip****Ganchos para galea y clip hemostático para cuero cabelludo****Crochets de galea et clip hémostatique pour cuir chevelu****Uncini per galea e clip emostatica per cuoio capelluto**

Galeahaken  
Galea hooks  
Ganchos para galea  
Crochets de galea  
Uncini per galea

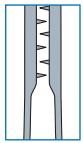
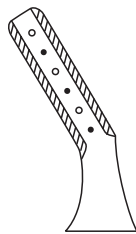
**Yasargil**

31 cm – 12 1/8"  
**57.85.10**

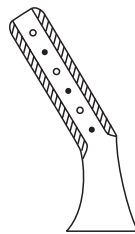

41 cm – 16"  
**57.85.11**

Kopfhautklammer aus Stahl

Steel scalp clip

Clip hemostático de acero para cuero cabelludo

Clip hémostatique en acier pour cuir chevelu

Clip emostatica in acciaio per cuoio capelluto

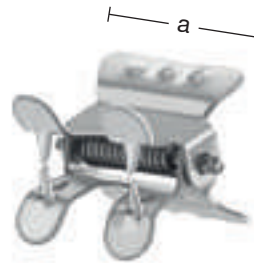

2:1

**Mod. Köln**

a = 10 mm

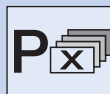
**57.85.50**

**Instrumente für die Trepanation und Kraniotomie**  
**Instruments for the Trepanation and Craniotomy**  
**Instrumentos para la trepanación y craneotomía**  
**Instruments pour la trépanation et craniotomie**  
**Strumenti per la trapanazione e craniotomia**

**B03**

Trepanationen können bereits um 10.000 v. Chr. nachgewiesen werden. In Südamerika wurden mehrere Gräber (etwa 2000 Jahre alt) mit trepanierten Schädeln und chirurgischen Werkzeugen gefunden.

There is evidence of trepanations as early as 10,000 BC. Several graves (around 2000 years old) with trepanned skulls and surgical instruments were found in South America.

Existen pruebas de que ya se realizaban trepanaciones por el año 10.000 a. de C. En Sudamérica se han encontrado varias tumbas (de alrededor de 2000 años de antigüedad) con cráneos trepanados y herramientas quirúrgicas.

On retrouve des traces de trépanation dès 10 000 av.J.C. environ. Plusieurs tombes (vieilles d'environ 2 000 ans) contenant des crânes trépanés et des instruments chirurgicaux ont été retrouvées en Amérique du Sud.

Già dal 10.000 a.C. si hanno dimostrazioni di trapanazioni. In Sudamerica sono state ritrovate tombe (di circa 2000 anni fa) con crani trapanati e strumenti chirurgici.

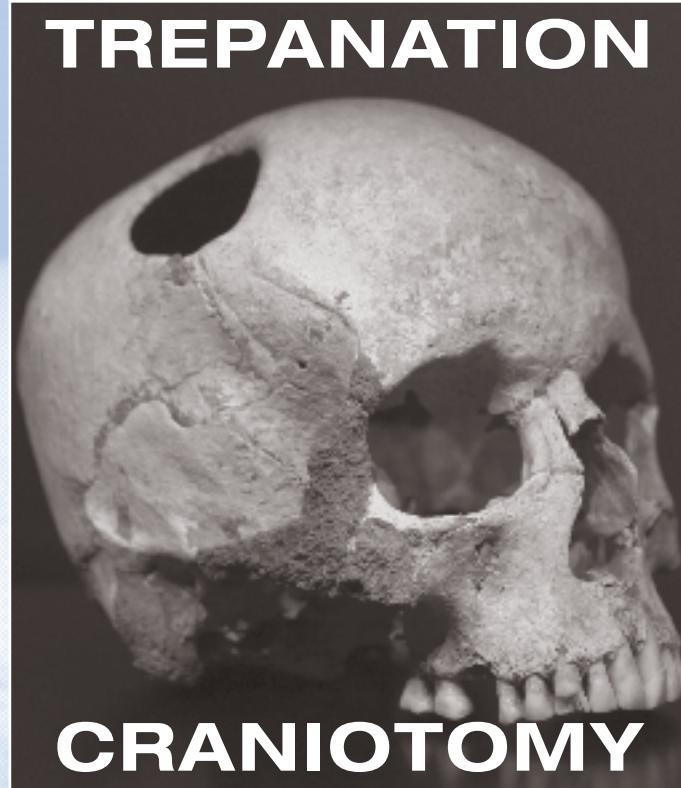

**Vip Air**  
PNEUMATIC HIGH SPEED SYSTEM

**B03**

**Druckluftmotoren**  
**Pneumatic High Speed Motors**  
**Motores neumáticos**  
**Moteurs pneumatiques**  
**Motori pneumatici**

**VipAir**  
 PNEUMATIC HIGH SPEED SYSTEM

Winkelmotor  
 Angled motor  
 Motor angulado  
 Moteur angulaire  
 Motore angolato

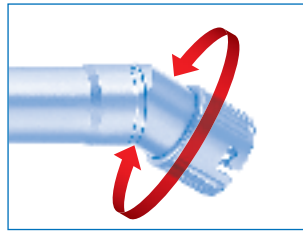

Das drehbare Winkelstück verhindert ein Verwinden des Motorschlauches  
 The rotatable elbow avoids a torsion of the motor tube  
 La pieza de mano giratoria evita una torsión del tubo de motor  
 Le coude à plat pivotant empêche une torsion du tuyau moteur  
 Il raccordo girevole impedisce una torsione del tubo motore



11 cm - 4 $\frac{3}{8}$ " **93.00.20**

entsichert  
 unlocked  
 desasegurado  
 déverrouillé  
 sbloccare

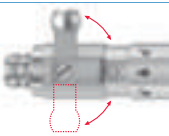

gesichert  
 locked  
 asegurado  
 verrouillé  
 bloccare



Sicherungsriegel der Kupplung  
 Safety lock of coupling  
 Pasador de seguridad del acoplamiento  
 Embrayage à verrou de sécurité  
 Chiusura di sicurezza dell'accoppiamento

Trepanmotor  
 Trepan motor  
 Motor de trépano  
 Moteur à trépan  
 Motore trapano



15,5 cm - 6 $\frac{1}{8}$ " **93.00.25**

Mit niedriger Drehzahl, hohem Drehmoment und HUDSON-Anschluß  
 With low speed, high torque and HUDSON connection  
 Con un número de revoluciones bajo, un momento de giro alto y conexión HUDSON  
 Avec régime faible, rotation rapide et raccord HUDSON  
 Con a basso numero di giri, elevato momento torcente ed attacco HUDSON

Technische Daten Technical data Especificaciones técnicas Caractéristiques techniques Dati tecnici	Drehzahl bei 8 bar Revolutions per minute at 8 bar Número de revoluciones a 8 bar Nombre de tours à 8 bar Numero di giri a 8 bar	Drehmoment bei 8 bar Torque at 8 bar Momento de giro a 8 bar Moment de rotation à 8 bar Momento torcente a 8 bar	Leistung bei 8 bar Output at 8 bar Potencia a 8 bar Puissance à 8 bar Potenza a 8 bar	Empfohlener Druck Recommended pressure Presión recomendada Pression recommandée Pressione raccomandata	Freigegebener Druck Approved pressure Presión permitida Pression libérée Pressione permessa
<b>93.00.20</b>	100.000 U/min	2,8 Ncm	60 Watt	6-8 bar	8±2 bar
<b>93.00.25</b>	950 U/min	45,0 Ncm	88 Watt	8 bar	8±2 bar

Kraniotome  
 Craniotomes  
 Cráneotomos  
 Crâniotomes  
 Craniotomi



1:1

a = 10 mm	a = 15 mm	a = 20 mm
<b>S</b>	<b>M</b>	<b>L</b>
<b>93.00.30</b>	<b>93.00.32</b>	<b>93.00.34</b>

Kraniotomfräser  
 Craniotome burrs  
 Fresas para craneotomo  
 Fraises pour crâniotome  
 Frese per craniotomo

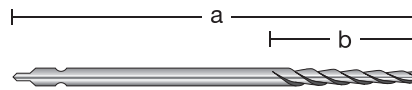

1:1

**STERILE**

Ø 1,5 mm	Ø 1,5 mm	Ø 1,5 mm
a = 48 mm	a = 52 mm	a = 66 mm
b = 12 mm	b = 16 mm	b = 20 mm
<b>S</b>	<b>M</b>	<b>L</b>
<b>93.01.15</b>	<b>93.03.37</b>	<b>93.03.38</b>

Trepanfräser  
 Trepanation burrs  
 Fresas de trépano  
 Fraises à trépan  
 Punta per perforatore



HUDSON-Anschluß  
 HUDSON connection  
 Conexión HUDSON  
 Raccord HUDSON  
 Attacco HUDSON

1:1

mit Montageschlüssel  
 with mounting wrench  
 con llave de ensamblaje  
 avec clé de montage  
 con chiave di assemblaggio

a = Ø 7 mm	a = Ø 11 mm	a = Ø 16 mm
<b>93.04.00</b>	<b>93.04.05</b>	<b>93.04.10</b>



# VipAir

PNEUMATIC HIGH SPEED SYSTEM

Das komplette Druckluftmotorensystem finden sie auf den Seiten 265-276.  
 The complete pneumatic high speed system can be found on pages 265-276.  
 El sistema completo de motor neumático se describe en las páginas 265-276.  
 Vous trouverez le système de moteur à air comprimé complet aux pages 265-276.  
 Il sistema completo di motore pneumatico si trova alle pagine 265-276.



**Schädelstanzen**  
**Skull Punches**  
**Pinzas saca-bocadas para craneotomía**  
**Pinces emporte-pièce crâniennes**  
**Pinze per craniotomia**

**B03**



mit 2 Blättern  
 with 2 blades  
 con 2 hojas  
 avec 2 lames  
 con 2 lame

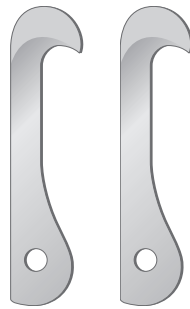

21 cm – 8¼"  
**57.01.20**

**Dahlgren**

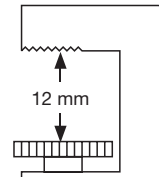
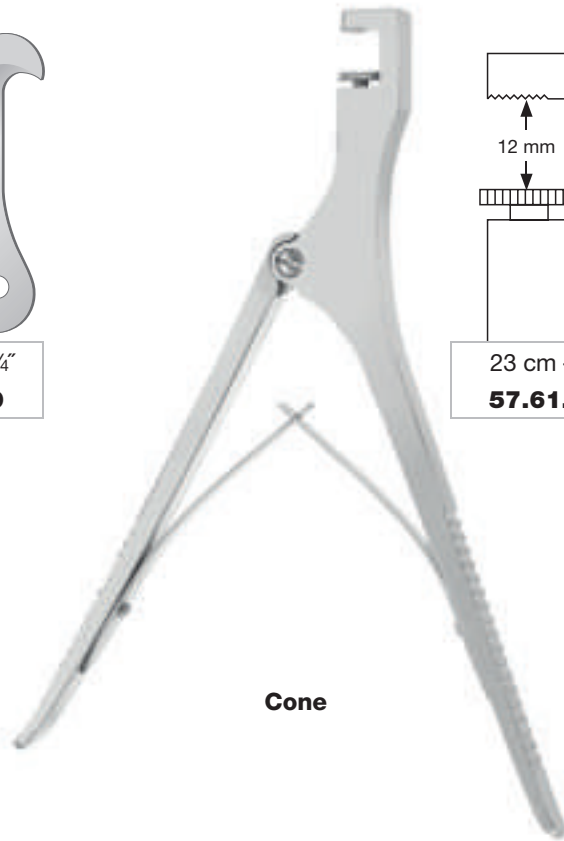

23 cm – 9"  
**57.61.11**

**Cone**



mit 2 Blättern  
 with 2 blades  
 con 2 hojas  
 avec 2 lames  
 con 2 lame

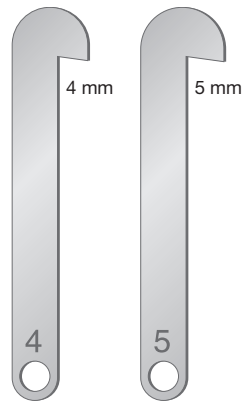

21 cm – 8¼"  
**57.01.21**

**DeVilbiss**



**Schädeltrephinen und Bohrerführungszange**  
**Skull Trephines and Drill Guide Forceps**  
**Trépanos craneales y pinza guía de taladros**  
**Tréphines crâniennes et pince guide-forêt**  
**Trapano cranico e pinza guida-perforatore**

**B03**

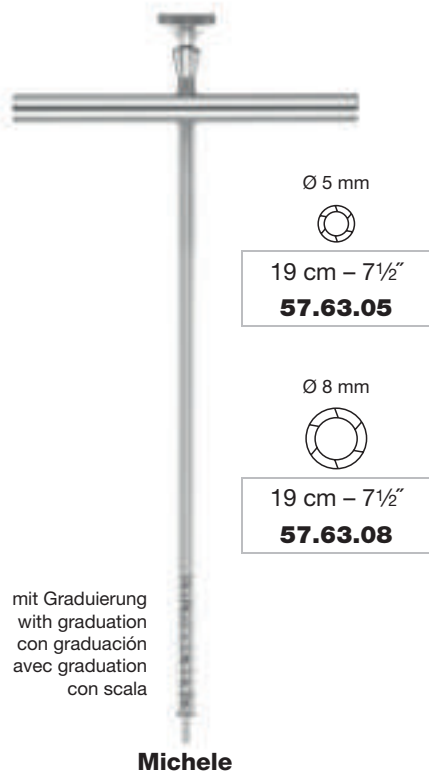

Bohrerführungszange  
 Drill guide forceps  
 Pinza guía de taladros  
 Pince guide-forêt  
 Pinza guida-perforatore

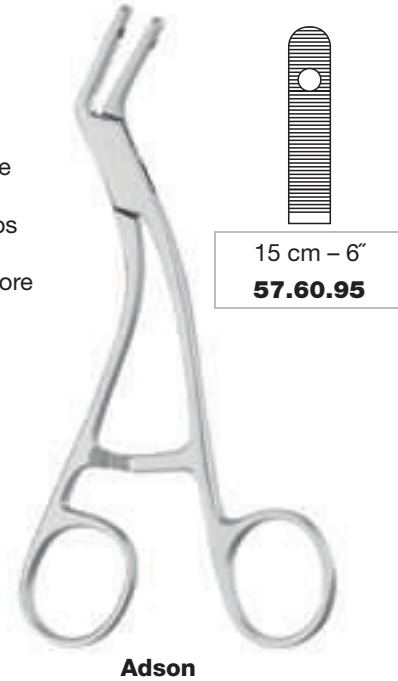

mit verstellbarem Dorn und abnehmbarem Quergriff  
 with adjustable centering point and detachable cross-bar handle  
 con guía-central ajustable y mango transversal desmontable  
 avec pointe ajustable et manche transversal démontable  
 con punta regolibile e manico trasversale smontabile

Ø 13 mm

Ø 16 mm

Ø 19 mm

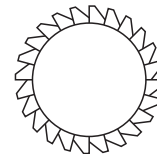
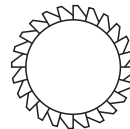
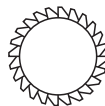

11 cm – 4¾”

11 cm – 4¾”

11 cm – 4¾”

**57.63.13**

**57.63.16**

**57.63.19**

**B03**

**Drahtsägen und Zubehör**  
**Wire Saws and Accessories**  
**Sierras de hilo de acero y accesorios**  
**Scies en fil d'acier et accessoires**  
**Seghe di filo d'acciaio e accessori**

Drahtsägen  
 Wire saws  
 Sierras de hilo de acero  
 Scies en fil d'acier  
 Seghe di filo d'acciaio

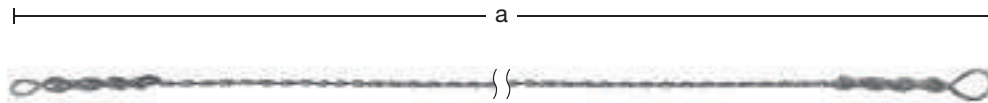

1:1

**Gigli (Olivecrona)**

Ø 1 mm	<b>57.64.30</b>	a = 300 mm
Ø 1 mm	<b>57.64.40</b>	a = 400 mm
Ø 1 mm	<b>57.64.50</b>	a = 500 mm
Ø 1 mm	<b>57.64.60</b>	a = 600 mm
Ø 1 mm	<b>57.64.70</b>	a = 700 mm

Handgriffe  
 Handle  
 Mango  
 Manche  
 Manico

**Gigli**

**57.64.02**

**Gigli**

**57.64.06**

Einführungsinstrument (flexibel)  
 Guiding instrument (flexible)  
 Instrumento para la introducción (flexible)  
 Instrument à introduire (flexible)  
 Strumento introduttore (flessibile)

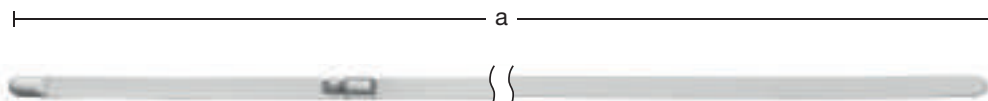
**De Martel (Bailey)**

6 mm	<b>57.64.90</b>	a = 330 mm
------	-----------------	------------

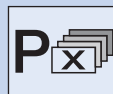

**Schädelhalter**  
**Skull Traction Tongs**  
**Pinzas craneales de tracción**  
**Pinces de traction crâne**  
**Pinze di trazione per cranio**

**B03**



**Crutchfield**

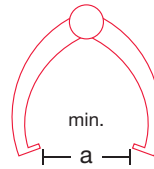

min.

a

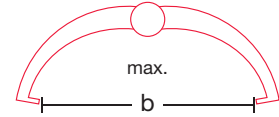

max.

b

a = 65 mm	<b>57.67.01</b>	b = 115 mm
a = 90 mm	<b>57.67.02</b>	b = 180 mm

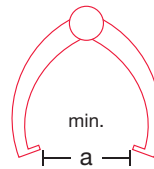

min.

a

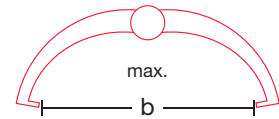

max.

b

a = 30 mm	<b>57.68.02</b>	b = 155 mm
-----------	-----------------	------------

Satz bestehend aus: Set consisting of: Juego compuesto por: Jeu composé de: Set composto da:	<b>57.68.12</b> Wrench	1x
	<b>57.68.13</b> Skull pins	2x

Dorn  
Skull pin  
Perno  
Epine  
Punta



**57.68.12**

Schlüssel  
Wrenches  
Llaves  
Clés  
Chiave



**57.68.13**



**Handbohrapparat und Werkzeuge**  
**Hand Drill and Tools**  
**Perforador de mano y terminales**  
**Perforateur à main et outils**  
**Trapano a mano e punte**

**B03**

Bogenkurbel  
 Brace  
 Berbiqui  
 Vilebrequin  
 Manovella

27,5 cm – 10<sup>3</sup>/<sub>4</sub>”  
**57.60.03**

Verlängerungsstück  
 Extension piece  
 Pieza de prolongación  
 Rallonge  
 Pezzo di prolungamento

9 cm – 3<sup>1</sup>/<sub>2</sub>”  
**57.60.05**

**Hudson****Hudson****57.60.00**

Satz bestehend aus:  
 Set consisting of:  
 Juego compuesto por:  
 Jeu composé de:  
 Set composto da:

<b>57.60.03</b>	Hand drill	1x
<b>57.60.05</b>	Extension piece	1x
<b>57.60.09</b>	Burr	1x
<b>57.60.14</b>	Burr	1x
<b>57.60.16</b>	Dust burr	1x
<b>57.60.22</b>	Dust burr	1x

Flachbohrer  
 Flat drill  
 Broca plano  
 Fraise en plat  
 Perforatore piatto



**Cushing 57.60.34** Ø 14 mm

Fräser  
 Burrs  
 Fresas  
 Fraises  
 Frese



**57.60.09** Ø 9 mm



**57.60.14** Ø 14 mm

Kugelfräser  
 Spherical burrs  
 Fresas redondas  
 Fraises forme boule  
 Frese a pallina



**57.60.16** Ø 16 mm



**57.60.22** Ø 22 mm

Perforationsbohrer  
 Perforators  
 Brocas helicoidales  
 Fraises hélicoïdales  
 Perforatori elicoidali



**McKenzie 57.60.43** Ø 13 mm



**D'Errico 57.60.76** Ø 16 mm

**Handbohrapparate und Werkzeuge**  
**Hand Drills and Tools**  
**Perforadores de mano y terminales**  
**Perforateurs à main et outils**  
**Trapani a mano e punte**

**B03**

Spiralbohrer  
 Twist drills  
 Brocas espirales  
 Fraises en spirale  
 Perforatori a spirale

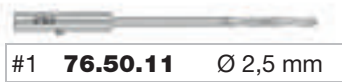

Trephine  
 Trephine  
 Trépano  
 Tréphine  
 Trapano

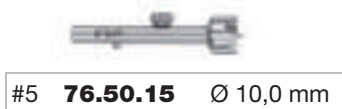

Fräser  
 Burrs  
 Fresas  
 Fraises  
 Frese



Satz komplett  
 Set complete  
 Juego completo  
 Jeu complet  
 Set completo

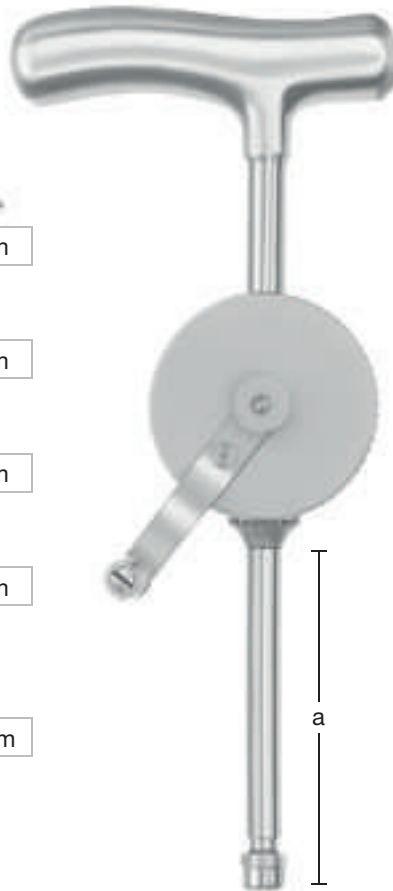
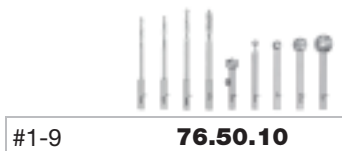

Handbohrapparate (allein)  
 Hand drills (only)  
 Perforadores de mano (solo)  
 Perforateurs à main (seul)  
 Trapani a mano (solo)

Stille	
<b>76.50.01</b>	a = 50 mm
Stille-Sherman	
<b>76.50.31</b>	a = 100 mm

Vorbohrer  
 Reamer  
 Perforador  
 Alésoir  
 Perforatore



Stille	76.50.00	
	<b>76.50.01</b> Hand drill (a = 50 mm)	1x
	<b>76.50.11</b> Twist drill	1x
	<b>76.50.12</b> Twist drill	1x
	<b>76.50.13</b> Twist drill	1x
Satz bestehend aus: Set consisting of: Juego compuesto por: Jeu composé de: Set composto da:	<b>76.50.14</b> Twist drill	1x
	<b>76.50.15</b> Trephine	1x
	<b>76.50.16</b> Burr	1x
	<b>76.50.17</b> Burr	1x
	<b>76.50.18</b> Burr	1x
	<b>76.50.19</b> Burr	1x

Stille-Sherman	76.50.30	
Satz bestehend aus: Set consisting of: Juego compuesto por: Jeu composé de: Set composto da:	<b>76.50.31</b> Hand drill (a = 100 mm)	1x
	<b>76.50.11</b> Twist drill	1x
	<b>76.50.12</b> Twist drill	1x
	<b>76.50.13</b> Twist drill	1x



**Handbohrapparate und Spiralbohrer**  
**Hand Drills and Twist Drills**  
**Perforadores de mano y brocas espirales**  
**Perforateurs à main et forets hélicoïdaux**  
**Trapani a mano e perforatori elicoidali**

**B03**

mit verstellbarem Griff, Dreibackenspannfutter und Schlüssel  
 with adjustable handle, three-jaw chuck and wrench  
 con mango ajustable, porta-brocas de trimandibular y llave  
 avec manche ajustable, mandrin trois mâchoires et clé  
 con manico regolabile, mandrino a tre ganasce e chiave

**76.50.80**

Schlüssel  
 Wrench  
 Llave  
 Clé  
 Chiave

**76.50.81**

mit Dreibackenspannfutter und Schlüssel  
 with three-jaw chuck and wrench  
 con porta-brocas de trimandibular y llave  
 avec mandrin trois mâchoires et clé  
 con mandrino a tre ganasce e chiave

**76.51.20**

Schlüssel  
 Wrench  
 Llave  
 Clé  
 Chiave

**76.51.21****Ralk**

Spiralbohrer  
 Twist drills  
 Brocas espirales  
 Forets hélicoïdaux  
 Perforatori elicoidali

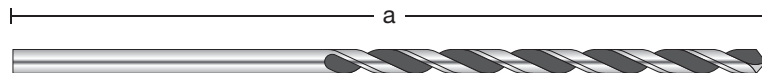

1:1

Ø 1,5 mm	<b>76.69.15</b>	a = 7,0 cm
Ø 2,0 mm	<b>76.69.20</b>	a = 8,5 cm
Ø 2,5 mm	<b>76.69.25</b>	a = 9,5 cm
Ø 3,0 mm	<b>76.69.30</b>	a = 10,0 cm
Ø 3,2 mm	<b>76.69.32</b>	a = 10,0 cm

Ø 3,5 mm	<b>76.69.35</b>	a = 11,0 cm
Ø 4,0 mm	<b>76.69.40</b>	a = 12,0 cm
Ø 4,5 mm	<b>76.69.45</b>	a = 13,0 cm
Ø 5,0 mm	<b>76.69.50</b>	a = 13,0 cm
Ø 6,0 mm	<b>76.69.60</b>	a = 14,0 cm

**Stanzen**  
**Rongeurs**  
**Pinzas saca-bocadas**  
**Pinces emporte-pièce**  
**Laminotomi**

**B04**

Flacher Schieber ◀  
 Ergonomisches Design und Balance ◀  
 Einteilige Zerlegetechnik ◀

Flat upper slide ◀  
 Ergonomic design and balance ◀  
 One piece dismantable rongeur ◀

Corredera plana ◀  
 Diseño ergonómico e equilibrado ◀  
 Pinza saca-bocada desmontable de  
 una sola pieza

Coulisse plate ◀  
 Design et équilibre ergonomiques ◀  
 Technique de démontage en une pièce ◀

Asta piatta ◀  
 Design ed equilibrio ergonomici ◀  
 Tecnica di smontaggio mono pezzo ◀



Kerrison  
 ...DieBLAUEN.



B04

# Kerrison ...DieBLAUEN.

**Zerlegbare Stanzen mit Silikon Griff**  
**Dismantable Rongeurs with Silicone Handle**  
**Pinzas saca-bocadas desmontables con mango de silicona**  
**Pinces emporte-pièce démontables avec manche en silicone**  
**Laminotomi smontabili con manico in silicone**

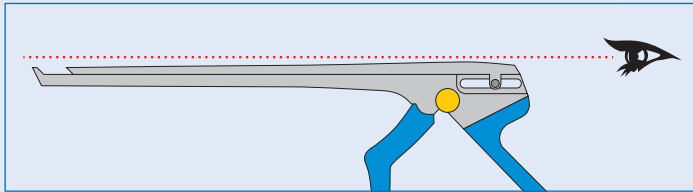
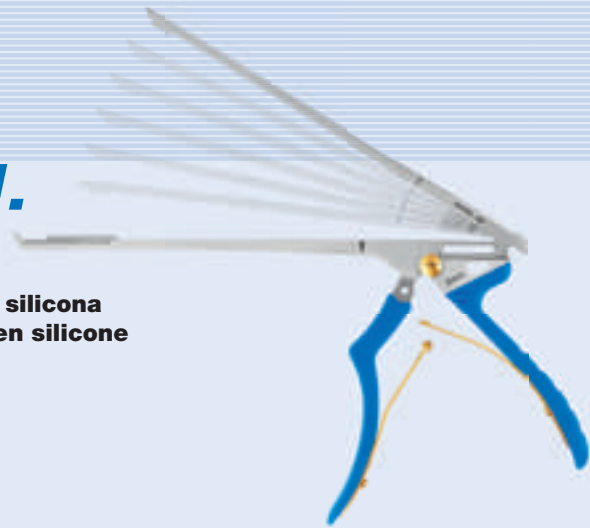

**Flacher Schieber für optimale Sicht bei minimal-invasiven Eingriffen**  
**Flat upper slide allows ideal visibility for minimally invasive surgery**  
**Corredera plana posibilita una visión óptimal en intervenciones minimamente invasivas**  
**Coulisse plate pour une visibilité optimale lors des interventions minimales invasives**  
**L'asta piatta permette una vista ottimale per interventi mini-invasivi**



**Ergonomisches Design und Balance für höchste Präzision und Arbeitskomfort**  
**Ergonomic design and balance for high precision and working comfort**  
**Diseño ergonómico e equilibrado para la máxima precisión y confort de trabajo**  
**Design et équilibre ergonomique pour une précision et un confort de travail maximal**  
**Design ed equilibrio ergonomici per un'altissima precisione e confort di lavorativo**

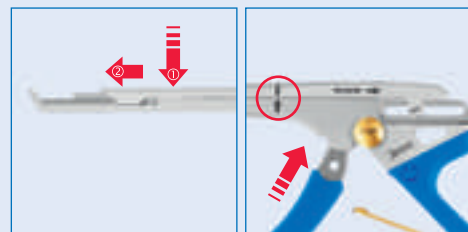
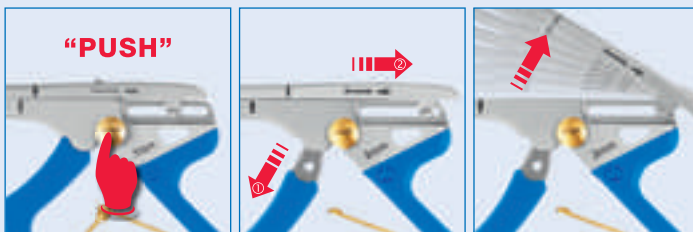

**Einteilige Zerlegetechnik für einfache Demontage und Montage**  
**One piece dismantable rongeur for easy disassembling and assembling**  
**Pinza saca-bocada desmontable de una sola pieza para un desmontaje/montaje sencillo**  
**Technique de démontage d'une pièce pour un montage et un démontage facile**  
**Tecnica di smontaggio monopezzo per un smontaggio e montaggio facile**



Kerrison  
...DieBLAUEN.

**Zerlegbare Stanzen mit Silikongriff**  
**Dismantable Rongeurs with Silicone Handle**  
**Pinzas saca-bocadas desmontables con mango de silicona**  
**Pinces emporte-pièce démontables avec manche en silicone**  
**Laminotomi smontabili con manico in silicone**

**B04**



— b —

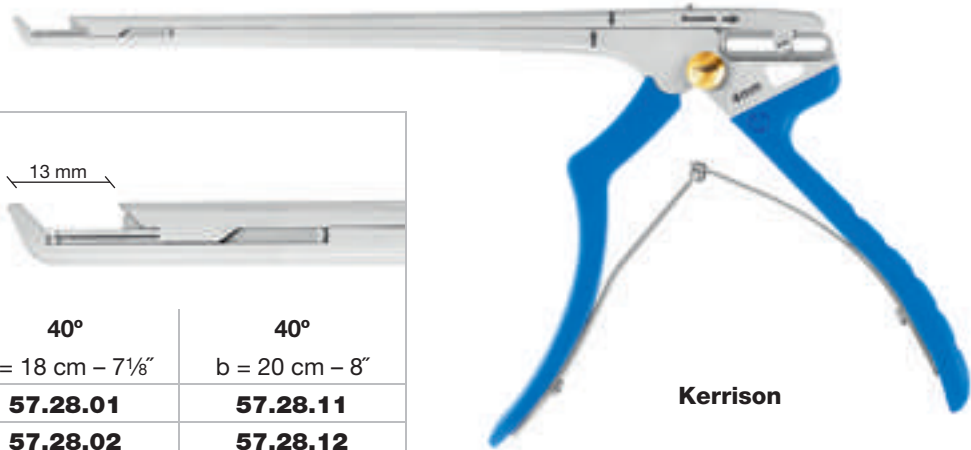

Stanzbreite Jaw width Ancho del corte Largeur des mors Larghezza de morso	D	
	40°	40°
a	b = 18 cm – 7 1/8"	b = 20 cm – 8"
1 mm	<b>57.28.01</b>	<b>57.28.11</b>
2 mm	<b>57.28.02</b>	<b>57.28.12</b>
3 mm	<b>57.28.03</b>	<b>57.28.13</b>
4 mm	<b>57.28.04</b>	<b>57.28.14</b>
5 mm	<b>57.28.05</b>	<b>57.28.15</b>
6 mm	<b>57.28.06</b>	<b>57.28.16</b>

Kerrison



mit Auswerfer  
with ejector  
con espulsor  
avec éjecteur  
con espulsore



— b —

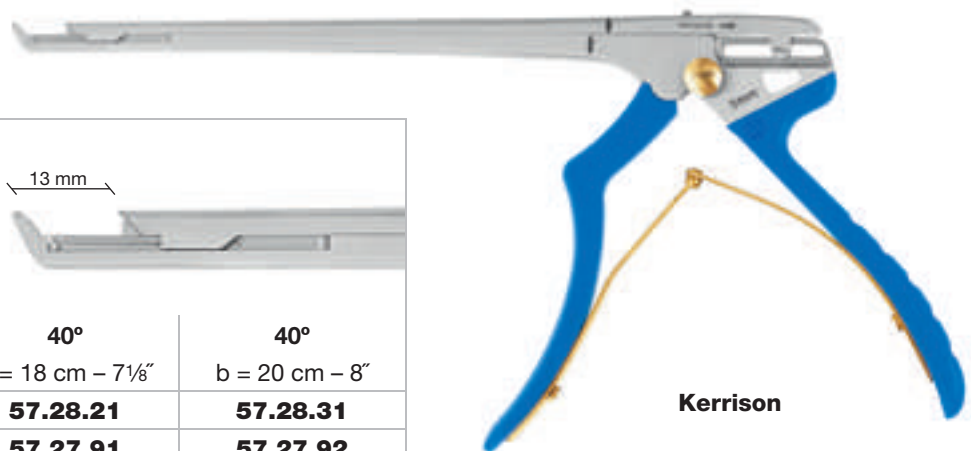

Stanzbreite Jaw width Ancho del corte Largeur des mors Larghezza de morso	D	
	40°	40°
a	b = 18 cm – 7 1/8"	b = 20 cm – 8"
1,0 mm	<b>57.28.21</b>	<b>57.28.31</b>
1,5 mm	<b>57.27.91</b>	<b>57.27.92</b>
2,0 mm	<b>57.28.22</b>	<b>57.28.32</b>
3,0 mm	<b>57.28.23</b>	<b>57.28.33</b>
4,0 mm	<b>57.28.24</b>	<b>57.28.34</b>
5,0 mm	<b>57.28.25</b>	<b>57.28.35</b>
6,0 mm	<b>57.28.26</b>	<b>57.28.36</b>

Kerrison

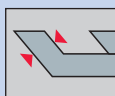

Breite Stanzplatte = graue Feder  
 Thick footplate = gray spring  
 Lámina de punzonar ancha = muelle gris  
 Plaque de poinçonnage large = ressort gris  
 Morso largo = molla grigia

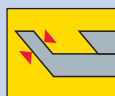

Schmale Stanzplatte = goldene Feder  
 Narrow footplate = golden spring  
 Lámina de punzonar estrecha = muelle dorada  
 Plaque de poinçonnage étroite = ressort doré  
 Morso sottile = molla dorata

**B04**

**Zerlegbare Stanzen mit Silikongriff**  
**Dismantable Rongeurs with Silicone Handle**  
**Pinzas saca-bocadas desmontables con mango de silicona**  
**Pinces emporte-pièce démontables avec manche en silicone**  
**Laminotomi smontabili con manico in silicone**

**Kerrison**  
 ...DieBLAUEN.

21  
8  
20  
19  
18  
7  
17  
6  
16  
15  
14  
5  
13  
12  
11  
4  
10  
9  
3  
8  
7  
6  
2  
5  
4  
3  
1  
2  
1  
cm  
inch



EJECTOR

b

Stanzbreite Jaw width Ancho del corte Largeur des mors Larghezza de morso	a	D	13 mm	90°	
				b = 18 cm - 7 1/8"	
1 mm				<b>57.28.41</b>	
2 mm				<b>57.28.42</b>	
3 mm				<b>57.28.43</b>	
4 mm				<b>57.28.44</b>	
5 mm				<b>57.28.45</b>	
6 mm				<b>57.28.46</b>	

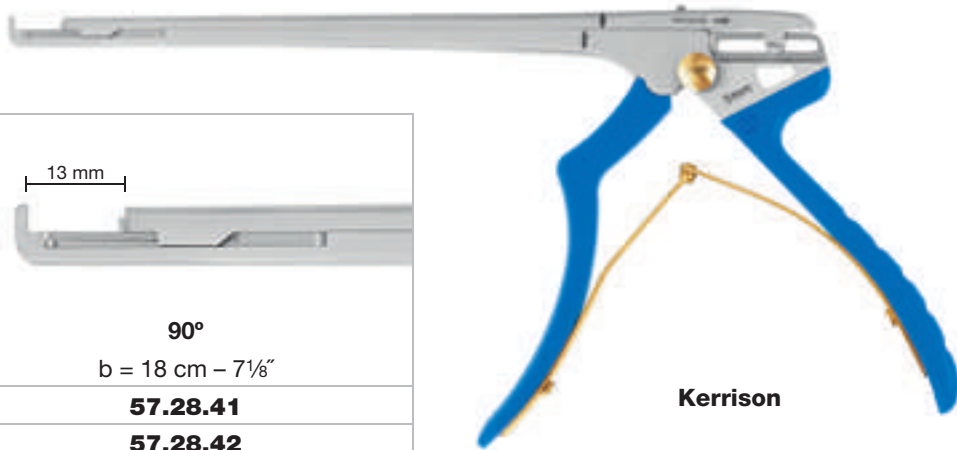
**Kerrison**

EJECTOR

b

Stanzbreite Jaw width Ancho del corte Largeur des mors Larghezza de morso	a	D	magic cut	
			40°	40°
			13 mm	
			b = 18 cm - 7 1/8"	b = 20 cm - 8"
1 mm			<b>57.28.51</b>	<b>57.28.61</b>
2 mm			<b>57.28.52</b>	<b>57.28.62</b>
3 mm			<b>57.28.53</b>	<b>57.28.63</b>
4 mm			<b>57.28.54</b>	<b>57.28.64</b>
5 mm			<b>57.28.55</b>	<b>57.28.65</b>
6 mm			<b>57.28.56</b>	<b>57.28.66</b>

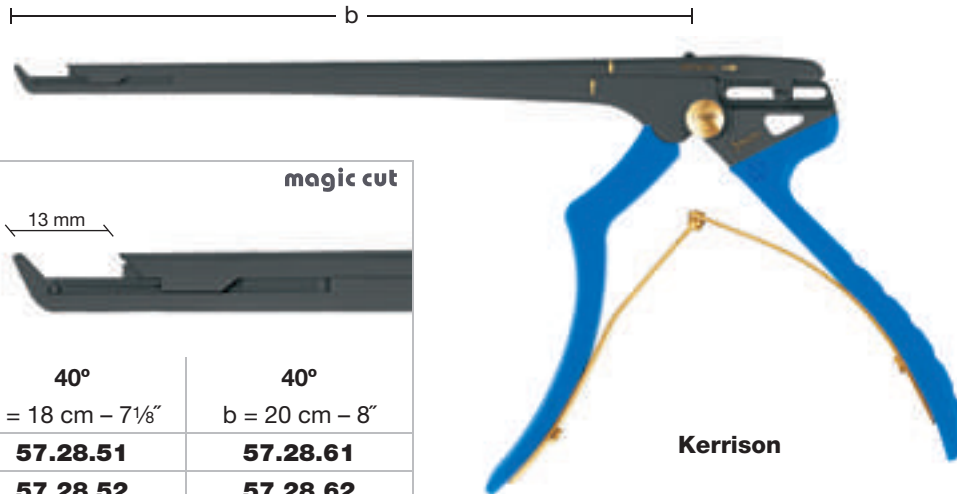
**Kerrison**

mit Auswerfer  
with ejector  
con espulsor  
avec éjecteur  
con espulsore

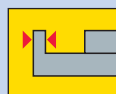

Schmale Stanzplatte = goldene Feder  
Narrow footplate = golden spring  
Lámina de punzonar estrecha = muelle dorada  
Plaque de poinçonnage étroite = ressort doré  
Morso sottile = molla dorata

Kerrison  
...DieBLAUEN.

**Zerlegbare Stanzen mit Silikongriff**  
**Dismantable Rongeurs with Silicone Handle**  
**Pinza saca-bocada desmontables con mango de silicona**  
**Pinces emporte-pièce démontables avec manche en silicone**  
**Laminotomi smontabili con manico in silicone**

**B04**

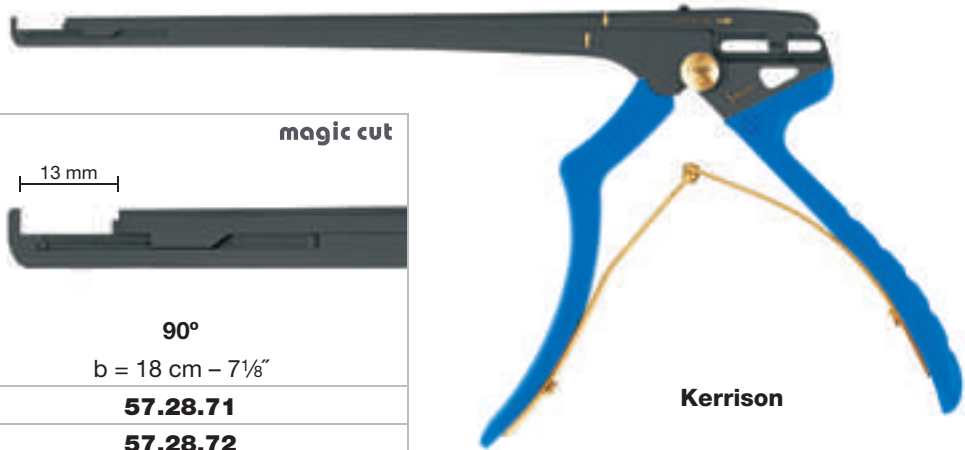
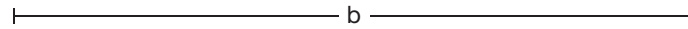

Stanzbreite Jaw width Ancho del corte Largeur des mors Larghezza de morso	D	magic cut	
		13 mm	90° b = 18 cm - 7 1/8"
1 mm	a		<b>57.28.71</b>
2 mm			<b>57.28.72</b>
3 mm			<b>57.28.73</b>
4 mm			<b>57.28.74</b>
5 mm			<b>57.28.75</b>
6 mm			<b>57.28.76</b>

**Kerrison**



Lange Standzeit, hohe Oberflächenhärte und blendfreie Oberfläche  
 Long lasting cutting ability, high surface hardness and non-dazzling surface  
 Máxima duración del corte, alta dureza de la superficie y superficie antideslumbrante  
 Longue durée de vie, grande dureté de la surface et surface non-éblouissante  
 Massima durata del taglio, alta durezza della superficie e superficie antiriflesso

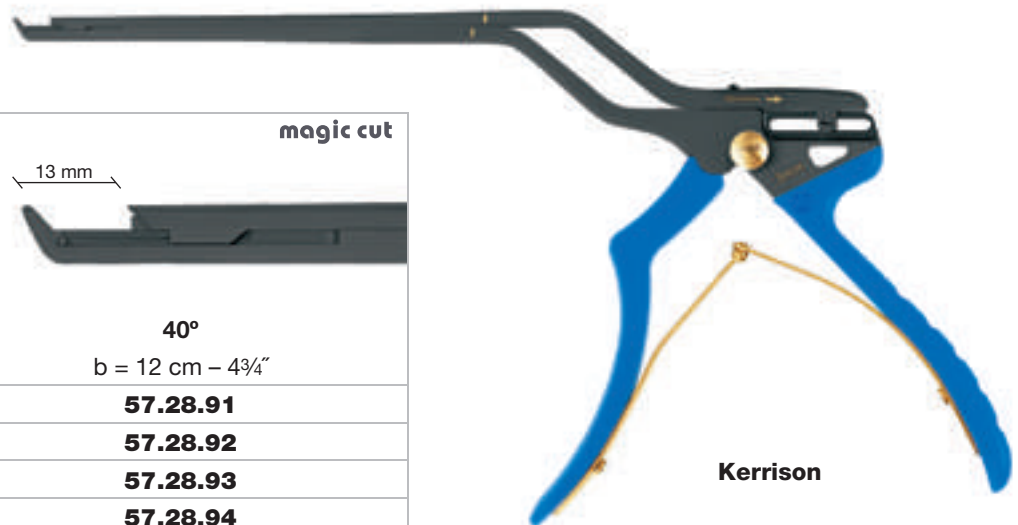
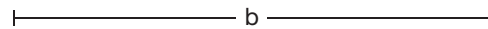

Stanzbreite Jaw width Ancho del corte Largeur des mors Larghezza de morso	D	magic cut	
		13 mm	40° b = 12 cm - 4 3/4"
1 mm	a		<b>57.28.91</b>
2 mm			<b>57.28.92</b>
3 mm			<b>57.28.93</b>
4 mm			<b>57.28.94</b>
5 mm			<b>57.28.95</b>
6 mm			<b>57.28.96</b>

**Kerrison**



mit Auswerfer  
with ejector  
con espulsor  
avec éjecteur  
con espulsore



Schmale Stanzplatte = goldene Feder  
 Narrow footplate = golden spring  
 Lámina de punzonar estrecha = muelle dorada  
 Plaque de poinçonnage étroite= ressort doré  
 Morso sottile = molla dorata

**B04**

**Stanzen**  
**Rongeurs**  
**Pinzas saca-bocadas**  
**Pinces emporte-pièce**  
**Laminotomi**

21  
8  
20  
19  
18  
7  
17  
16  
6  
15  
6  
14  
5  
13  
5  
12  
11  
4  
10  
4  
9  
3  
8  
3  
7  
2  
6  
2  
5  
2  
4  
3  
1  
3  
2  
1  
cm  
inch

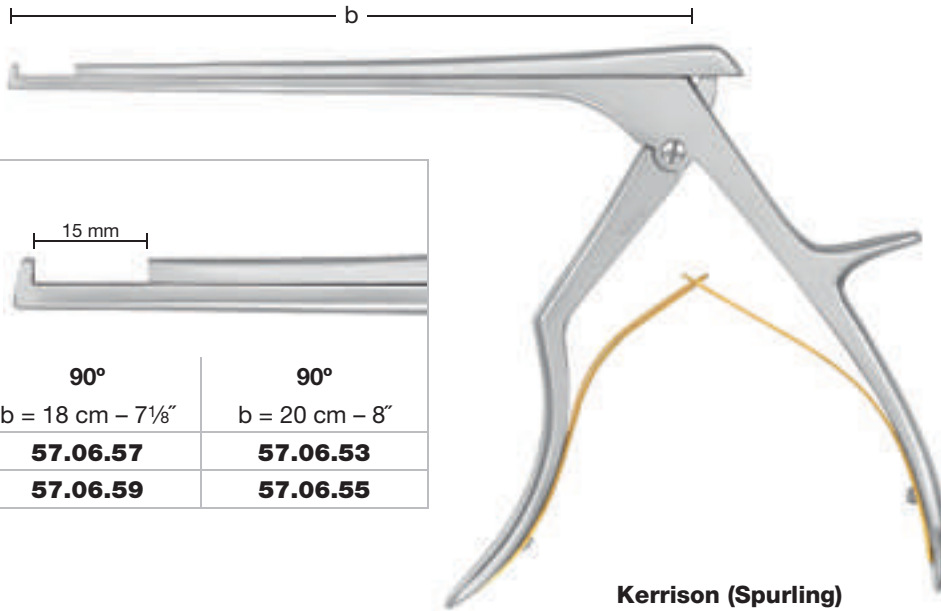

Stanzbreite Jaw width Ancho del corte Largeur des mors Larghezza de morso	D	
	a	
	90°	90°
	b = 18 cm - 7 1/8"	b = 20 cm - 8"
3 mm	<b>57.06.57</b>	<b>57.06.53</b>
5 mm	<b>57.06.59</b>	<b>57.06.55</b>

**Kerrison (Spurling)**

Griff (groß)  
 Handle (large)  
 Mango (grande)  
 Manche (grand)  
 Manico (grande)

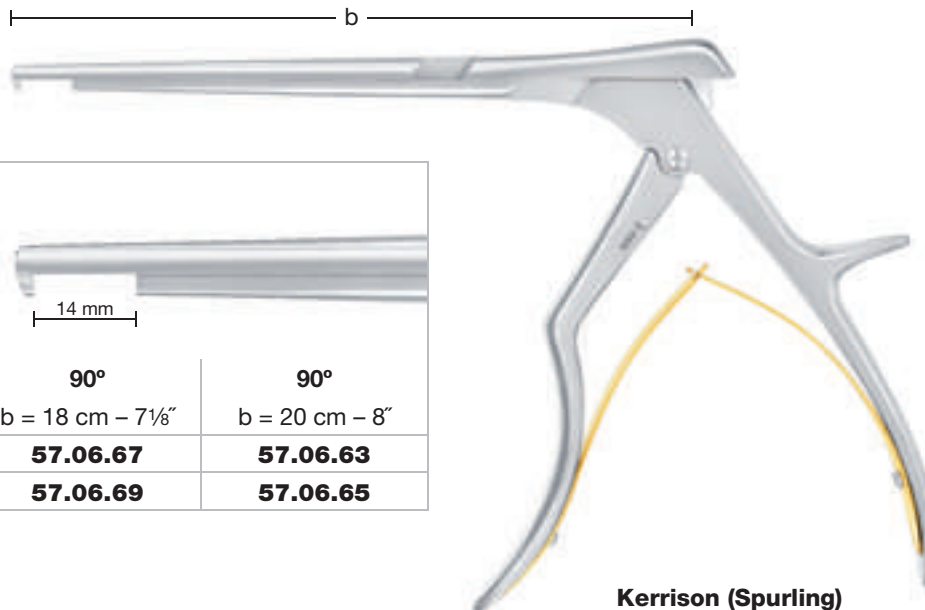
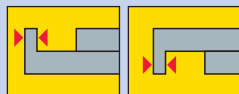

Stanzbreite Jaw width Ancho del corte Largeur des mors Larghezza de morso	D	
	a	
	90°	90°
	b = 18 cm - 7 1/8"	b = 20 cm - 8"
3 mm	<b>57.06.67</b>	<b>57.06.63</b>
5 mm	<b>57.06.69</b>	<b>57.06.65</b>

**Kerrison (Spurling)**

Schmale Stanzplatte = goldene Feder  
 Narrow footplate = golden spring  
 Lámina de punzonar estrecha = muelle dorada  
 Plaque de poinçonnage étroite = ressort doré  
 Morso sottile = molla dorata

Stanzbreite Jaw width Ancho del corte Largeur des mors Larghezza de morso		
	40° b = 18 cm - 7 1/8"	40° b = 20 cm - 8"
	3 mm <b>57.06.93</b>	5 mm <b>57.06.95</b>

**Kerrison (Schlesinger)**

Griff (groß)  
 Handle (large)  
 Mango (grande)  
 Manche (grand)  
 Manico (grande)

Stanzbreite Jaw width Ancho del corte Largeur des mors Larghezza de morso		
	40° b = 18 cm - 7 1/8"	40° b = 20 cm - 8"
	3 mm <b>57.06.43</b>	5 mm <b>57.06.45</b>

**Kerrison (Schlesinger)**

Schmale Stanzplatte = goldene Feder  
 Narrow footplate = golden spring  
 Lámina de punzonar estrecha = muelle dorada  
 Plaque de poinçonnage étroite = ressort doré  
 Morso sottile = molla dorata

**B04**

**Stanzen**  
**Rongeurs**  
**Pinzas saca-bocadas**  
**Pinces emporte-pièce**  
**Laminotomi**

21  
8  
20  
19  
18  
7  
17  
16  
6  
15  
14  
5  
13  
12  
11  
4  
10  
9  
3  
8  
7  
6  
2  
5  
4  
1  
3  
2  
1  
cm  
inch



Stanzbreite Jaw width Ancho del corte Largeur des mors Larghezza de morso	D a I	
	90° b = 18 cm - 7 1/8"	90° b = 20 cm - 8"
1 mm	<b>57.07.01</b>	<b>57.07.41</b>
2 mm	<b>57.07.02</b>	<b>57.07.42</b>
3 mm	<b>57.07.03</b>	<b>57.07.43</b>
4 mm	<b>57.07.04</b>	<b>57.07.44</b>
5 mm	<b>57.07.05</b>	<b>57.07.45</b>
6 mm	<b>57.07.06</b>	<b>57.07.46</b>

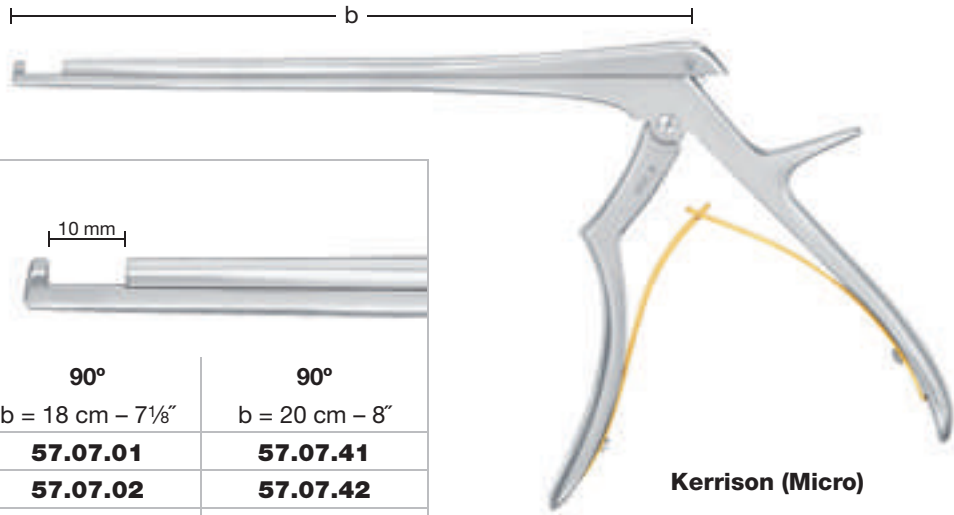

Griff (klein)  
 Handle (small)  
 Mango (pequeño)  
 Manche (petit)  
 Manico (piccolo)



Stanzbreite Jaw width Ancho del corte Largeur des mors Larghezza de morso	D a I	
	90° b = 18 cm - 7 1/8"	90° b = 20 cm - 8"
1 mm	<b>57.07.11</b>	<b>57.07.51</b>
2 mm	<b>57.07.12</b>	<b>57.07.52</b>
3 mm	<b>57.07.13</b>	<b>57.07.53</b>
4 mm	<b>57.07.14</b>	<b>57.07.54</b>
5 mm	<b>57.07.15</b>	<b>57.07.55</b>
6 mm	<b>57.07.16</b>	<b>57.07.56</b>

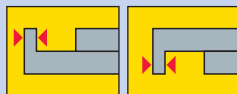
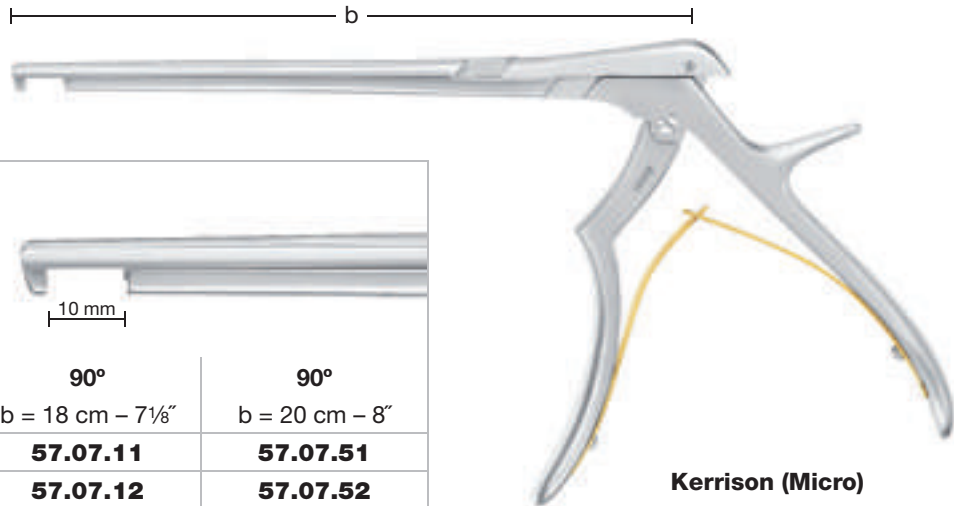

Schmale Stanzplatte = goldene Feder  
 Narrow footplate = golden spring  
 Lámina de punzonar estrecha = muelle dorada  
 Plaque de poinçonnage étroite = ressort doré  
 Morso sottile = molla dorata

Stanzbreite Jaw width Ancho del corte Largeur des mors Larghezza de morso a	40° b = 18 cm - 7 1/8"	40° b = 20 cm - 8"
	1 mm	<b>57.07.21</b>
2 mm	<b>57.07.22</b>	<b>57.07.62</b>
3 mm	<b>57.07.23</b>	<b>57.07.63</b>
4 mm	<b>57.07.24</b>	<b>57.07.64</b>
5 mm	<b>57.07.25</b>	<b>57.07.65</b>
6 mm	<b>57.07.26</b>	<b>57.07.66</b>

**Kerrison (Micro)**



Stanzbreite Jaw width Ancho del corte Largeur des mors Larghezza de morso a	40° b = 18 cm - 7 1/8"	40° b = 20 cm - 8"
	1 mm	<b>57.07.31</b>
2 mm	<b>57.07.32</b>	<b>57.07.72</b>
3 mm	<b>57.07.33</b>	<b>57.07.73</b>
4 mm	<b>57.07.34</b>	<b>57.07.74</b>
5 mm	<b>57.07.35</b>	<b>57.07.75</b>
6 mm	<b>57.07.36</b>	<b>57.07.76</b>

**Kerrison (Micro)**

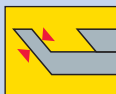

Schmale Stanzplatte = goldene Feder  
Narrow footplate = golden spring  
Lámina de punzonar estrecha = muelle dorada  
Plaque de poinçonnage étroite = ressort doré  
Morso sottile = molla dorata

**B04**

**Stanzen**  
**Rongeurs**  
**Pinzas saca-bocadas**  
**Pinces emporte-pièce**  
**Laminotomi**

21  
8  
20  
19  
18  
7  
17  
6  
16  
15  
6  
14  
5  
13  
5  
12  
11  
4  
10  
4  
9  
3  
8  
3  
7  
2  
6  
2  
5  
1  
4  
1  
3  
2  
1  
cm  
inch

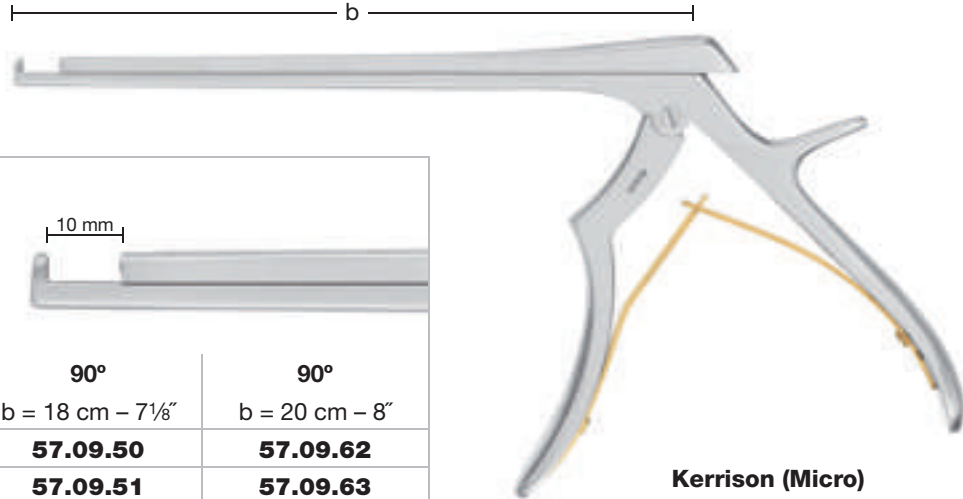

Stanzbreite Jaw width Ancho del corte Largeur des mors Larghezza de morso	D	
	90°	90°
a	b = 18 cm - 7 1/8"	b = 20 cm - 8"
2 mm	<b>57.09.50</b>	<b>57.09.62</b>
3 mm	<b>57.09.51</b>	<b>57.09.63</b>
4 mm	<b>57.09.52</b>	<b>57.09.64</b>
5 mm	<b>57.09.53</b>	<b>57.09.65</b>

**Kerrison (Micro)**

Griff (klein)  
 Handle (small)  
 Mango (pequeño)  
 Manche (petit)  
 Manico (piccolo)

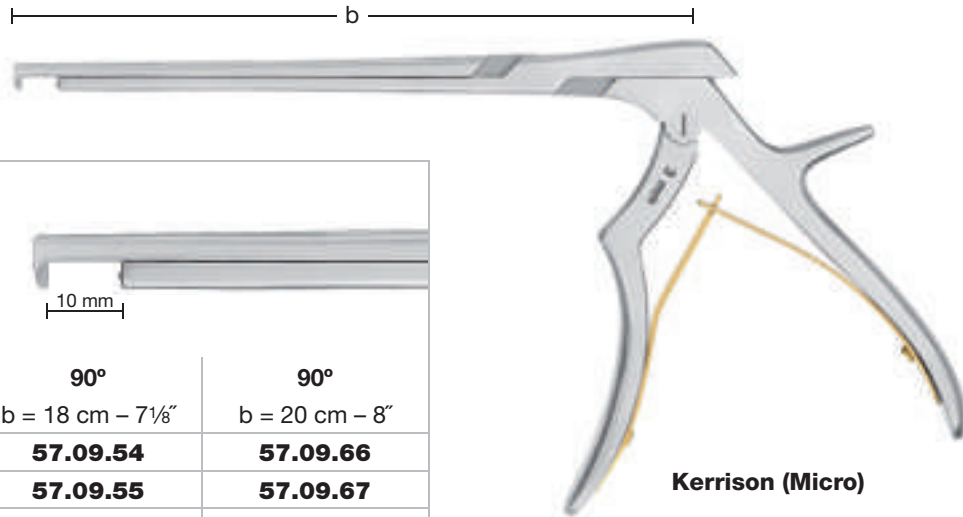

Stanzbreite Jaw width Ancho del corte Largeur des mors Larghezza de morso	D	
	90°	90°
a	b = 18 cm - 7 1/8"	b = 20 cm - 8"
2 mm	<b>57.09.54</b>	<b>57.09.66</b>
3 mm	<b>57.09.55</b>	<b>57.09.67</b>
4 mm	<b>57.09.56</b>	<b>57.09.68</b>
5 mm	<b>57.09.57</b>	<b>57.09.69</b>

**Kerrison (Micro)**

mit Auswerfer  
 with ejector  
 con espulsor  
 avec éjecteur  
 con espulsore

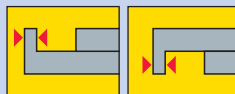

Schmale Stanzplatte = goldene Feder  
 Narrow footplate = golden spring  
 Lámina de punzonar estrecha = muelle dorada  
 Plaque de poinçonnage étroite = ressort doré  
 Morso sottile = molla dorata





**Stanzen**  
**Rongeurs**  
**Pinzas saca-bocadas**  
**Pinces emporte-pièce**  
**Laminotomi**

**B04**

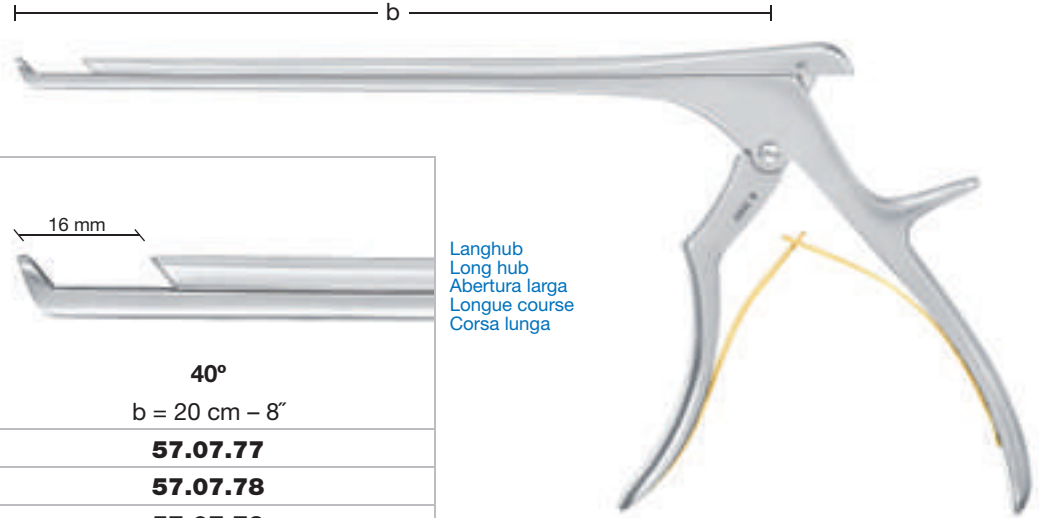

Stanzbreite Jaw width Ancho del corte Largeur des mors Larghezza de morso	 16 mm 40° b = 20 cm - 8"
1 mm	<b>57.07.77</b>
2 mm	<b>57.07.78</b>
3 mm	<b>57.07.79</b>
4 mm	<b>57.07.80</b>
5 mm	<b>57.07.81</b>
6 mm	<b>57.07.82</b>

Langhub  
 Long hub  
 Abertura larga  
 Longue course  
 Corsa lunga

**Kerrison (Micro)**



Griff (klein)  
 Handle (small)  
 Mango (pequeño)  
 Manche (petit)  
 Manico (piccolo)

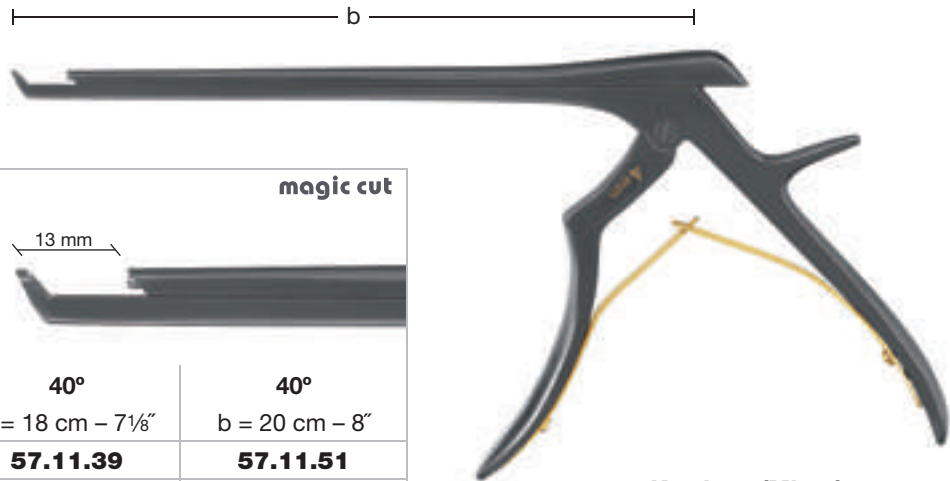

Stanzbreite Jaw width Ancho del corte Largeur des mors Larghezza de morso	magic cut	
	 13 mm 40° b = 18 cm - 7 1/8"	40° b = 20 cm - 8"
2 mm	<b>57.11.39</b>	<b>57.11.51</b>
3 mm	<b>57.11.40</b>	<b>57.11.52</b>
4 mm	<b>57.11.41</b>	<b>57.11.53</b>
5 mm	<b>57.11.42</b>	<b>57.11.54</b>

**Kerrison (Micro)**



Lange Standzeit, hohe Oberflächenhärte und blendfreie Oberfläche  
 Long lasting cutting ability, high surface hardness and non-dazzling surface  
 Máxima duración del corte, alta dureza de la superficie y superficie antideslumbrante  
 Longue durée de vie, grande dureté de la surface et surface non-éblouissante  
 Massima durata del taglio, alta durezza della superficie e superficie antiriflesso



mit Auswerfer  
 with ejector  
 con espulsor  
 avec éjecteur  
 con espulsore





Schmale Stanzplatte = goldene Feder  
 Narrow footplate = golden spring  
 Lámina de punzonar estrecha = muelle dorada  
 Plaque de poinçonnage étroite = ressort doré  
 Morso sottile = molla dorata



# B04

**Stanzen**  
**Rongeurs**  
**Pinzas saca-bocadas**  
**Pinces emporte-pièce**  
**Laminotomi**



Stanzbreite Jaw width Ancho del corte Largeur des mors Larghezza de morso 	 10 mm 90° $b = 18 \text{ cm} - 7\frac{1}{8}''$
5 mm	<b>57.10.05</b>

— b —





**Kerrison (Ferris-Smith)**



Griff (klein)  
 Handle (small)  
 Mango (pequeño)  
 Manche (petit)  
 Manico (piccolo)



Stanzbreite Jaw width Ancho del corte Largeur des mors Larghezza de morso 	 10 mm 90° $b = 18 \text{ cm} - 7\frac{1}{8}''$
5 mm	<b>57.10.15</b>

— b —



**Kerrison (Ferris-Smith)**

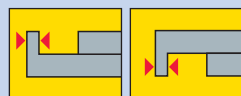

Schmale Stanzplatte = goldene Feder  
 Narrow footplate = golden spring  
 Lámina de punzonar estrecha = muelle dorada  
 Plaque de poinçonnage étroite = ressort doré  
 Morso sottile = molla dorata

**Haken und Dissektoren**  
**Hooks and Dissectors**  
**Ganchos y disectores**  
**Crochets et dissecteurs**  
**Uncini e dissectori**

**B05**

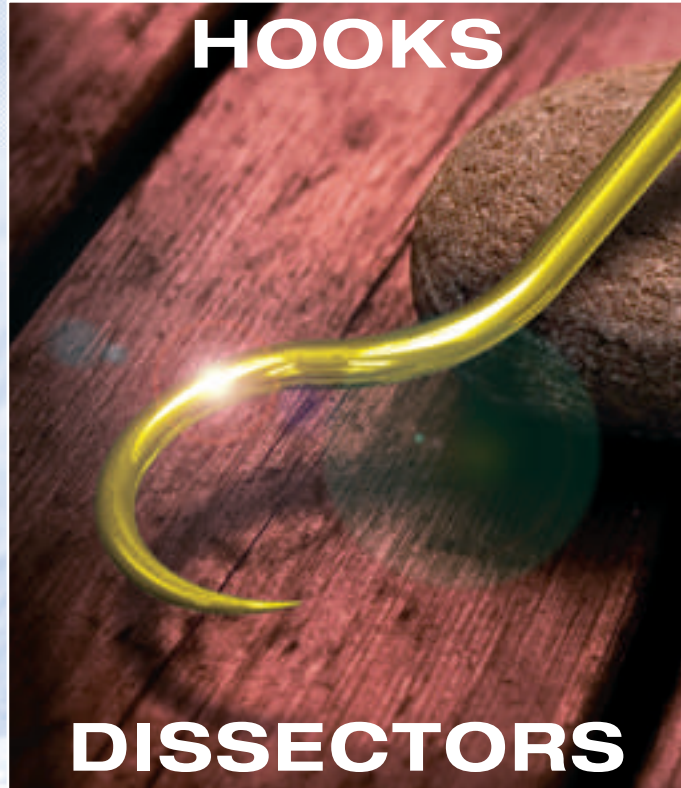



# B05

**Haken**  
**Hooks**  
**Ganchos**  
**Crochets**  
**Uncini**

Nervhäkchen  
Nerve hooks  
Ganchitos para nervios  
Crochets à nerfs  
Uncini per nervi



7 mm



16 cm – 6¼"  
**20.20.57**

9 mm



16 cm – 6¼"  
**20.20.59**



4 mm



16 cm – 6¼"  
**20.20.34**



2 mm



14 cm – 5½"  
**20.22.01**

3 mm



14 cm – 5½"  
**20.22.02**

4 mm



14 cm – 5½"  
**20.22.03**

**Lucae**

Nervhäkchen  
Nerve hooks  
Ganchitos para nervios  
Crochets à nerfs  
Uncini per nervi

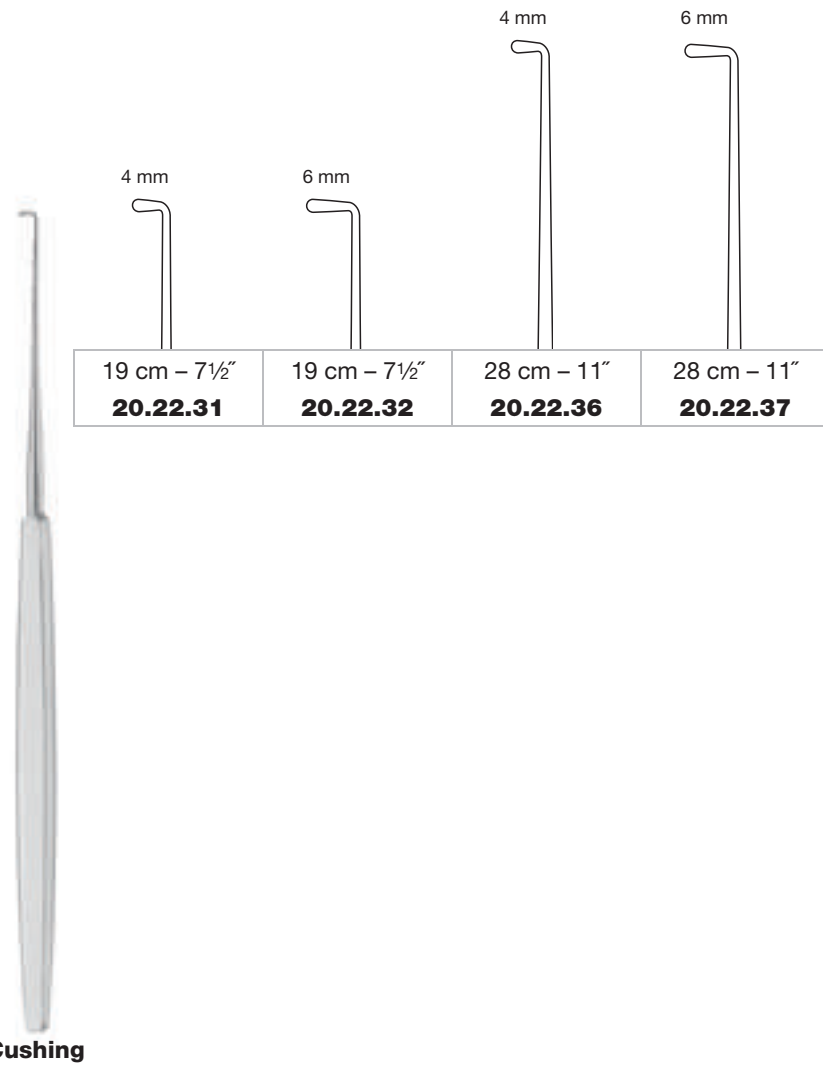



# B05

- Haken**
- Hooks**
- Ganchos**
- Crochets**
- Uncini**



2 mm

5 mm

8 mm

19 cm – 7½"  
**57.49.19**

19 cm – 7½"  
**57.49.20**

19 cm – 7½"  
**57.49.21**



3 mm

4 mm

5 mm

a = 110 mm  
 24 cm – 9½"  
**57.50.24**

a = 110 mm  
 24 cm – 9½"  
**57.50.25**

a = 110 mm  
 24 cm – 9½"  
**57.50.26**

Nervhäkchen  
 Nerve hooks  
 Ganchitos para nervios  
 Crochets à nerfs  
 Uncini per nervi

Nerv- und Gefäßhäkchen  
Nerve and vessel hooks  
Ganchitos para nervios y vasos  
Crochets à nerfs et vaisseaux  
Uncini per nervi e vasi



mit scharfer Schneide  
with sharp cutting edge  
con corte afilado  
avec tranchant aigu  
con tagliente affilato



**Eif**

2,0 mm



24 cm – 9½”  
**57.49.10**

3,0 mm



18,5 cm – 7¼”  
**58.30.31**

3,5 mm



18,5 cm – 7¼”  
**58.30.32**

2,0 mm



18,5 cm – 7¼”  
**58.30.35**

2,5 mm



18,5 cm – 7¼”  
**58.30.36**



**Krayenbühl**



Vergrößerung  
Magnification  
Engrandecimiento  
Agrandissement  
Ingrandimento



# B05

**Haken**  
**Hooks**  
**Ganchos**  
**Crochets**  
**Uncini**

Häkchen  
Hooks  
Ganchos  
Crochets  
Uncini



**Jacobson**

2,0 mm

18,5 cm - 7 1/4"  
**58.30.26**



**Fisch**

1,5 mm

18,5 cm - 7 1/4"  
**58.32.03**



1,5 mm

23 cm - 9"  
**58.32.13**



1,5 mm

23 cm - 9"  
**58.32.18**



spitz  
sharp  
agudo  
pointu  
acuta



stumpf  
blunt  
romo  
mousse  
smussa



Häkchen  
Hooks  
Ganchos  
Crochets  
Uncini

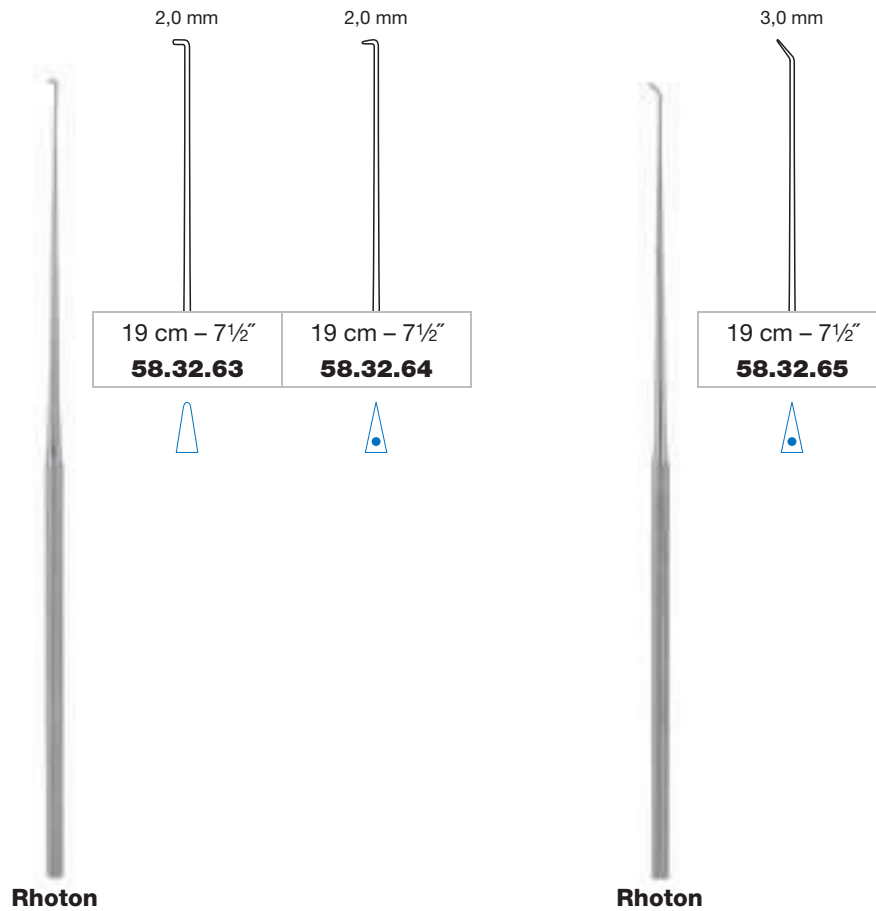

stumpf  
blunt  
romo  
mousse  
smussa

halbspitz  
semi sharp  
semi agudo  
semi pointu  
semi acuta



# B05

- Haken**
- Hooks**
- Ganchos**
- Crochets**
- Uncini**

Dura- und Hauthäkchen  
 Dura and skin hooks  
 Ganchitos para duramadre y piel  
 Crochets pour dure-mère et peau  
 Uncini per dura-madre e pelle

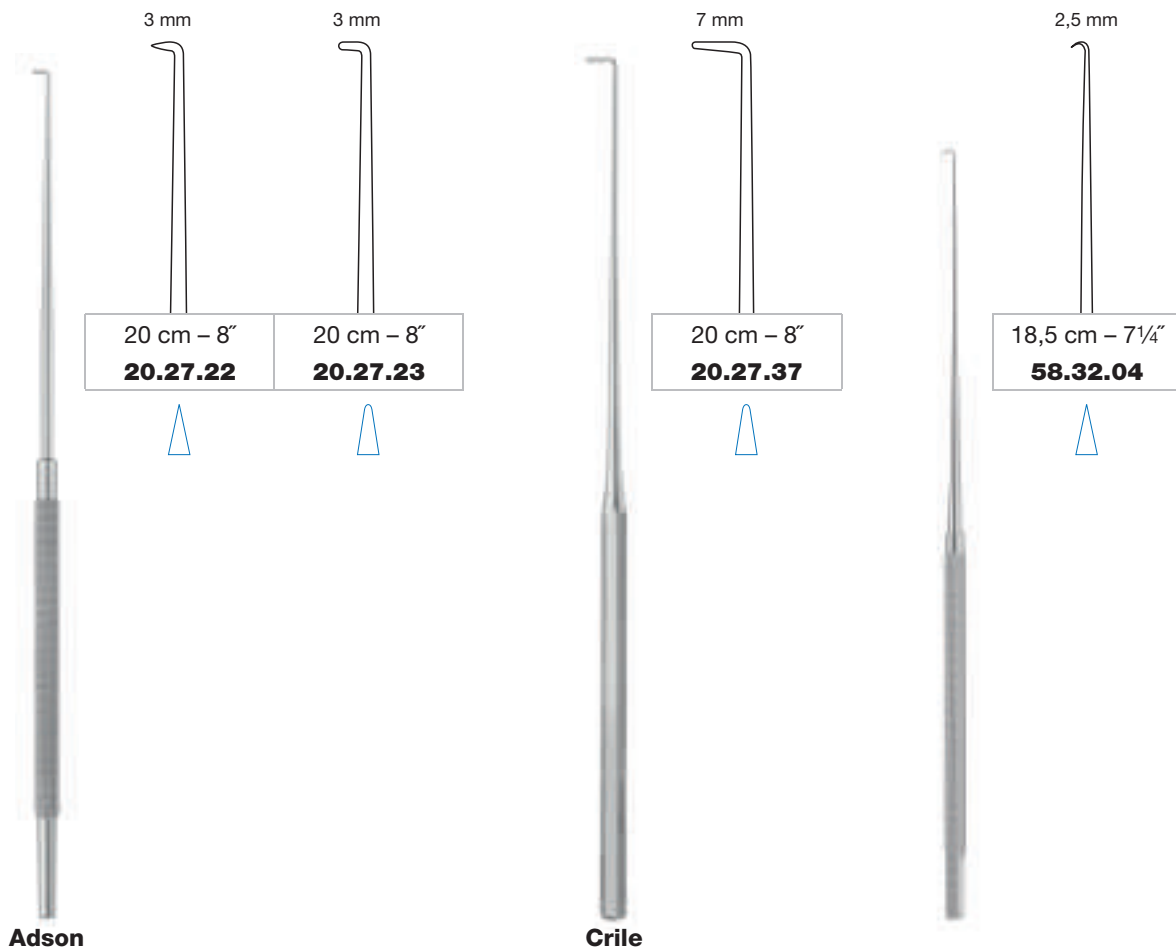

spitz  
 sharp  
 agudo  
 pointu  
 acuta



stumpf  
 blunt  
 romo  
 mousse  
 smussa

Dura- und Hauthäkchen  
Dura and skin hooks  
Ganchitos para duramadre y piel  
Crochets pour dure-mère et peau  
Uncini per dura-madre e pelle

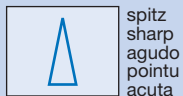
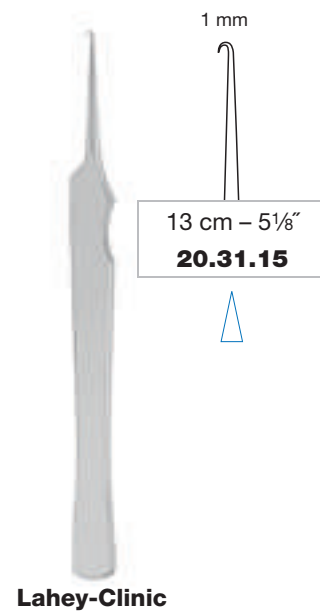
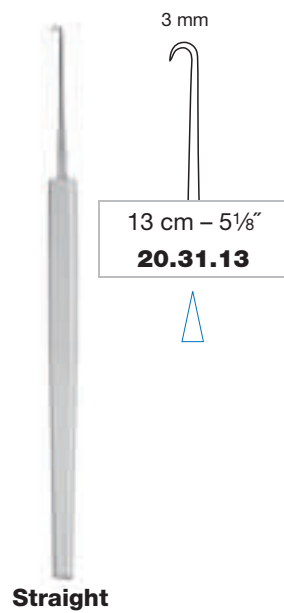
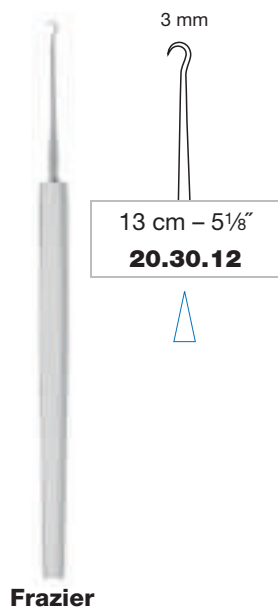
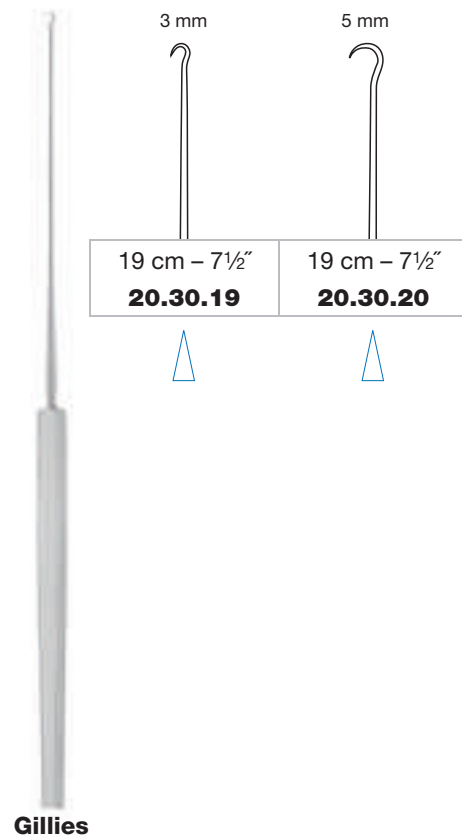



# B05

**Haken**  
**Hooks**  
**Ganchos**  
**Crochets**  
**Uncini**

Dura- und Nerv-Separatoren  
Dura and nerve separators  
Separadores para duramadre y nervios  
Séparateurs pour dure-mère et nerfs  
Separatori per dura-madre e nervi

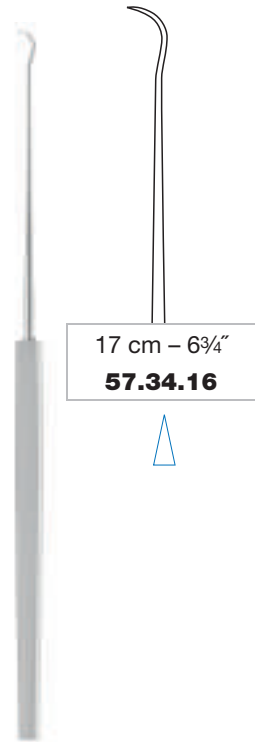

17 cm – 6¾"  
**57.34.16**

**Toennis**

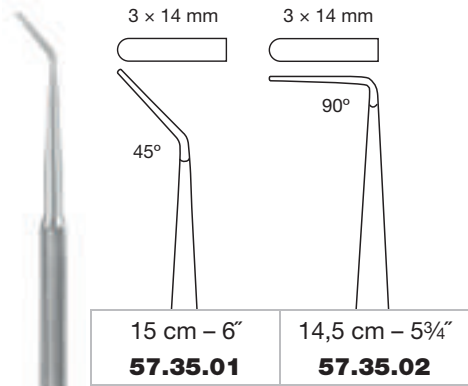

3 x 14 mm      3 x 14 mm  
45°      90°  
15 cm – 6"      14,5 cm – 5¾"  
**57.35.01**      **57.35.02**

**Hoen**

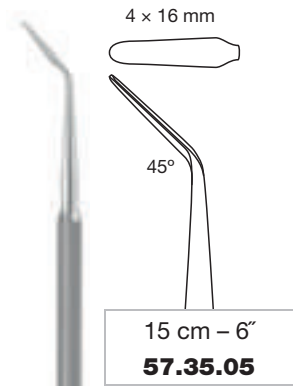

4 x 16 mm  
45°  
15 cm – 6"  
**57.35.05**

**Frazier**

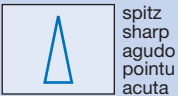

spitz  
sharp  
agudo  
pointu  
acuta

Dura- und Nerv-Separatoren  
Dura and nerve separators  
Separadores para duramadre y nervios  
Séparateurs pour dure-mère et nerfs  
Separatori per dura-madre e nervi

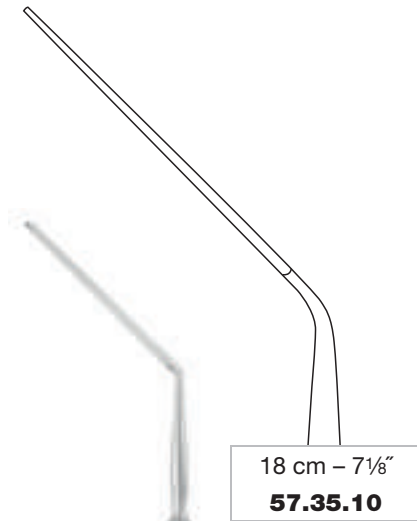
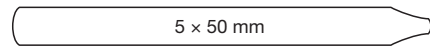

**Horsley**

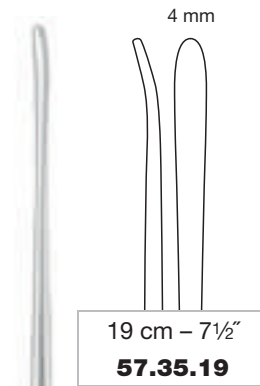

**Davis**

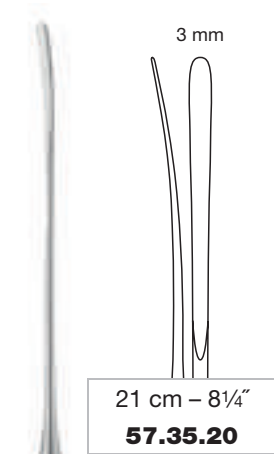

**Sachs**



# B05

**Haken**  
**Hooks**  
**Ganchos**  
**Crochets**  
**Uncini**

Explorationshäkchen  
Exploration hooks  
Ganchitos para exploración  
Crochets pour exploration  
Uncini per esplorazione

Sympathektomie-Haken  
Sympathectomy hook  
Gancho simpatectomia  
Crochet sympathectomie  
Uncino per simpatectomia

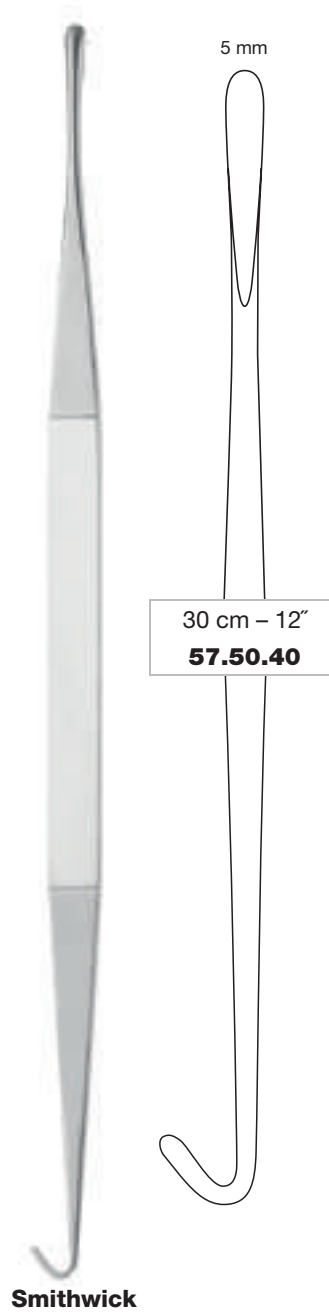
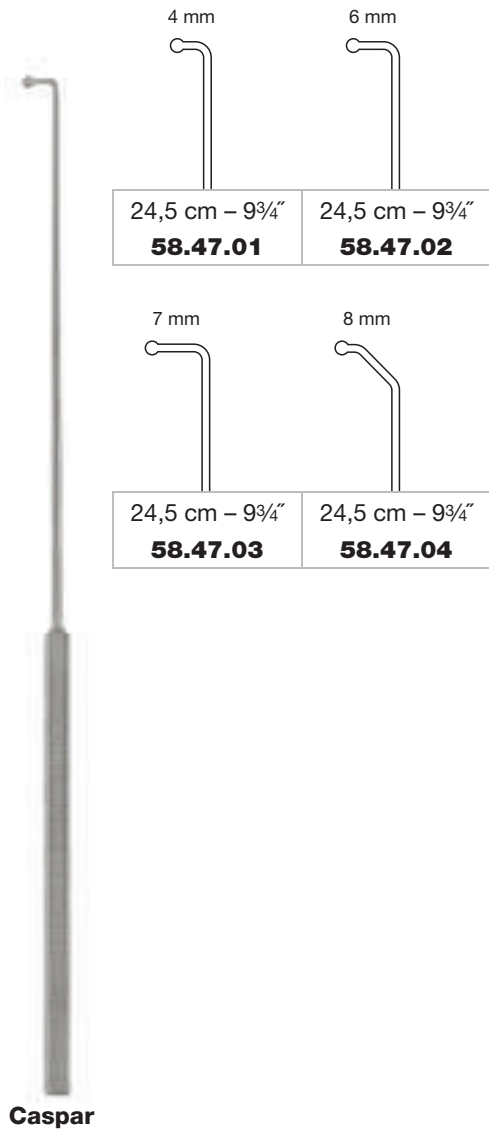

Dura-Dissektoren  
Dura dissectors  
Disectores para duramadre  
Dissecteurs pour dure-mère  
Dissettori per dura-madre

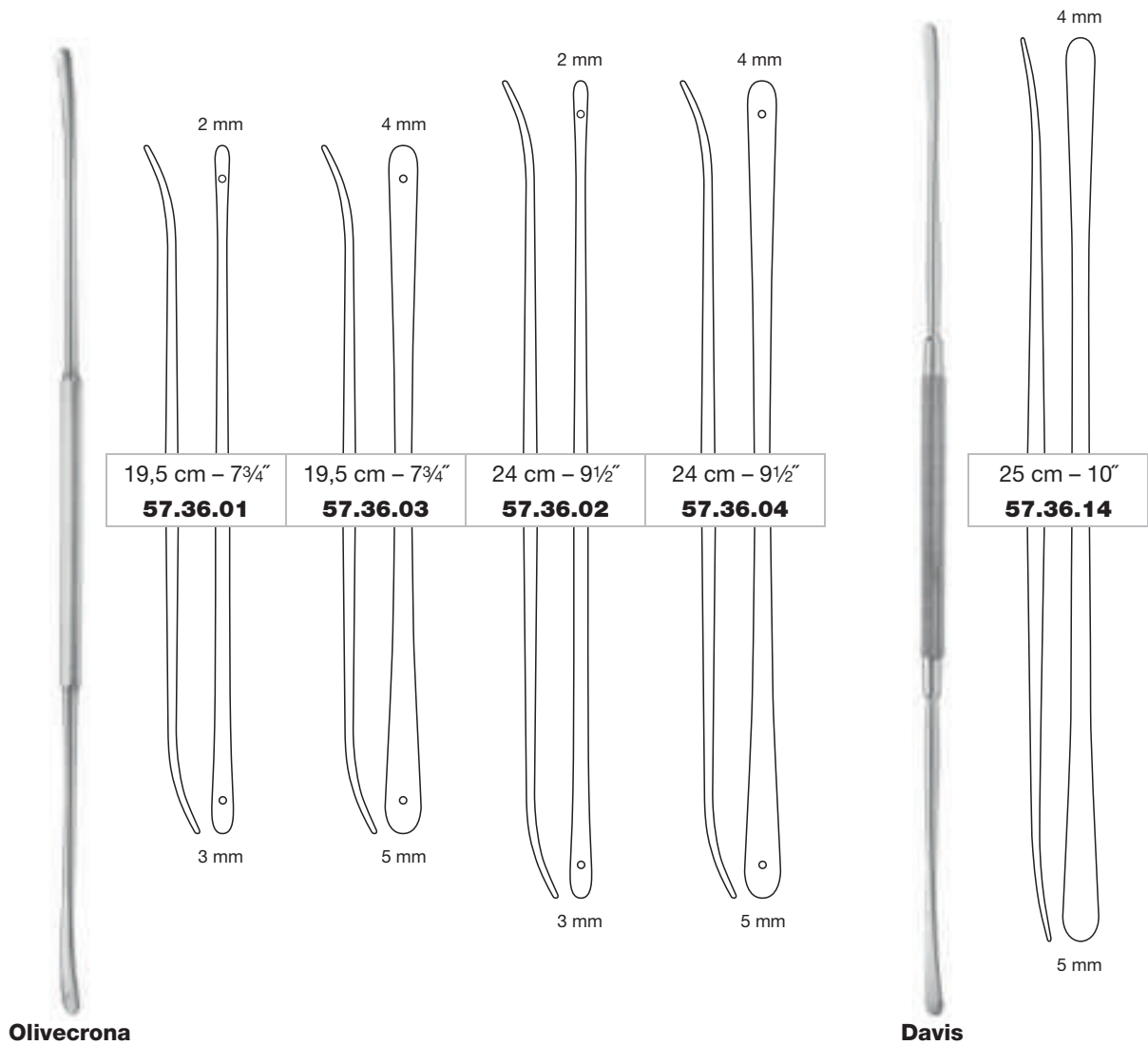



**B05**

**Dissektoren  
Dissectors  
Disectores  
Dissecteurs  
Dissettori**

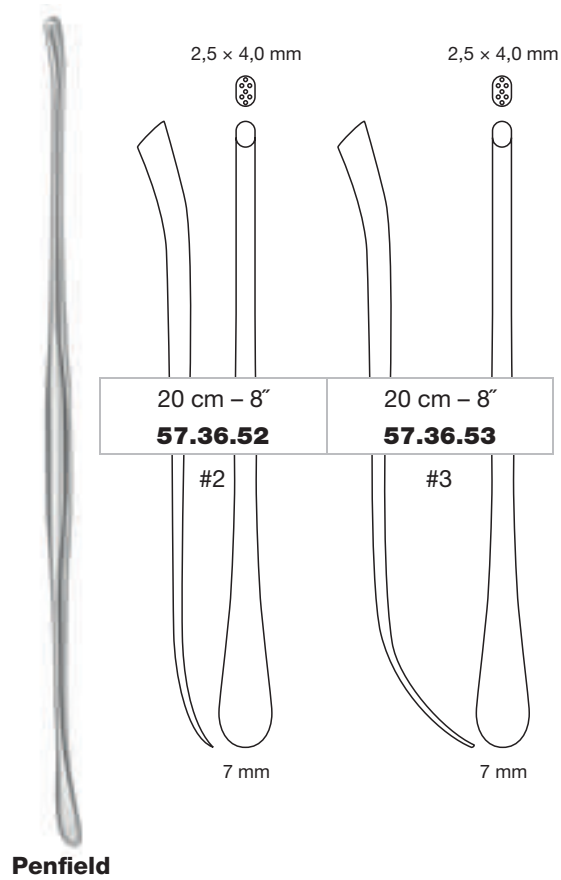
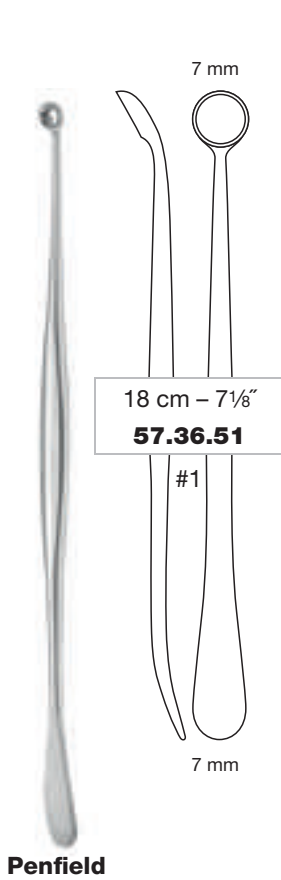





**Dissektoren**  
**Dissectors**  
**Disectores**  
**Dissecteurs**  
**Dissettori**

**B05**

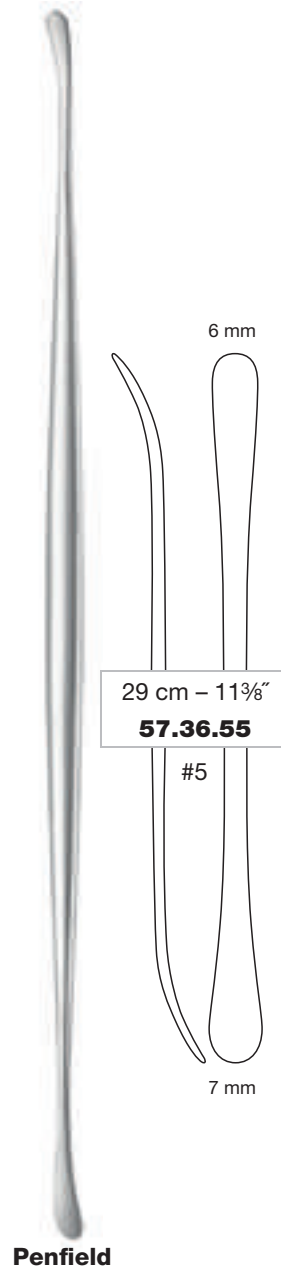
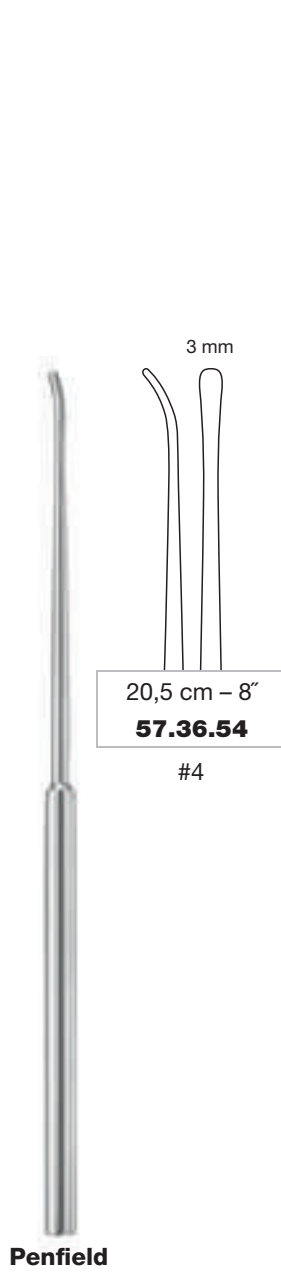



**B05**

**Dissektoren  
Dissectors  
Disectores  
Dissecteurs  
Dissettori**



**Toennis**

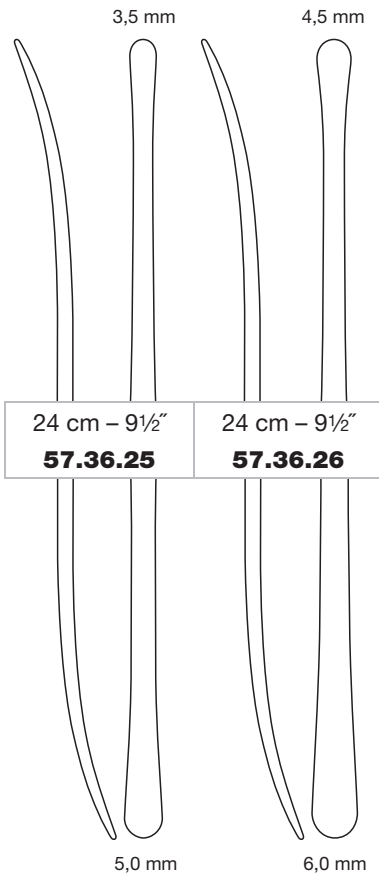

**Toennis**

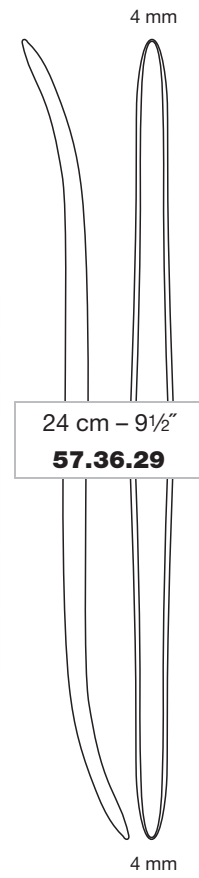

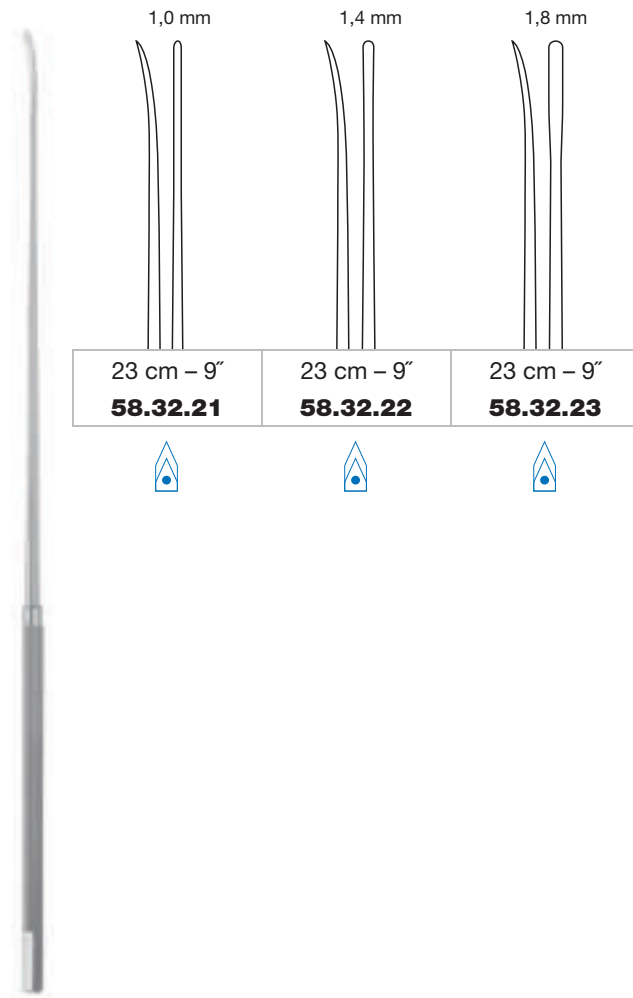
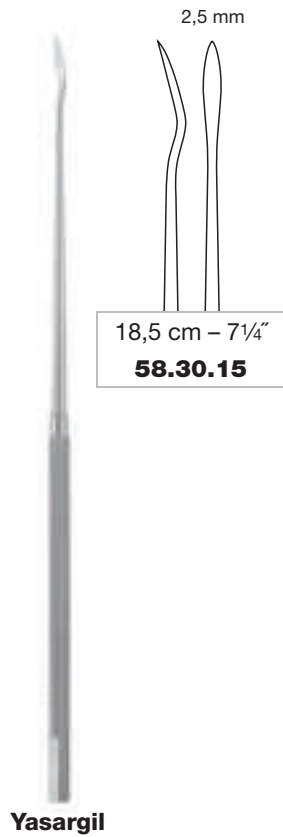



**Dissektoren  
Dissectors  
Disectores  
Dissecteurs  
Dissettori**

**B05**



1,0 mm



19 cm - 7½"  
**58.32.57**

1,5 mm



19 cm - 7½"  
**58.32.58**

2,0 mm



19 cm - 7½"  
**58.32.59**

**Rhoton**

1,2 mm



19 cm - 7½"  
**58.32.60**

**Rhoton**

2,8 mm



19 cm - 7½"  
**58.32.61**

**Rhoton**

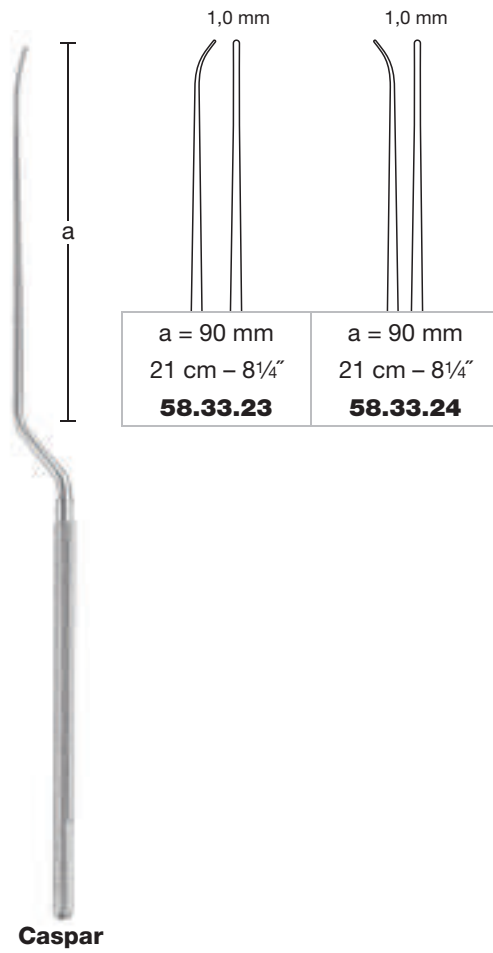



**Dissektoren  
Dissectors  
Disectores  
Dissecteurs  
Dissettori**

**B05**

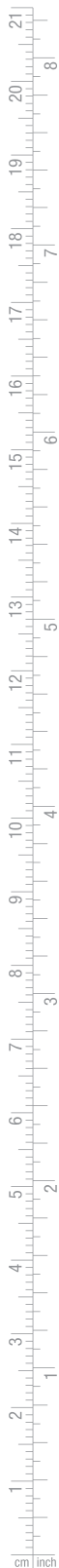

**Caspar**

2,0 mm



a = 110 mm  
23 cm - 9"  
**58.33.25**

4,5 mm



a = 110 mm  
23 cm - 9"  
**58.33.26**

4,5 mm



23 cm - 9"  
**58.33.27**



**Caspar**

3,0 mm



21,5 cm - 8½"  
**58.36.03**

3,0 mm



18,5 cm - 7¼"  
**58.36.02**



**Diamantmesser und Mikro-Instrumente**  
**Diamond Knives and Micro Instruments**  
**Cuchillos de diamante y micro instrumentos**  
**Couteaux de diamant et micro instruments**  
**Bisturi diamantati e micro strumenti**

**B06**

Klinge aus Naturdiamant ◀  
 Extreme und lang anhaltende Schärfe ◀  
 Gute Sichtkontrolle während der Inzision ◀  
 Präzise und kraftfreie Schnittführung ◀  
 Kein Einreißen des Gewebes während des Schneidens ◀

Blade made of natural diamond ◀  
 Extreme and long lasting sharpness ◀  
 Excellent visual control during incision ◀  
 Precise and force-free incision ◀  
 No tissue tearing during the incision ◀

Hoja de diamante natural ◀  
 Filo extraordinario y constante ◀  
 Buen control de la visión durante la incisión ◀  
 Corte preciso y libre de fuerza ◀  
 El tejido no rasga durante el corte ◀

Lame de diamant naturel ◀  
 Aiguisage soit exceptionnel et de longue durée ◀  
 Bon contrôle visuel pendant l'incision ◀  
 Coupe précise et sans effort ◀  
 Pas de déchirure du tissu pendant la coupe ◀

Lama di diamante naturale ◀  
 Affilatura straordinaria e di lunga durata ◀  
 Buon controllo visivo durante l'incisione ◀  
 Guida da taglio precisa e senza forza ◀  
 Nessun strappo del tessuto durante il taglio ◀



Bajonettverschluss zum Ein- und Ausfahren des Diamantmessers  
 Bayonet lock for flexion and extension of the diamond knife  
 Cierre en forma bayoneta para inserir y extraer el cuchillo de diamante  
 Verrouillage en forme baïonnette pour rentrer et sortir le couteau diamant  
 Chiusura a forma di baionetta per ritirare e far uscire il bisturi di diamante

**B06**

**Diamantmesser mit geradem Klingenhalter**  
**Diamond Knives with Straight Blade Holder**  
**Cuchillos de diamante con mango recto para hojas**  
**Couteaux de diamant avec porte-lame droit**  
**Bisturi diamantati con portalama retto**



mit Spülbohrungen  
 with irrigation holes  
 con orificios de irrigación  
 avec trous de lavage  
 con fori di lavaggio

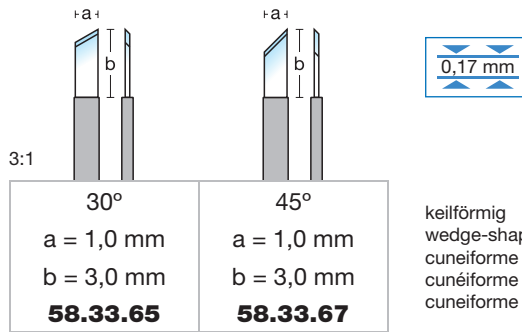

0,17 mm

keilförmig  
 wedge-shaped  
 cuneiforme  
 cunéiforme  
 cuneiforme

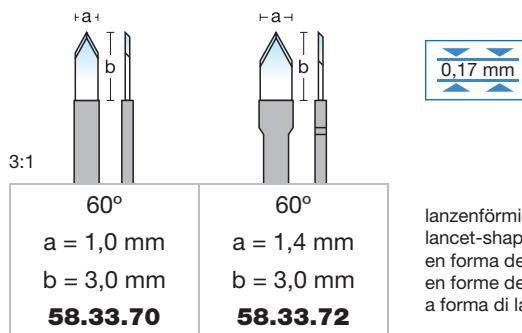

0,17 mm

lanzenförmig  
 lancet-shaped  
 en forma de lanceta  
 en forme de lance  
 a forma di lancetta

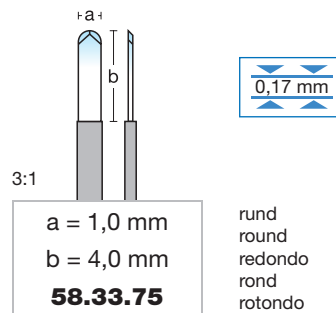

0,17 mm

rund  
 round  
 redondo  
 rond  
 rotondo

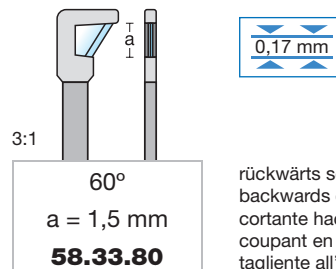

0,17 mm

rückwärts schneidend  
 backwards cutting  
 cortante hacia atrás  
 coupant en arrière  
 tagliente all'indietro

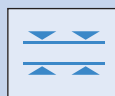

Messerdicke  
 Thickness of knives  
 Grosor de los cuchillos  
 Epaisseur de la lame  
 Spessore dei bisturi



**Diamantmesser mit gewinkeltem Klingenhalter**  
**Diamond Knives with Angled Blade Holder**  
**Cuchillos de diamante con mango angulado para hojas**  
**Couteaux de diamant avec porte-lame coudé**  
**Bisturi diamantati con portalama angolato**

**B06**

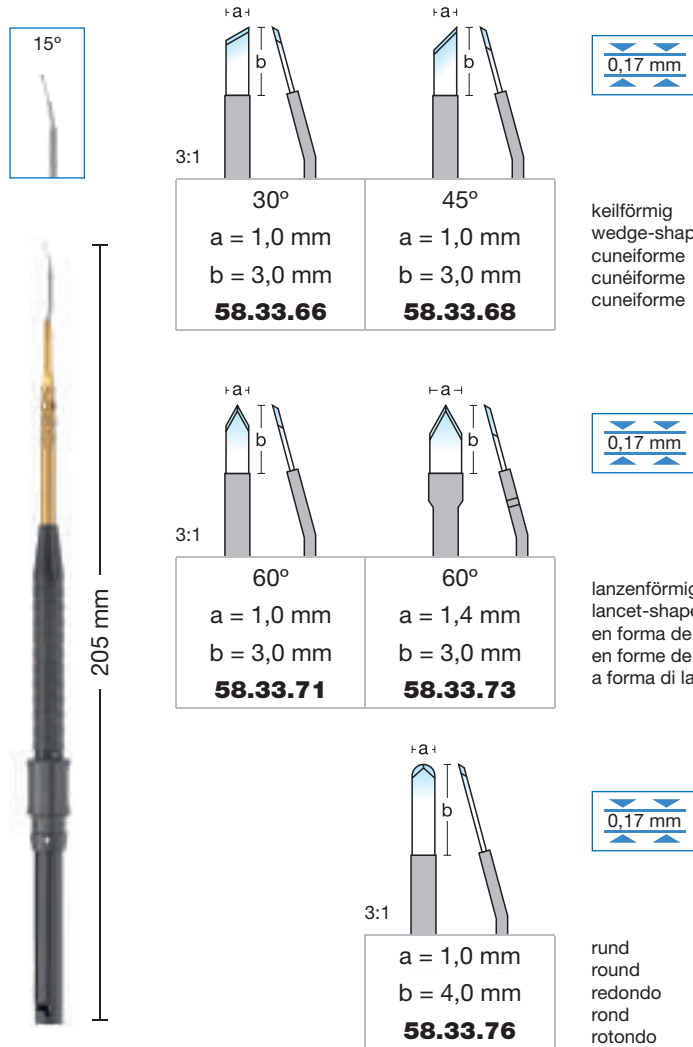

mit Spülbohrungen  
with irrigation holes  
con orificios de irrigación  
avec trous de lavage  
con fori di lavaggio



Kassette für 12 Instrumente  
Tray for 12 instruments  
Caja para 12 instrumentos  
Cassette pour 12 instruments  
Cassetta per 12 strumenti

mit Haltestegen für festen und sicheren Halt  
with holding device for a firm and safe storage  
con dispositivo de fijación para una sujeción buena y segura  
avec dispositif de fixation pour une fixation sûre  
con dispositivo di fissaggio per un fissaggio sicuro



**49.90.04**

203 × 114 × 30 mm



Kunststoff (autoklavierbar bis 134 °C bei 3 bar)  
Plastic (autoclavable up to 134 °C at 3 bar)  
Plástico (autoclavable hasta 134 °C bajo presión de 3 bar)  
Plastique (autoclavable à 134 °C sous pression de 3 bars)  
Plastica (autoclavabile fino a 134 °C sotto pressione di 3 bar)

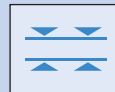

Messerdicke  
Thickness of knives  
Grosor de los cuchillos  
Epaisseur de la lame  
Spessore dei bisturi

# the art of surgery

Weitere MEDICON-Produkte finden Sie in unserem Hauptkatalog.

You will find further MEDICON products in our main catalogue.

Más productos de MEDICON se encuentra en nuestro catálogo general.

Vous trouverez d'autres produits MEDICON dans notre catalogue général.

Altri prodotti MEDICON si trovano nel nostro catalogo generale.

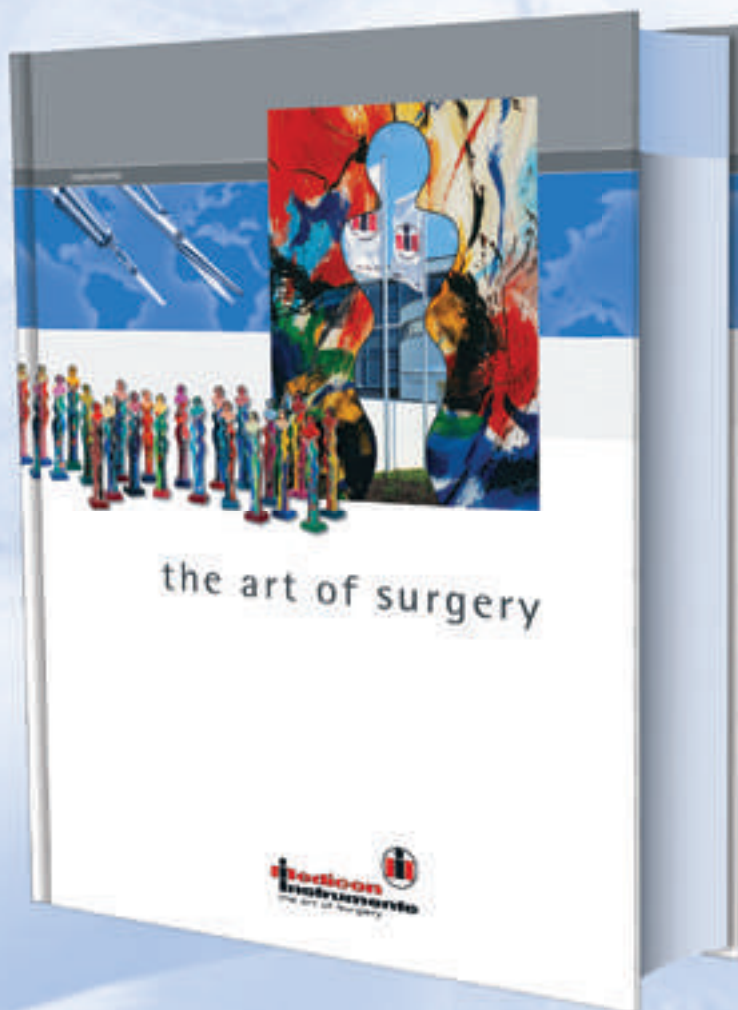

**450.00.03**

Knopfsonden  
 Button probes  
 Sondas abotonadas  
 Sondes boutonnées  
 Sonde bottonute

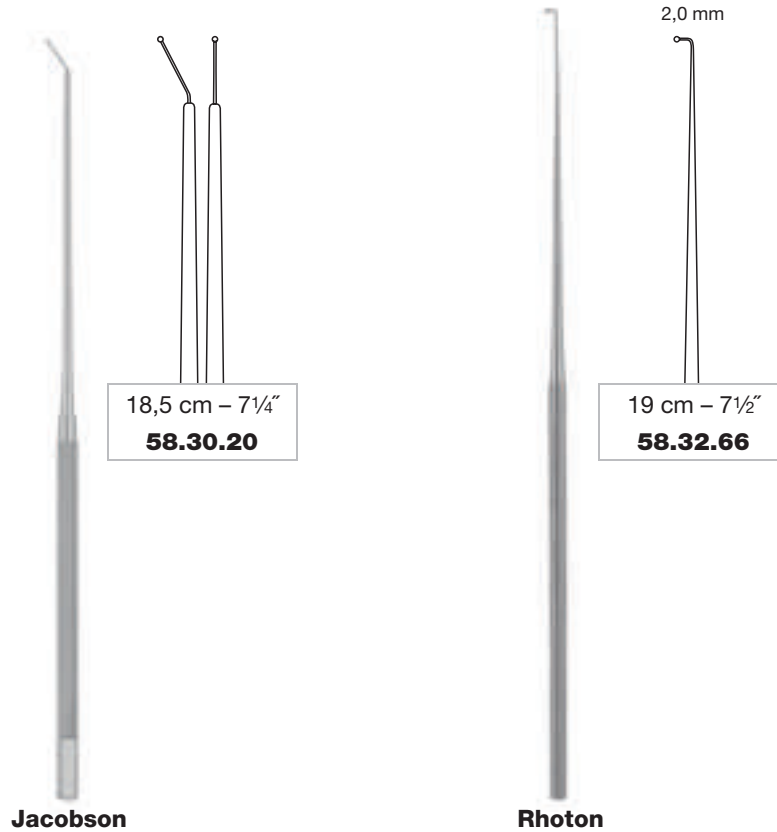

Gefäßdilatoren  
 Vessel dilators  
 Dilatadores vasculares  
 Dilatateurs vasculaires  
 Dilatatori vascolari

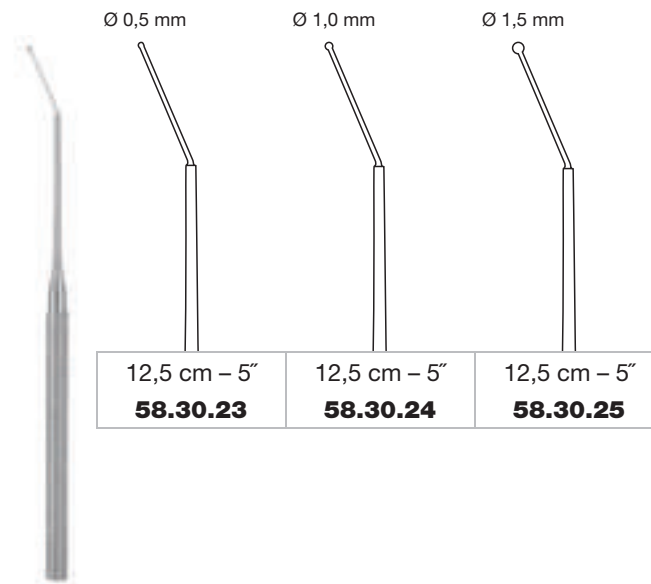



# B06

**Mikro-Instrumente**  
**Micro Instruments**  
**Micro instrumentos**  
**Micro instruments**  
**Micro strumenti**



Raspatorien  
 Raspatories  
 Legras  
 Rugines  
 Periostotomi

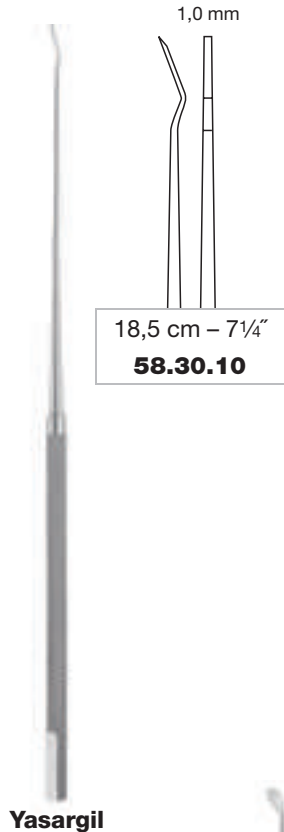

**Yasargil**

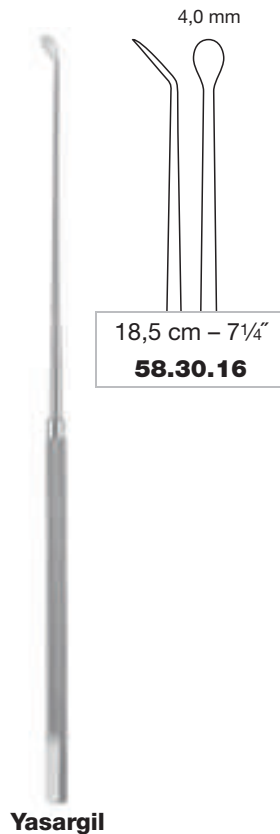

**Yasargil**

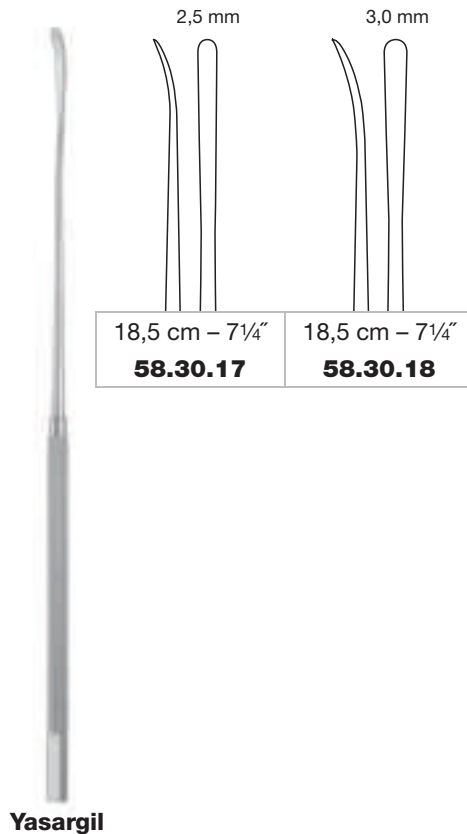

**Yasargil**

Raspatorien  
 Raspatories  
 Legras  
 Rugines  
 Periostotomi



**Rhoton**

Ø 1,0 mm



19 cm – 7½"

**58.32.54**

Ø 2,0 mm



19 cm – 7½"

**58.32.55**

Ø 3,0 mm



19 cm – 7½"

**58.32.56**

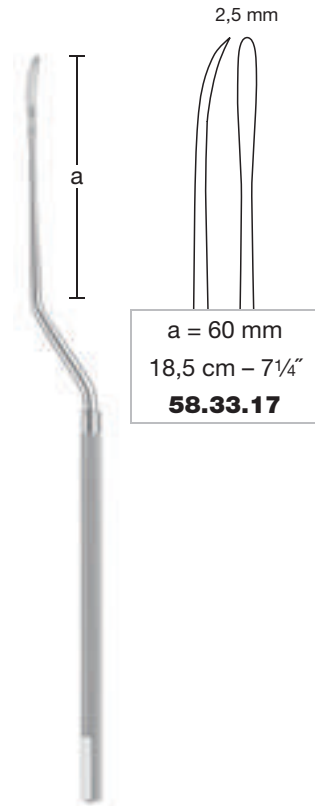

**Yasargil**

2,5 mm

a

a = 60 mm

18,5 cm – 7¼"

**58.33.17**



# B06

**Mikro-Instrumente**  
**Micro Instruments**  
**Micro instrumentos**  
**Micro instruments**  
**Micro strumenti**

Raspatorien  
 Raspatories  
 Legras  
 Rugines  
 Periostotomi

Gefäßmesser  
 Vessel knife  
 Cuchillo para vaso  
 Couteau pour vaisseaux  
 Coltello per vasi



**Yasargil**

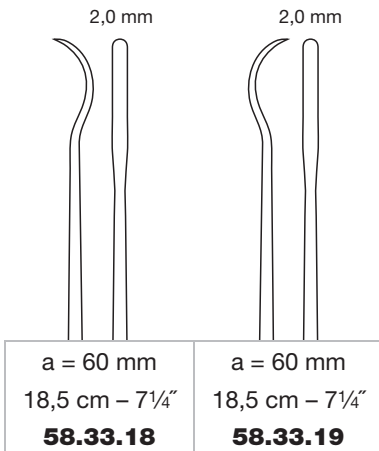

**Jacobson**

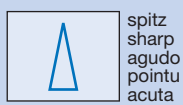
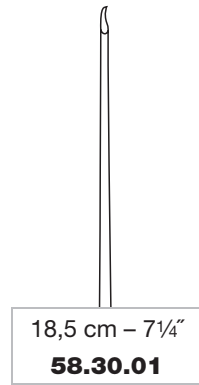

Gefäßmesser  
 Vessel knives  
 Cuchillos para vasos  
 Couteaux pour vaisseaux  
 Coltelli per vasi

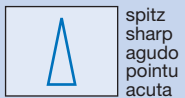
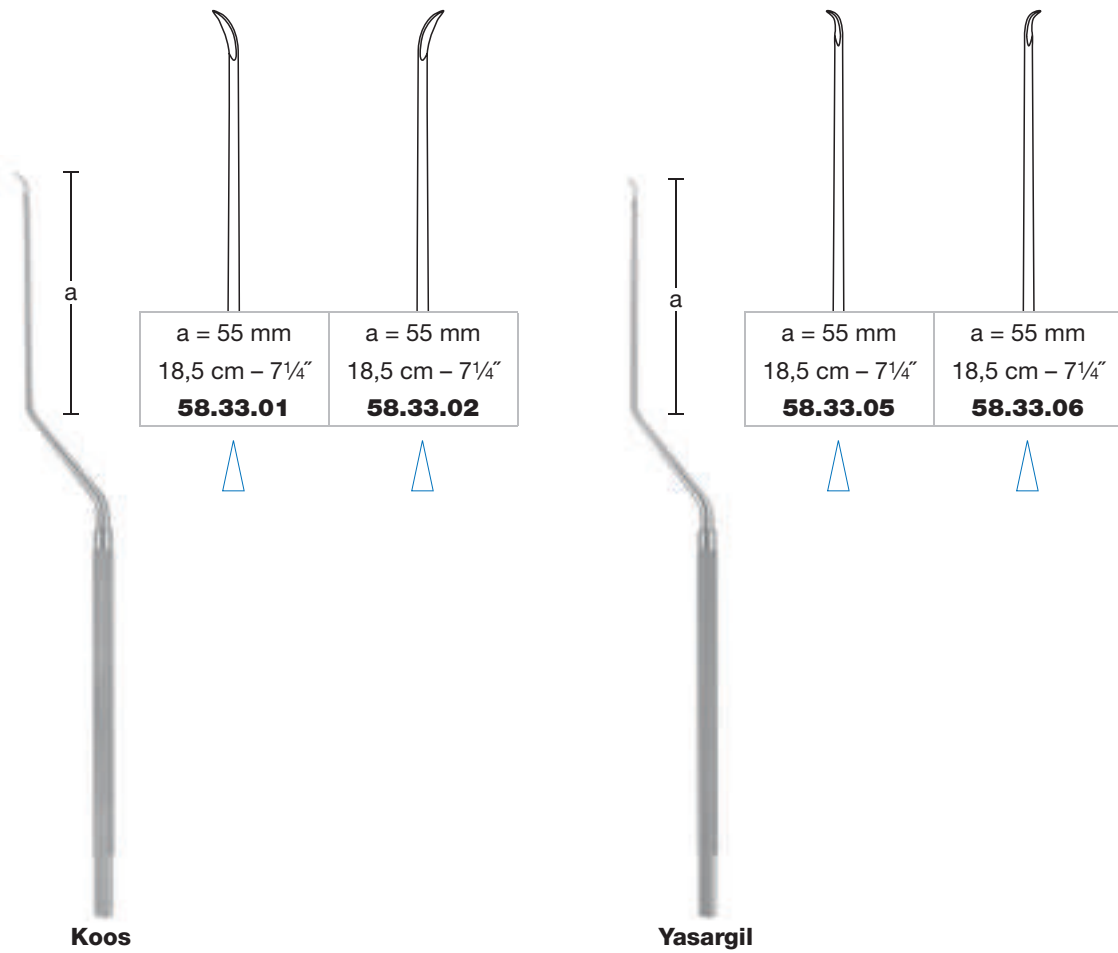



# B06

**Mikro-Instrumente**  
**Micro Instruments**  
**Micro instrumentos**  
**Micro instruments**  
**Micro strumenti**

Tumormesser  
 Tumor knives  
 Cuchillos para tumores  
 Couteaux à tumeurs  
 Coltelli per tumori

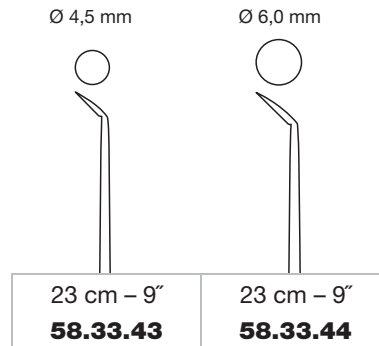
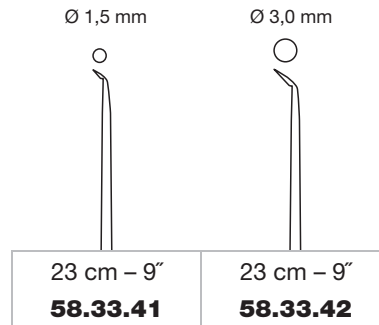
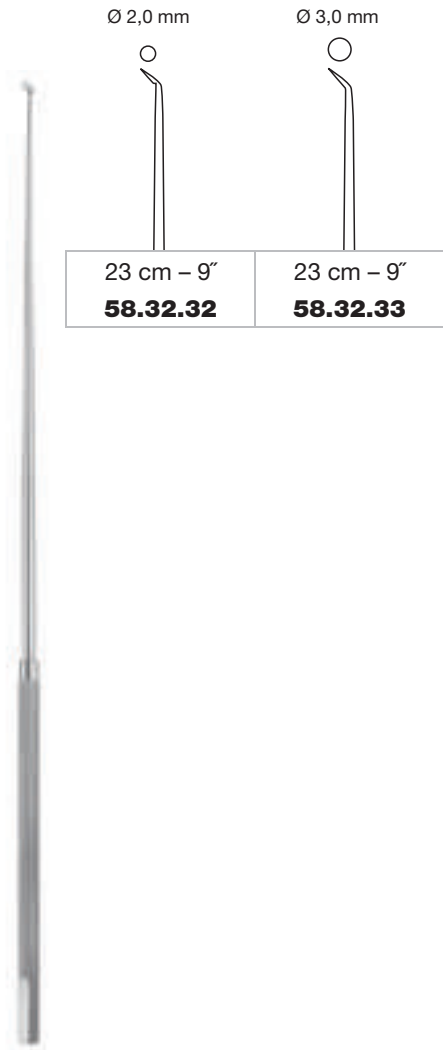

**Samii**



Lanzettenmesser  
 Lancet knives  
 Cuchillos en forma de lanceta  
 Couteaux lancéolaires  
 Coltelli lanceolati

Gewebekrallen  
 Tissue claws  
 Garras para tejido  
 Griffes tissulaires  
 Artigli per tessuti

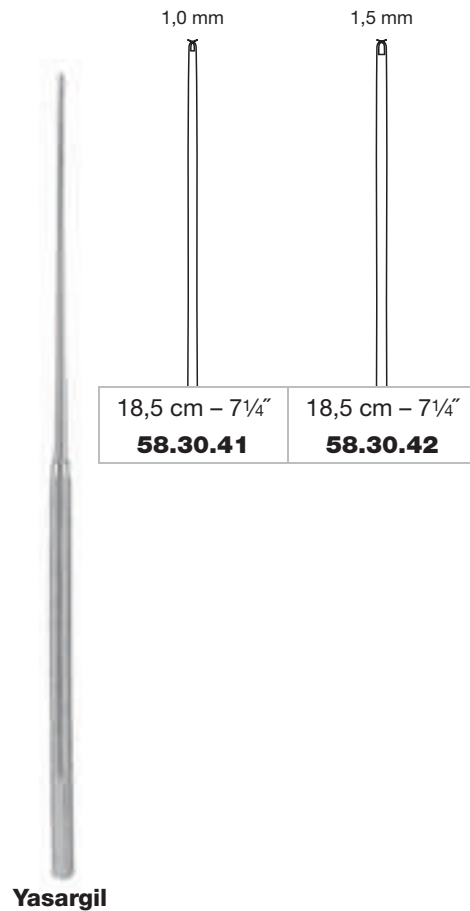
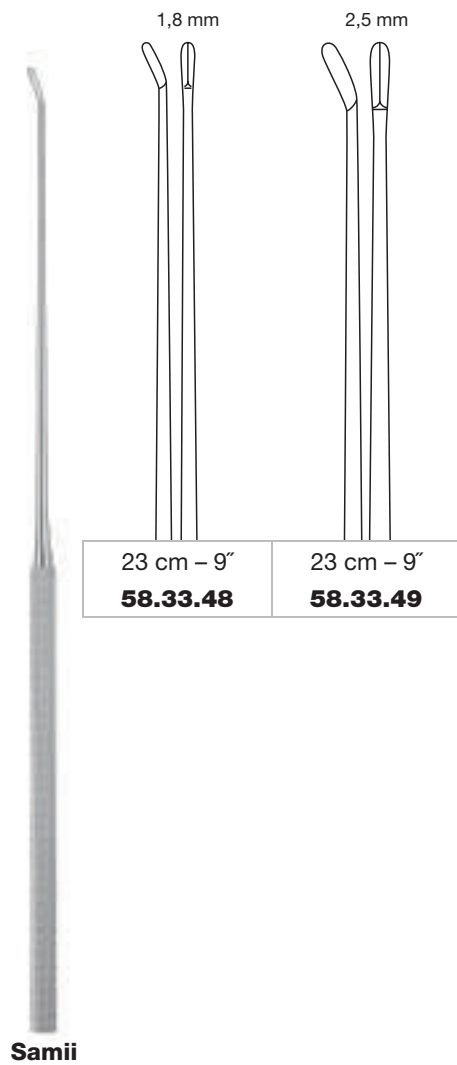



# B06

**Mikro-Instrumente**  
**Micro Instruments**  
**Micro instrumentos**  
**Micro instruments**  
**Micro strumenti**

Fadengabel  
 Ligature fork  
 Horquilla de hilos  
 Pousse-fil  
 Forchetta da sutura

Fadenführer  
 Ligature guides  
 Guía-ligadura  
 Guide-fils  
 Passafilo

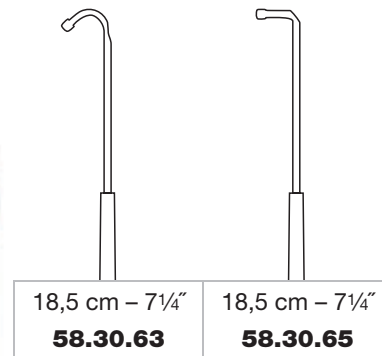
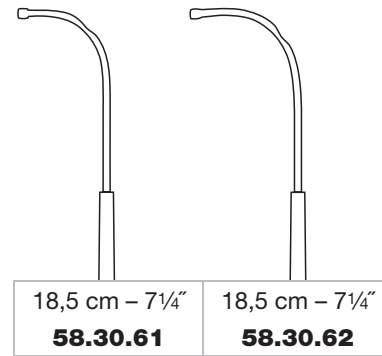
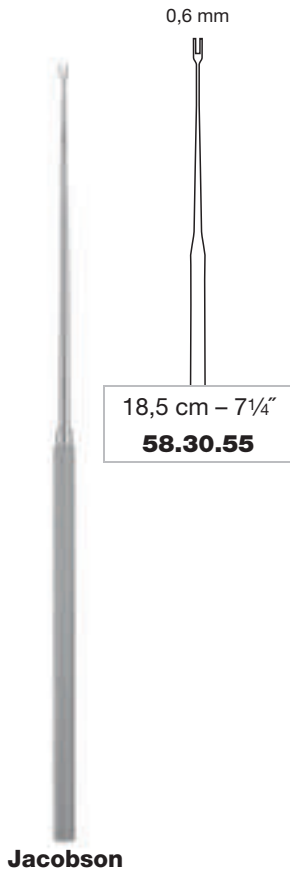
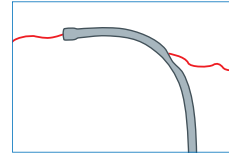

**Yasargil**

Scharfe Löffel  
 Sharp curettes  
 Cucharillas cortantes  
 Curettes tranchantes  
 Cucchiari taglienti

Nadel  
 Needle  
 Aguja  
 Aiguille  
 Ago

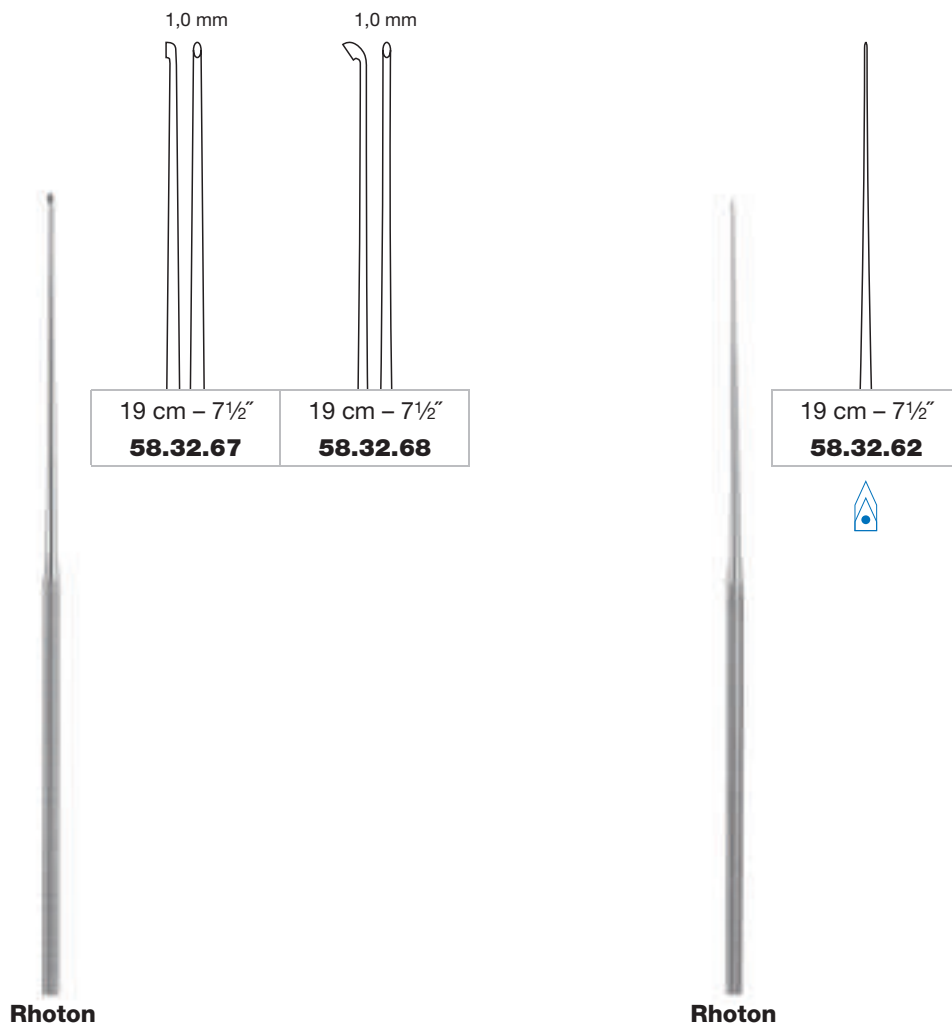

halbscharf  
 semi sharp  
 semi cortante  
 semi tranchant  
 semi acuta



# B06

**Mikro-Instrumente**  
**Micro Instruments**  
**Micro instrumentos**  
**Micro instruments**  
**Micro strumenti**

Küretten  
 Curettes  
 Curetas  
 Curettes  
 Curette

Scharfer Löffel  
 Sharp curette  
 Cucharilla cortante  
 Curette tranchante  
 Cucchiaino tagliente

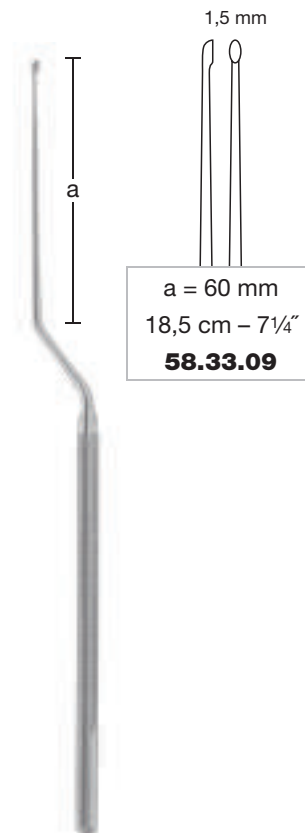
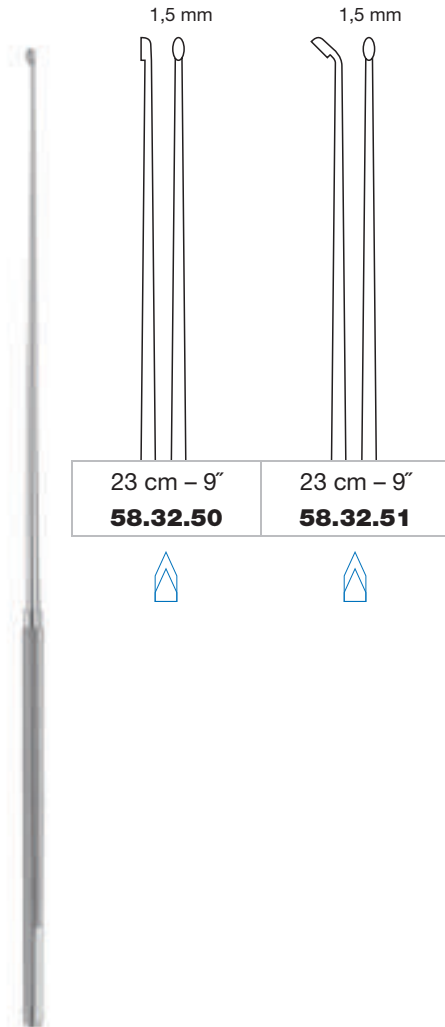

scharf  
 sharp  
 cortante  
 tranchant  
 acuta



**Hirnspatel und Hirnspatelhalter**  
**Brain Spatulas and Brain Spatula Retractors**  
**Espátulas cerebrales y separadores para espátulas cerebrales**  
**Spatules cérébrales et ecarteurs pour des spatules cérébrales**  
**Spatole cerebrali e divaricatori cerebrali**

**B07**

# BRAIN SPATULAS

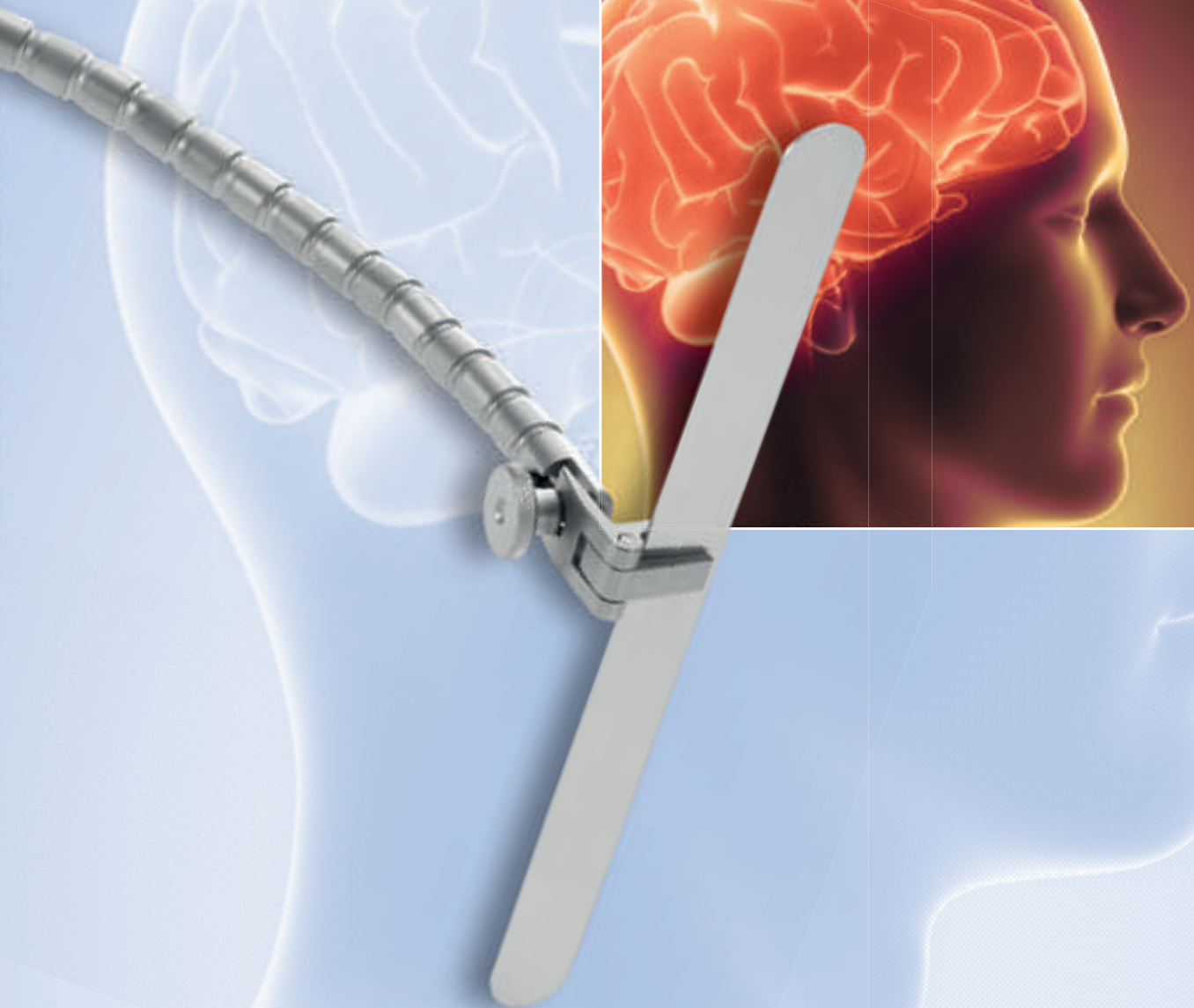

**B07**

**Hirnspatel**  
**Brain Spatulas**  
**Espátulas cerebrales**  
**Spatulas cérébrales**  
**Spatole cerebrali**

21  
8  
20  
19  
18  
7  
17  
16  
6  
15  
14  
5  
13  
12  
11  
4  
10  
9  
3  
7  
6  
5  
2  
4  
3  
1  
2  
1  
cm inch

**Davis**

a = 13 mm	18 cm - 7 1/8"	<b>57.29.19</b>	b = 13 mm
a = 16 mm	18 cm - 7 1/8"	<b>57.29.20</b>	b = 16 mm



20 cm - 8"	<b>57.32.14</b>	b = 14 mm
20 cm - 8"	<b>57.32.17</b>	b = 17 mm
20 cm - 8"	<b>57.32.20</b>	b = 20 mm



15,5 cm - 6 1/8"	<b>57.33.08</b>	b = 8 mm
15,5 cm - 6 1/8"	<b>57.33.11</b>	b = 11 mm
15,5 cm - 6 1/8"	<b>57.33.14</b>	b = 14 mm
15,5 cm - 6 1/8"	<b>57.33.17</b>	b = 17 mm

**Mod. Aachen**

a = 7 mm	20 cm - 8"	<b>57.33.07</b>	b = 8 mm
a = 10 mm	20 cm - 8"	<b>57.33.10</b>	b = 11 mm
a = 13 mm	20 cm - 8"	<b>57.33.13</b>	b = 14 mm
a = 16 mm	20 cm - 8"	<b>57.33.16</b>	b = 17 mm
a = 19 mm	20 cm - 8"	<b>57.33.19</b>	b = 20 mm
a = 22 mm	20 cm - 8"	<b>57.33.22</b>	b = 25 mm



biegbar  
malleable  
maleables  
malléables  
malleabili

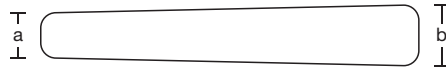

**Olivecrona**

a = 7 mm	18 cm - 7 1/8"	<b>57.31.09</b>	b = 9 mm
a = 11 mm	18 cm - 7 1/8"	<b>57.31.13</b>	b = 13 mm
a = 15 mm	18 cm - 7 1/8"	<b>57.31.18</b>	b = 18 mm
a = 18 mm	18 cm - 7 1/8"	<b>57.31.22</b>	b = 22 mm



**Olivecrona**

a = 7 mm	18 cm - 7 1/8"	<b>57.31.39</b>	b = 9 mm
a = 11 mm	18 cm - 7 1/8"	<b>57.31.43</b>	b = 13 mm
a = 15 mm	18 cm - 7 1/8"	<b>57.31.48</b>	b = 18 mm
a = 18 mm	18 cm - 7 1/8"	<b>57.31.52</b>	b = 22 mm



**Olivecrona**

a = 7 mm	18 cm - 7 1/8"	<b>57.31.59</b>	b = 9 mm
a = 11 mm	18 cm - 7 1/8"	<b>57.31.63</b>	b = 13 mm
a = 15 mm	18 cm - 7 1/8"	<b>57.31.68</b>	b = 18 mm
a = 18 mm	18 cm - 7 1/8"	<b>57.31.72</b>	b = 22 mm

**B07**

**Hirnspatelhalter (selbsthaltend)**  
**Brain Spatula Retractors (Self-Retaining)**  
**Separadores para espátulas cerebrales (autoestático)**  
**Ecarteurs pour des spatules cérébrales (autostatique)**  
**Divaricatori cerebrale (autostatico)**

Hirnspatelhalter (selbsthaltend) mit einem flexiblen Spannarm  
 Brain spatula retractor (self-retaining) with one flexible tension arm  
 Separador para espátulas cerebrales (autoestático) con uno brazo tensor flexible  
 Ecarteur pour des spatules cérébrales (autostatique) avec un bras tendeur flexibles  
 Divaricatore cerebrale (autostatico) con uno braccio tenditore flessibile

**Leyla**

<b>57.59.01</b>			
Satz bestehend aus: Set consisting of: Juego compuesto por: Jeu composé de: Set composto da:		<b>57.59.10</b> Flexibler Spannarm Flexible tension arm Brazo tensor flexible Bras tendeur flexible Braccio tenditore flessibile	1x
		<b>57.59.21</b> Fixiervorrichtung am Schädel für einen Spannarm Fixation base at skull for one tension arm Fijador al craneo para uno brazo tensor Base de fixation au crâne pour un bras tendeur Fissaggio al cranio per un braccio tenditore	1x
		<b>57.59.30</b> Halter für flache Hirnspatel Holder for flat brain spatulas Soporte para espátulas cerebrales planas Support pour des spatules cérébrales plates Sostegno per spatole cerebrali piate	1x





**Hirnspatelhalter (selbsthaltend)**  
**Brain Spatula Retractors (Self-Retaining)**  
**Separadores para espátulas cerebrales (autoestático)**  
**Ecarteurs pour des spatules cérébrales (autostatique)**  
**Divaricatori cerebrale (autostatico)**

**B07**

Hirnspatelhalter (selbsthaltend) mit zwei flexiblen Spannarmen  
 Brain spatula retractor (self-retaining) with two flexible arms  
 Separador para espátulas cerebrales (autoestático) con dos brazos tensores flexible  
 Ecarteur pour des spatules cérébrales (autostatique) avec deux bras tendeurs flexibles  
 Divaricatore cerebrale (autostatico) con due bracci tenditori flessibile



**Leyla**

<b>57.59.02</b>	
Satz bestehend aus: Set consisting of: Juego compuesto por: Jeu composé de: Set composto da:	 Leyla <b>57.59.10</b> Flexibler Spannarm Flexible tension arm Brazo tensor flexible Bras tendeur flexible Braccio tenditore flessibile 1x
	 Riechert <b>57.59.22</b> Fixiervorrichtung am Schädel für zwei Spannarme Fixation base at skull for two tension arms Fijador al craneo para dos brazos tensores Base de fixation au crâne pour deux bras tendeurs Fissaggio al cranio per due bracci tenditori 1x
	 Riechert <b>57.59.30</b> Halter für flache Hirnspatel Holder for flat brain spatulas Soporte para espátulas cerebrales planas Support pour des spatules cérébrales plates Sostegno per spatole cerebrali piate 1x



Einzelkomponente (siehe Seite 205)  
 Single components (see page 205)  
 Componentes individuales (véase página 205)  
 Composants individuels (voir page 205)  
 Componenti singoli (vedi pagina 205)

**B07****Hirnspatelhalter (Einzelkomponente)****Brain Spatula Retractors (Single Components)****Separadores para espátulas cerebrales (componentes individuales)****Ecarteurs pour des spatules cérébrales (composants individuels)****Divaricatori cerebrale (componenti singoli)**

Flexibler Spannarm  
Flexible tension arm  
Brazo tensor flexible  
Bras tendeur flexible  
Braccio tenditore flessibile

**Leyla****57.59.10**

Fixiervorrichtung am Schädel für einen Spannarm  
Fixation base at skull for one tension arm  
Fijador al craneo para uno brazo tensor  
Base de fixation au crâne pour un bras tendeur  
Fissaggio al cranio per un braccio tenditore

**Riechert****57.59.21**

Fixiervorrichtung am Schädel für zwei Spannarme  
Fixation base at skull for two tension arms  
Fijador al craneo para dos brazos tensores  
Base de fixation au crâne pour deux bras tendeurs  
Fissaggio al cranio per due bracci tenditori

**Riechert****57.59.22**

Halter für flache Hirnspatel  
Holder for flat brain spatulas  
Soporte para espátulas cerebrales planas  
Support pour des spatules cérébrales plates  
Sostegno per spatole cerebrali piate

**Riechert****57.59.30**

Die abgebildeten Instrumente stehen in keinem Größenverhältnis zueinander.

The instruments shown do not represent the actual dimensions.

Los instrumentos representados se relacionan entre sí en cualquier proporción de tamaño.

Les illustrations des instruments ne sont pas à l'échelle.

Gli strumenti illustrati non rappresentano le reali dimensioni.

Fixiervorrichtung am OP-Tisch oder "FIXIT"-Schädelklemme  
 Fixation base at operating table or "FIXIT" head rest  
 Fijador para la mesa operatoria o fijador craneal "FIXIT"  
 Base de fixation au table d'opération ou maintien crânien "FIXIT"  
 Fissaggio al tavolo operatorio o testiera "FIXIT"



**FIXIT**  
 HEAD REST SYSTEM



**57.59.26**

Halter für flache Hirnspatel mit Rundgriff  
 Holder for flat brain spatulas with round handle  
 Soporte para espátulas cerebrales planas con mango redondo  
 Support pour des spatules cérébrales plates avec manche rond  
 Sostegno per spatole cerebrali piatte con manico rotondo



**57.59.32**



Ø ≤ 5,5 mm



Auch geeignet für Instrumente mit Rundgriff  
 Also suitable for instruments with round handle  
 Recomendado también para instrumentos con mangos redondos  
 Convientent aussi pour instruments à manche rond  
 Anche adatto per strumenti con manico rotondo



Die abgebildeten Instrumente stehen in keinem Größenverhältnis zueinander.  
 The instruments shown do not represent the actual dimensions.  
 Los instrumentos representados se relacionan entre sí en cualquier proporción de tamaño.  
 Les illustrations des instruments ne sont pas à l'échelle.  
 Gli strumenti illustrati non rappresentano le reali dimensioni.

**B07****Haltearm (starr) für LEYLA Hirnspatelhalter****Holding Arm (rigid) for LEYLA Brain Retractors****Brazo de soporte (rigido) para LEYLA separador para espátulas cerebrales****Bras de support (rigide) pour LEYLA écarteur pour des spatules cérébrales****Braccio di supporto (rigido) per LEYLA divaricatore per spatole cerebrali**

21  
8  
20  
19  
18  
7  
17  
16  
6  
15  
14  
5  
13  
12  
4  
10  
9  
3  
7  
6  
2  
5  
4  
3  
1  
2  
1  
cm inch

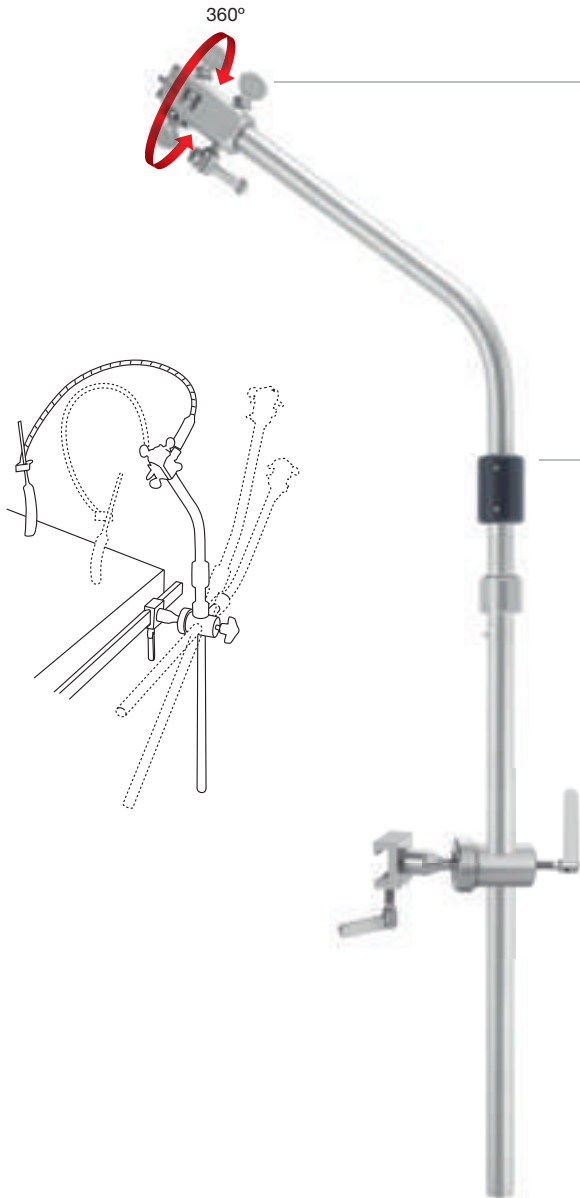
**57.59.42**

Kupplungskopf für maximal 5 flexible Spannarme  
Coupling head für maximum 5 flexible tension arms  
Cabeza de acoplamiento para máximo 5 brazos tensores flexibles  
Tête d'accouplement pour maximum 5 bras tendeurs flexibles  
Testa d'accoppiamento per massimo 5 bracci tenditori flessibili

**57.59.41**

Haltearm (starr), zweiteilig  
Holding arm (rigid), two parts  
Brazo de soporte (rigido), de dos partes  
Bras de support (rigide), en deux parties  
Braccio di supporto (rigido), da due pezzi

**57.59.43**

Tischfixierung mit Kugelgelenk  
Table fixation with ball joint  
Fijación de mesa con articulación esférica  
Fixation de table avec articulation sphérique  
Fissaggio per tavolo con articolazione sferica

**57.59.45**

Satz bestehend aus:	<b>57.59.41</b> Coupling head für maximum 5 flexible tension arms	1x
Set consisting of:	<b>57.59.42</b> Holding arm (rigid), two parts	1x
Juego compuesto por:	<b>57.59.43</b> Table fixation with ball joint	1x
Jeu composé de:		
Set composto da:		

Die Farbliche Kennzeichnung ermöglicht eine gute Identifikation der permanenten und temporären Clips. Die Clips sind aus TITAN oder PHYNOX hergestellt und besitzen eine MRT-Kompatibilität bis zu einer Feldstärke von 3 Tesla.

The colour markings allow good identification of permanent and temporary clips. The clips are made of TITANIUM or PHYNOX and have an MRT compatibility up to a field strength of 3 Tesla.

El código de color permite identificar fácilmente los clips permanentes y temporales. Los clips están fabricados en TITANIO o PHYNOX y son compatibles para TRM con intensidades de campo de hasta 3 Teslas.

Le code couleur utilisé permet de parfaitement identifier les clips temporaires et permanents. Les clips sont fabriqués en TITANE ou PHYNOX et sont compatibles avec les TRM jusqu'à une puissance de champ de 3 Tesla.

La marcatura colorata rende possibile una buona identificazione delle clip permanenti e temporanee. Le clip sono realizzate in TITANIO o PHYNOX e sono compatibili con la risonanza magnetica fino ad una intensità di campo magnetico di 3 Tesla.

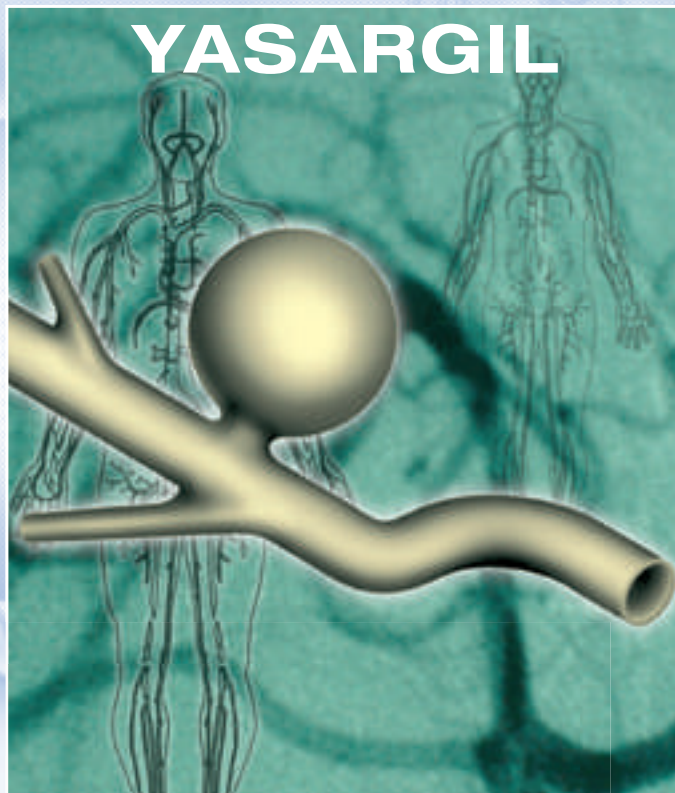

**B08****Clipausführungen: STANDARD und MINI****Typ of clip: STANDARD and MINI****Modelos de clip: STANDARD y MINI****Types de clips: STANDARD et MINI****Modello clip: STANDARD e MINI**

<b>STANDARD</b>			permanent permanent permanente permanent permanente
	<b>TITANIUM</b>	<b>PHYNOX</b>	
			temporär temporary temporal temporaire temporaneo

<b>STANDARD</b> gefenstert fenestrated fenestrado fenêtré fenestrato			permanent permanent permanente permanent permanente
	<b>TITANIUM</b>	<b>PHYNOX</b>	
			temporär temporary temporal temporaire temporaneo

<b>MINI</b>			permanent permanent permanente permanent permanente
	<b>TITANIUM</b>	<b>PHYNOX</b>	
			temporär temporary temporal temporaire temporaneo



Verpackungseinheit 1 Clip (nicht steril). Verpackung mit Clip-Identifikation.  
 Packing unit 1 clip (non-sterile). Packing with clip identification.  
 Paquete de 1 clip (no estéril). Paquete con identificación del clip.  
 Emballage unitaire de 1 clip (non stérile). Emballage avec identification du clip.  
 Confezione da 1 clip (non sterile). Confezione con identificazione della clip.



atraumatische Maulteile  
 atraumatic jaws  
 boca atraumatica  
 mors atraumatiques  
 morsi atraumatici

**YASARGIL**





**STANDARD**

**Zerebrovaskuläre Clips  
Cerebrovascular Clips  
Clips cerebrovascolari  
Clips vasculaires cérébraux  
Clip cerebrovascolari**

**B08**



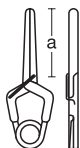

a = 7 mm

TITANIUM		PHYNOX	
 6,2 mm		 6,2 mm	
permanent	F = 150 g <b>58.60.08</b>	permanent	F = 150 g <b>58.54.08</b>
temporary	F = 110 g <b>58.60.58</b>	temporary	F = 110 g <b>58.54.58</b>



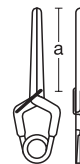

a = 9 mm

TITANIUM		PHYNOX	
 7,0 mm		 7,0 mm	
permanent	F = 180 g <b>58.60.10</b>	permanent	F = 180 g <b>58.54.10</b>
temporary	F = 90 g <b>58.60.60</b>	temporary	F = 90 g <b>58.54.60</b>



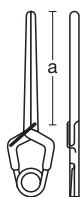

a = 11 mm

TITANIUM		PHYNOX	
 7,8 mm		 7,8 mm	
permanent	F = 180 g <b>58.60.12</b>	permanent	F = 180 g <b>58.54.12</b>
temporary	F = 90 g <b>58.60.62</b>	temporary	F = 90 g <b>58.54.62</b>



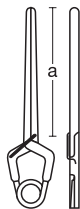

a = 15 mm

TITANIUM		PHYNOX	
 9,2 mm		 9,2 mm	
permanent	F = 200 g <b>58.60.16</b>	permanent	F = 200 g <b>58.54.16</b>
temporary	F = 90 g <b>58.60.66</b>	temporary	F = 90 g <b>58.54.66</b>



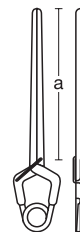

a = 17 mm

TITANIUM		PHYNOX	
 10,6 mm		 10,6 mm	
permanent	F = 200 g <b>58.60.18</b>	permanent	F = 200 g <b>58.54.18</b>
temporary	F = 90 g <b>58.60.67</b>	temporary	F = 90 g <b>58.54.67</b>





a = 20 mm

TITANIUM		PHYNOX	
 11,4 mm		 11,4 mm	
permanent	F = 200 g <b>58.60.21</b>	permanent	F = 200 g <b>58.54.21</b>
temporary	F = 110 g <b>58.60.71</b>	temporary	F = 110 g <b>58.54.71</b>





a = 25 mm

TITANIUM		PHYNOX	
 13,3 mm		 13,3 mm	
permanent	F = 200 g <b>58.60.26</b>	permanent	F = 200 g <b>58.54.26</b>
temporary	F = 110 g <b>58.60.72</b>	temporary	F = 110 g <b>58.54.72</b>



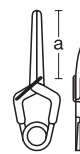

a = 7 mm

TITANIUM		PHYNOX	
 6,0 mm		 6,0 mm	
permanent	F = 110 g <b>58.61.08</b>	permanent	F = 110 g <b>58.55.08</b>
temporary	F = 150 g <b>58.61.58</b>	temporary	F = 150 g <b>58.55.58</b>



a = 9 mm

TITANIUM		PHYNOX	
 6,8 mm		 6,8 mm	
permanent	F = 180 g <b>58.61.10</b>	permanent	F = 180 g <b>58.55.10</b>
temporary	F = 90 g <b>58.61.60</b>	temporary	F = 90 g <b>58.55.60</b>

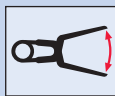

Öffnungsweite  
Opening width  
Abertura de ancho  
Largeur d'ouverture  
Larghezza dell'apertura







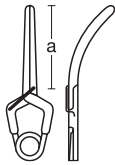

Schließkraft  
Closing pressure  
Fuerza de cierre  
Force de fermeture  
Forza di chiusura

**B08**

**Zerebrovaskuläre Clips**  
**Cerebrovascular Clips**  
**Clips cerebrovascular**  
**Clips vasculaires cérébraux**  
**Clip cerebrovascolari**





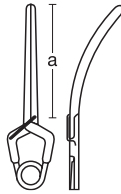

**YASARGIL****STANDARD**

a = 11 mm

TITANIUM		PHYNOX	
 7,5 mm		 7,5 mm	
permanent 	F = 180 g	permanent 	F = 180 g
<b>58.61.12</b>		<b>58.55.12</b>	
temporary 	F = 90 g	temporary 	F = 90 g
<b>58.61.64</b>		<b>58.55.64</b>	







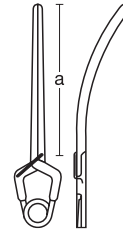

a = 15 mm

TITANIUM		PHYNOX	
 8,7 mm		 8,7 mm	
permanent 	F = 200 g	permanent 	F = 200 g
<b>58.61.16</b>		<b>58.55.16</b>	
temporary 	F = 110 g	temporary 	F = 110 g
<b>58.61.66</b>		<b>58.55.66</b>	







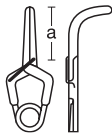

a = 20 mm

TITANIUM		PHYNOX	
 11,0 mm		 11,0 mm	
permanent 	F = 200 g	permanent 	F = 200 g
<b>58.61.20</b>		<b>58.55.20</b>	
temporary 	F = 90 g	temporary 	F = 90 g
<b>58.61.71</b>		<b>58.55.71</b>	







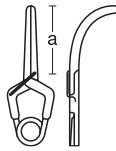

a = 7 mm

TITANIUM		PHYNOX	
 5,5 mm		 5,5 mm	
permanent 	F = 110 g	permanent 	F = 110 g
<b>58.61.28</b>		<b>58.55.28</b>	
temporary 	F = 150 g	temporary 	F = 150 g
<b>58.61.72</b>		<b>58.55.72</b>	







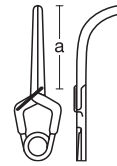

a = 9 mm

TITANIUM		PHYNOX	
 6,1 mm		 6,1 mm	
permanent 	F = 180 g	permanent 	F = 180 g
<b>58.61.30</b>		<b>58.55.30</b>	
temporary 	F = 110 g	temporary 	F = 110 g
<b>58.61.80</b>		<b>58.55.80</b>	







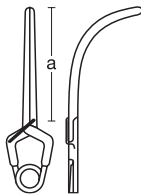

a = 11 mm

TITANIUM		PHYNOX	
 6,5 mm		 6,5 mm	
permanent 	F = 180 g	permanent 	F = 180 g
<b>58.61.32</b>		<b>58.55.32</b>	
temporary 	F = 110 g	temporary 	F = 110 g
<b>58.61.81</b>		<b>58.55.81</b>	







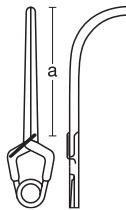

a = 15 mm

TITANIUM		PHYNOX	
 7,4 mm		 7,4 mm	
permanent 	F = 110 g	permanent 	F = 110 g
<b>58.61.36</b>		<b>58.55.36</b>	
temporary 	F = 200 g	temporary 	F = 200 g
<b>58.61.86</b>		<b>58.55.86</b>	



a = 17 mm

TITANIUM		PHYNOX	
 9,9 mm		 9,9 mm	
permanent 	F = 200 g	permanent 	F = 110 g
<b>58.61.17</b>		<b>58.55.17</b>	
temporary 	F = 90 g	temporary 	F = 90 g
<b>58.61.91</b>		<b>58.55.91</b>	

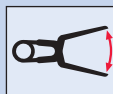

Öffnungsweite  
 Opening width  
 Abertura de ancho  
 Largeur d'ouverture  
 Larghezza dell'apertura

**F**

Schließkraft  
 Closing pressure  
 Fuerza de cierre  
 Force de fermeture  
 Forza di chiusura



**YASARGIL**





**STANDARD**

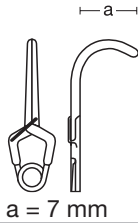

**Zerebrovaskuläre Clips  
Cerebrovascular Clips  
Clips cerebrovascular  
Clips vasculaires cérébraux  
Clip cerebrovascolari**

**B08**



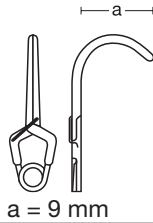

TITANIUM		PHYNOX	
 5,4 mm		 5,4 mm	
permanent	F = 180 g <b>58.61.37</b>	permanent	F = 180 g <b>58.55.37</b>
temporary	F = 110 g <b>58.61.92</b>	temporary	F = 110 g <b>58.55.92</b>



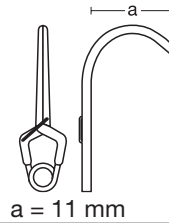

TITANIUM		PHYNOX	
 5,8 mm		 5,8 mm	
permanent	F = 180 g <b>58.61.38</b>	permanent	F = 180 g <b>58.55.38</b>
temporary	F = 110 g <b>58.61.94</b>	temporary	F = 110 g <b>58.55.94</b>



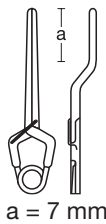

TITANIUM		PHYNOX	
 6,2 mm		 6,2 mm	
permanent	F = 180 g <b>58.61.39</b>	permanent	F = 180 g <b>58.55.39</b>
temporary	F = 110 g <b>58.61.95</b>	temporary	F = 110 g <b>58.55.95</b>



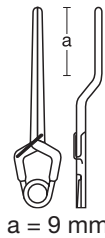

TITANIUM		PHYNOX	
 7,9 mm		 7,9 mm	
permanent	F = 200 g <b>58.61.43</b>	permanent	F = 200 g <b>58.55.43</b>
temporary	F = 90 g <b>58.63.06</b>	temporary	F = 90 g <b>58.59.06</b>



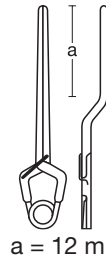

TITANIUM		PHYNOX	
 8,7 mm		 8,7 mm	
permanent	F = 200 g <b>58.61.45</b>	permanent	F = 200 g <b>58.55.45</b>
temporary	F = 90 g <b>58.63.09</b>	temporary	F = 90 g <b>58.59.09</b>



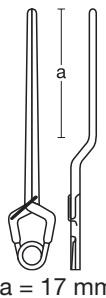

TITANIUM		PHYNOX	
 10,2 mm		 10,2 mm	
permanent	F = 200 g <b>58.61.44</b>	permanent	F = 200 g <b>58.55.44</b>
temporary	F = 90 g <b>58.63.12</b>	temporary	F = 90 g <b>58.59.12</b>

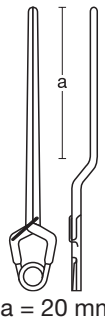

TITANIUM		PHYNOX	
 11,9 mm		 11,9 mm	
permanent	F = 180 g <b>58.61.47</b>	permanent	F = 180 g <b>58.55.47</b>
temporary	F = 90 g <b>58.63.17</b>	temporary	F = 90 g <b>58.59.17</b>



TITANIUM		PHYNOX	
 13,0 mm		 13,0 mm	
permanent	F = 180 g <b>58.61.46</b>	permanent	F = 180 g <b>58.55.46</b>
temporary	F = 90 g <b>58.63.20</b>	temporary	F = 90 g <b>58.59.20</b>

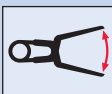

Öffnungsweite  
Opening width  
Abertura de ancho  
Largeur d'ouverture  
Larghezza dell'apertura







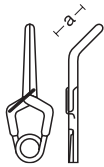

Schließkraft  
Closing pressure  
Fuerza de cierre  
Force de fermeture  
Forza di chiusura

**B08**

**Zerebrovaskuläre Clips**  
**Cerebrovascular Clips**  
**Clips cerebrovascular**  
**Clips vasculaires cérébraux**  
**Clip cerebrovascolari**





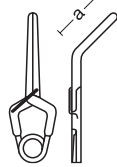

**YASARGIL****STANDARD**

a = 5 mm

TITANIUM		PHYNIX	
 6,2 mm		 6,2 mm	
permanent 	F = 200 g <b>58.61.50</b>	permanent 	F = 200 g <b>58.55.50</b>
temporary 	F = 110 g <b>58.61.85</b>	temporary 	F = 110 g <b>58.59.85</b>







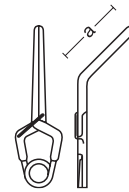

a = 7 mm

TITANIUM		PHYNIX	
 6,5 mm		 6,5 mm	
permanent 	F = 200 g <b>58.61.51</b>	permanent 	F = 200 g <b>58.55.51</b>
temporary 	F = 110 g <b>58.61.87</b>	temporary 	F = 110 g <b>58.55.87</b>







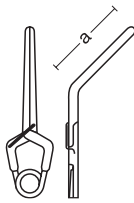

a = 9 mm

TITANIUM		PHYNIX	
 7,8 mm		 7,8 mm	
permanent 	F = 110 g <b>58.61.48</b>	permanent 	F = 110 g <b>58.55.48</b>
temporary 	F = 200 g <b>58.61.89</b>	temporary 	F = 200 g <b>58.55.89</b>







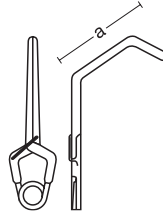

a = 11 mm

TITANIUM		PHYNIX	
 8,4 mm		 8,4 mm	
permanent 	F = 200 g <b>58.61.52</b>	permanent 	F = 200 g <b>58.55.52</b>
temporary 	F = 110 g <b>58.61.90</b>	temporary 	F = 110 g <b>58.55.90</b>







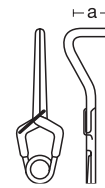

a = 13 mm

TITANIUM		PHYNIX	
 7,5 mm		 7,5 mm	
permanent 	F = 200 g <b>58.61.96</b>	permanent 	F = 200 g <b>58.55.96</b>
temporary 	F = 90 g <b>58.61.93</b>	temporary 	F = 90 g <b>58.55.93</b>







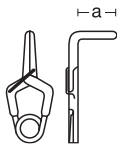

a = 5 mm

TITANIUM		PHYNIX	
 7,2 mm		 7,2 mm	
permanent 	F = 200 g <b>58.61.65</b>	permanent 	F = 200 g <b>58.55.65</b>
temporary 	F = 90 g <b>58.65.25</b>	temporary 	F = 90 g <b>58.63.25</b>







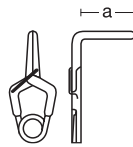

a = 5 mm

TITANIUM		PHYNIX	
 5,6 mm		 5,6 mm	
permanent 	F = 200 g <b>58.61.55</b>	permanent 	F = 200 g <b>58.55.55</b>
temporary 	F = 130 g <b>58.65.05</b>	temporary 	F = 130 g <b>58.63.05</b>







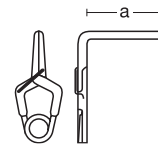

a = 7 mm

TITANIUM		PHYNIX	
 5,6 mm		 5,6 mm	
permanent 	F = 200 g <b>58.61.49</b>	permanent 	F = 200 g <b>58.55.49</b>
temporary 	F = 130 g <b>58.65.07</b>	temporary 	F = 130 g <b>58.63.07</b>



a = 10 mm

TITANIUM		PHYNIX	
 5,6 mm		 5,6 mm	
permanent 	F = 200 g <b>58.61.57</b>	permanent 	F = 200 g <b>58.55.57</b>
temporary 	F = 130 g <b>58.65.10</b>	temporary 	F = 130 g <b>58.63.10</b>

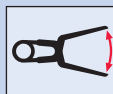

Öffnungsweite  
Opening width  
Abertura de ancho  
Largeur d'ouverture  
Larghezza dell'apertura

**F**

Schließkraft  
Closing pressure  
Fuerza de cierre  
Force de fermeture  
Forza di chiusura

**YASARGIL  
STANDARD**

**Zerebrovaskuläre Clips  
Cerebrovascular Clips  
Clips cerebrovasculari  
Clips vasculaires cérébraux  
Clip cerebrovascolari**

**B08**

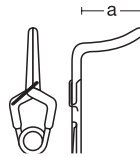

a = 8 mm

TITANIUM		PHYNOX	
5,4 mm		5,4 mm	
permanent	F = 200 g <b>58.61.62</b>	permanent	F = 200 g <b>58.55.62</b>
temporary	F = 130 g <b>58.65.08</b>	temporary	F = 130 g <b>58.63.08</b>

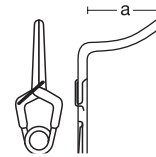

a = 10 mm

TITANIUM		PHYNOX	
5,6 mm		5,6 mm	
permanent	F = 200 g <b>58.61.63</b>	permanent	F = 200 g <b>58.55.63</b>
temporary	F = 130 g <b>58.65.21</b>	temporary	F = 130 g <b>58.63.21</b>

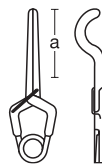

a = 9 mm

TITANIUM		PHYNOX	
7,2 mm		7,2 mm	
permanent	F = 200 g <b>58.61.68</b>	permanent	F = 200 g <b>58.55.68</b>
temporary	F = 90 g <b>58.65.29</b>	temporary	F = 90 g <b>58.63.29</b>

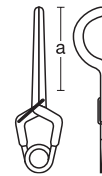

a = 11 mm

TITANIUM		PHYNOX	
8,2 mm		8,2 mm	
permanent	F = 200 g <b>58.61.67</b>	permanent	F = 200 g <b>58.55.67</b>
temporary	F = 90 g <b>58.65.31</b>	temporary	F = 90 g <b>58.63.31</b>

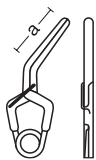

a = 7 mm

TITANIUM		PHYNOX	
5,7 mm		5,7 mm	
permanent	F = 200 g <b>58.61.40</b>	permanent	F = 200 g <b>58.55.40</b>
temporary	F = 90 g <b>58.65.37</b>	temporary	F = 90 g <b>58.63.37</b>

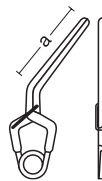

a = 11 mm

TITANIUM		PHYNOX	
8,0 mm		8,0 mm	
permanent	F = 200 g <b>58.61.41</b>	permanent	F = 200 g <b>58.55.41</b>
temporary	F = 90 g <b>58.65.41</b>	temporary	F = 90 g <b>58.63.41</b>

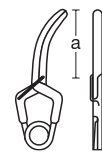

a = 9 mm

TITANIUM		PHYNOX	
6,2 mm		6,2 mm	
permanent	F = 200 g <b>58.61.42</b>	permanent	F = 200 g <b>58.55.42</b>
temporary	F = 90 g <b>58.65.49</b>	temporary	F = 90 g <b>58.63.49</b>

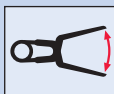

Öffnungsweite  
Opening width  
Abertura de ancho  
Largeur d'ouverture  
Larghezza dell'apertura



Schließkraft  
Closing pressure  
Fuerza de cierre  
Force de fermeture  
Forza di chiusura

**B08**





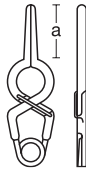

**Zerebrovaskuläre Clips**  
**Cerebrovascular Clips**  
**Clips cerebrovascular**  
**Clips vasculaires cérébraux**  
**Clip cerebrovascolari**

gefenstert  
fenestrated  
fenestrado  
fenêtré  
fenestrato

**YASARGIL**  
**3,5 mm**  
**STANDARD**









a = 7 mm

	TITANIUM	PHYNOX
	 7,4 mm	 7,4 mm
permanent	 F = 150 g <b>58.59.50</b>	 F = 150 g <b>58.53.50</b>
temporary	 F = 110 g <b>58.64.07</b>	 F = 110 g <b>58.58.07</b>







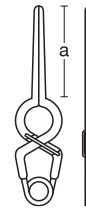

a = 9 mm

	TITANIUM	PHYNOX
	 8,4 mm	 8,4 mm
permanent	 F = 150 g <b>58.59.51</b>	 F = 150 g <b>58.53.51</b>
temporary	 F = 110 g <b>58.64.09</b>	 F = 110 g <b>58.58.09</b>







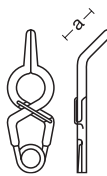

a = 12 mm

	TITANIUM	PHYNOX
	 9,6 mm	 9,6 mm
permanent	 F = 180 g <b>58.59.52</b>	 F = 180 g <b>58.53.52</b>
temporary	 F = 90 g <b>58.64.12</b>	 F = 90 g <b>58.58.12</b>







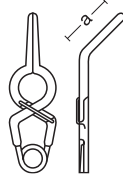

a = 5 mm

	TITANIUM	PHYNOX
	 5,8 mm	 5,8 mm
permanent	 F = 150 g <b>58.59.53</b>	 F = 150 g <b>58.53.53</b>
temporary	 F = 110 g <b>58.64.15</b>	 F = 110 g <b>58.58.15</b>







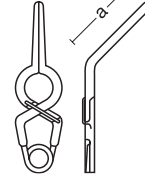

a = 7 mm

	TITANIUM	PHYNOX
	 6,5 mm	 6,5 mm
permanent	 F = 150 g <b>58.59.54</b>	 F = 150 g <b>58.53.54</b>
temporary	 F = 110 g <b>58.64.17</b>	 F = 110 g <b>58.58.17</b>







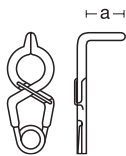

a = 11 mm

	TITANIUM	PHYNOX
	 7,2 mm	 7,2 mm
permanent	 F = 180 g <b>58.59.55</b>	 F = 180 g <b>58.53.55</b>
temporary	 F = 110 g <b>58.64.21</b>	 F = 110 g <b>58.58.21</b>







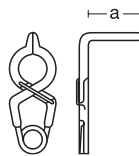

a = 5 mm

	TITANIUM	PHYNOX
	 4,9 mm	 4,9 mm
permanent	 F = 150 g <b>58.59.56</b>	 F = 150 g <b>58.53.56</b>
temporary	 F = 110 g <b>58.64.25</b>	 F = 110 g <b>58.58.25</b>







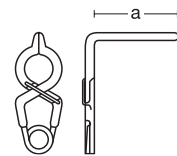

a = 7 mm

	TITANIUM	PHYNOX
	 4,9 mm	 4,9 mm
permanent	 F = 150 g <b>58.59.57</b>	 F = 150 g <b>58.53.57</b>
temporary	 F = 110 g <b>58.64.27</b>	 F = 110 g <b>58.58.27</b>



a = 11 mm

	TITANIUM	PHYNOX
	 4,9 mm	 4,9 mm
permanent	 F = 180 g <b>58.59.58</b>	 F = 180 g <b>58.53.58</b>
temporary	 F = 110 g <b>58.64.31</b>	 F = 110 g <b>58.58.31</b>

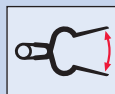

Öffnungsweite  
Opening width  
Abertura de ancho  
Largeur d'ouverture  
Larghezza dell'apertura

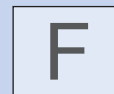

Schließkraft  
Closing pressure  
Fuerza de cierre  
Force de fermeture  
Forza di chiusura

**YASARGIL**  
**5,0 mm**  
**STANDARD**

gefenstert  
fenestrado  
fenêtré  
fenestrato

**Zerebrovaskuläre Clips**  
**Cerebrovascular Clips**  
**Clips cerebrovascular**  
**Clips vasculaires cérébraux**  
**Clip cerebrovascolari**

**B08**

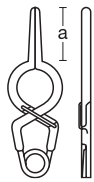

a = 7 mm

	TITANIUM	PHYNOX
	7,9 mm	7,9 mm
permanent	F = 150 g <b>58.59.60</b>	F = 150 g <b>58.53.60</b>
temporary	F = 110 g <b>58.64.37</b>	F = 110 g <b>58.58.37</b>

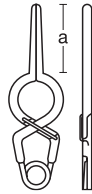

a = 9 mm

	TITANIUM	PHYNOX
	9,1 mm	9,1 mm
permanent	F = 150 g <b>58.59.61</b>	F = 150 g <b>58.53.61</b>
temporary	F = 100 g <b>58.64.39</b>	F = 100 g <b>58.58.39</b>

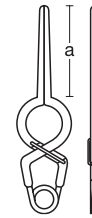

a = 12 mm

	TITANIUM	PHYNOX
	10,3 mm	10,3 mm
permanent	F = 180 g <b>58.59.62</b>	F = 180 g <b>58.53.62</b>
temporary	F = 90 g <b>58.64.42</b>	F = 90 g <b>58.58.42</b>

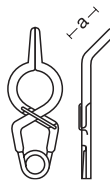

a = 5 mm

	TITANIUM	PHYNOX
	6,5 mm	6,5 mm
permanent	F = 150 g <b>58.59.63</b>	F = 150 g <b>58.53.63</b>
temporary	F = 110 g <b>58.64.45</b>	F = 110 g <b>58.58.45</b>

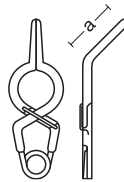

a = 7 mm

	TITANIUM	PHYNOX
	7,2 mm	7,2 mm
permanent	F = 150 g <b>58.59.64</b>	F = 150 g <b>58.53.64</b>
temporary	F = 110 g <b>58.64.47</b>	F = 110 g <b>58.58.47</b>

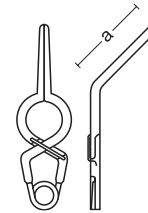

a = 11 mm

	TITANIUM	PHYNOX
	7,8 mm	7,8 mm
permanent	F = 180 g <b>58.59.65</b>	F = 180 g <b>58.53.65</b>
temporary	F = 110 g <b>58.64.51</b>	F = 110 g <b>58.58.51</b>

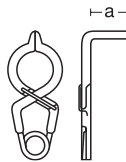

a = 5 mm

	TITANIUM	PHYNOX
	5,5 mm	5,5 mm
permanent	F = 150 g <b>58.59.66</b>	F = 150 g <b>58.53.66</b>
temporary	F = 110 g <b>58.64.55</b>	F = 110 g <b>58.58.55</b>

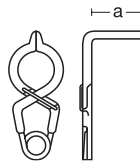

a = 7 mm

	TITANIUM	PHYNOX
	5,5 mm	5,5 mm
permanent	F = 150 g <b>58.59.67</b>	F = 150 g <b>58.53.67</b>
temporary	F = 110 g <b>58.64.57</b>	F = 110 g <b>58.58.57</b>

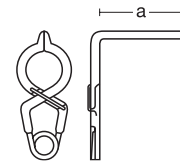

a = 11 mm

	TITANIUM	PHYNOX
	5,5 mm	5,5 mm
permanent	F = 180 g <b>58.59.68</b>	F = 180 g <b>58.53.68</b>
temporary	F = 90 g <b>58.64.61</b>	F = 90 g <b>58.58.61</b>

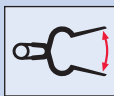

Öffnungsweite  
Opening width  
Abertura de ancho  
Largeur d'ouverture  
Larghezza dell'apertura



Schließkraft  
Closing pressure  
Fuerza de cierre  
Force de fermeture  
Forza di chiusura



**Zerebrovaskuläre Clips**  
**Cerebrovascular Clips**  
**Clips cerebrovascular**  
**Clips vasculaires cérébraux**  
**Clip cerebrovascolari**

gefenstert  
fenestrated  
fenestrado  
fenêtré  
fenestrato

**YASARGIL**  
**5,0 mm**  
**STANDARD**

**B08**

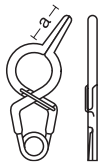

a = 5 mm

TITANIUM		PHYNOX	
7,0 mm		7,0 mm	
permanent	F = 150 g	permanent	F = 150 g
	<b>58.59.81</b>		<b>58.53.81</b>
temporary	F = 110 g	temporary	F = 110 g
	<b>58.47.25</b>		<b>58.41.25</b>

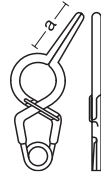

a = 7 mm

TITANIUM		PHYNOX	
7,8 mm		7,8 mm	
permanent	F = 150 g	permanent	F = 150 g
	<b>58.59.82</b>		<b>58.53.82</b>
temporary	F = 110 g	temporary	F = 110 g
	<b>58.47.27</b>		<b>58.41.27</b>

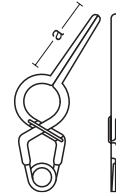

a = 10 mm

TITANIUM		PHYNOX	
8,8 mm		8,8 mm	
permanent	F = 150 g	permanent	F = 150 g
	<b>58.59.83</b>		<b>58.53.83</b>
temporary	F = 110 g	temporary	F = 110 g
	<b>58.47.30</b>		<b>58.41.30</b>

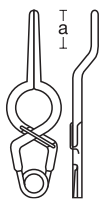

a = 5 mm

TITANIUM		PHYNOX	
7,9 mm		7,9 mm	
permanent	F = 150 g	permanent	F = 150 g
	<b>58.59.69</b>		<b>58.53.69</b>
temporary	F = 90 g	temporary	F = 90 g
	<b>58.64.65</b>		<b>58.58.65</b>

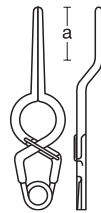

a = 7 mm

TITANIUM		PHYNOX	
8,8 mm		8,8 mm	
permanent	F = 150 g	permanent	F = 150 g
	<b>58.59.70</b>		<b>58.53.70</b>
temporary	F = 90 g	temporary	F = 90 g
	<b>58.64.67</b>		<b>58.58.67</b>

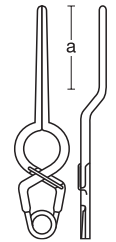

a = 11 mm

TITANIUM		PHYNOX	
10,0 mm		10,0 mm	
permanent	F = 180 g	permanent	F = 180 g
	<b>58.59.71</b>		<b>58.53.71</b>
temporary	F = 90 g	temporary	F = 90 g
	<b>58.64.71</b>		<b>58.58.71</b>



a = 5 mm

TITANIUM		PHYNOX	
5,8 mm		5,8 mm	
permanent	F = 150 g	permanent	F = 150 g
	<b>58.59.74</b>		<b>58.53.74</b>
temporary	F = 110 g	temporary	F = 110 g
	<b>58.47.05</b>		<b>58.41.05</b>

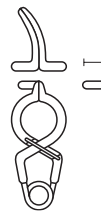

a = 7 mm

TITANIUM		PHYNOX	
5,8 mm		5,8 mm	
permanent	F = 150 g	permanent	F = 150 g
	<b>58.59.75</b>		<b>58.53.75</b>
temporary	F = 110 g	temporary	F = 110 g
	<b>58.47.07</b>		<b>58.41.07</b>

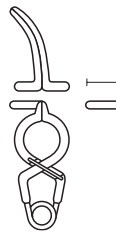

a = 11 mm

TITANIUM		PHYNOX	
5,8 mm		5,8 mm	
permanent	F = 150 g	permanent	F = 150 g
	<b>58.59.76</b>		<b>58.53.76</b>
temporary	F = 110 g	temporary	F = 110 g
	<b>58.47.10</b>		<b>58.41.10</b>

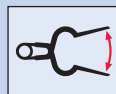

Öffnungsweite  
Opening width  
Abertura de ancho  
Largeur d'ouverture  
Larghezza dell'apertura

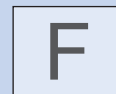

Schließkraft  
Closing pressure  
Fuerza de cierre  
Force de fermeture  
Forza di chiusura

**YASARGIL**  
**5,0 mm**  
**STANDARD**

gefenstert  
fenestrado  
fenêtré  
fenestrato

**Zerebrovaskuläre Clips**  
**Cerebrovascular Clips**  
**Clips cerebrovascular**  
**Clips vasculaires cérébraux**  
**Clip cerebrovascolari**

**B08**

<p>a = 5 mm</p>		<p>a = 7 mm</p>		<p>a = 10 mm</p>	
<b>TITANIUM</b> 5,8 mm	<b>PHYNOX</b> 5,8 mm	<b>TITANIUM</b> 5,8 mm	<b>PHYNOX</b> 5,8 mm	<b>TITANIUM</b> 5,8 mm	<b>PHYNOX</b> 5,8 mm
permanent F = 150 g <b>58.59.77</b>	permanent F = 150 g <b>58.53.77</b>	permanent F = 150 g <b>58.59.78</b>	permanent F = 150 g <b>58.53.78</b>	permanent F = 150 g <b>58.59.79</b>	permanent F = 150 g <b>58.53.79</b>
temporary F = 110 g <b>58.47.15</b>	temporary F = 110 g <b>58.41.15</b>	temporary F = 110 g <b>58.47.17</b>	temporary F = 110 g <b>58.41.17</b>	temporary F = 110 g <b>58.47.20</b>	temporary F = 110 g <b>58.41.20</b>

<p>a = 5 mm</p>		<p>a = 7 mm</p>	
<b>TITANIUM</b> 5,8 mm	<b>PHYNOX</b> 5,8 mm	<b>TITANIUM</b> 6,2 mm	<b>PHYNOX</b> 6,2 mm
permanent F = 150 g <b>58.59.86</b>	permanent F = 150 g <b>58.53.86</b>	permanent F = 150 g <b>58.59.87</b>	permanent F = 150 g <b>58.53.87</b>
temporary F = 110 g <b>58.47.35</b>	temporary F = 110 g <b>58.41.35</b>	temporary F = 110 g <b>58.47.37</b>	temporary F = 110 g <b>58.41.37</b>

<p>a = 5 mm</p>		<p>a = 7 mm</p>	
<b>TITANIUM</b> 5,8 mm	<b>PHYNOX</b> 5,8 mm	<b>TITANIUM</b> 6,2 mm	<b>PHYNOX</b> 6,2 mm
permanent F = 150 g <b>58.59.88</b>	permanent F = 150 g <b>58.53.88</b>	permanent F = 150 g <b>58.59.89</b>	permanent F = 150 g <b>58.53.89</b>
temporary F = 110 g <b>58.47.45</b>	temporary F = 110 g <b>58.41.45</b>	temporary F = 110 g <b>58.47.47</b>	temporary F = 110 g <b>58.41.47</b>

Öffnungsweite  
Opening width  
Abertura de ancho  
Largeur d'ouverture  
Larghezza dell'apertura

**F** Schließkraft  
Closing pressure  
Fuerza de cierre  
Force de fermeture  
Forza di chiusura



Zerebrovaskuläre Clips  
Cerebrovascular Clips  
Clips cerebrovascular  
Clips vasculaires cérébraux  
Clip cerebrovascolari

gefenstert  
fenestrated  
fenestrado  
fenêtré  
fenestrato

**YASARGIL**  
**5,0 mm**  
**STANDARD**

**B08**

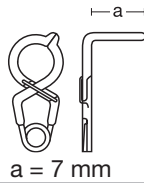
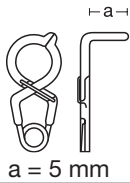

TITANIUM		PHYNOX	
	5,6 mm		5,6 mm
permanent	F = 150 g	permanent	F = 150 g
	<b>58.59.91</b>		<b>58.53.91</b>
temporary	F = 110 g	temporary	F = 110 g
	<b>58.47.55</b>		<b>58.41.55</b>

TITANIUM		PHYNOX	
	5,6 mm		5,6 mm
permanent	F = 150 g	permanent	F = 150 g
	<b>58.59.92</b>		<b>58.53.92</b>
temporary	F = 110 g	temporary	F = 110 g
	<b>58.47.57</b>		<b>58.41.57</b>

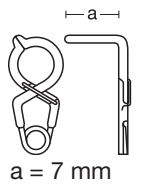
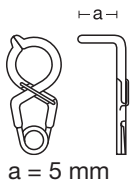

TITANIUM		PHYNOX	
	5,6 mm		5,6 mm
permanent	F = 150 g	permanent	F = 150 g
	<b>58.59.93</b>		<b>58.53.93</b>
temporary	F = 110 g	temporary	F = 110 g
	<b>58.47.65</b>		<b>58.41.65</b>

TITANIUM		PHYNOX	
	5,6 mm		5,6 mm
permanent	F = 150 g	permanent	F = 150 g
	<b>58.59.94</b>		<b>58.53.94</b>
temporary	F = 110 g	temporary	F = 110 g
	<b>58.47.67</b>		<b>58.41.67</b>

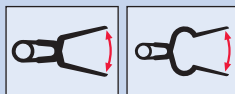

Öffnungsweite  
Opening width  
Abertura de ancho  
Largeur d'ouverture  
Larghezza dell'apertura

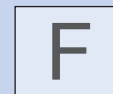

Schließkraft  
Closing pressure  
Fuerza de cierre  
Force de fermeture  
Forza di chiusura



**YASARGIL**



**MINI**

**Zerebrovaskuläre Clips  
Cerebrovascular Clips  
Clips cerebrovascolari  
Clips vasculaires cérébraux  
Clip cerebrovascolari**

**B08**



a = 3 mm

TITANIUM		PHYNOX	
3,3 mm		3,3 mm	
permanent	F = 110 g <b>58.42.03</b>	permanent	F = 110 g <b>58.56.03</b>
temporary	F = 90 g <b>58.42.53</b>	temporary	F = 90 g <b>58.56.53</b>

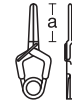

a = 5 mm

TITANIUM		PHYNOX	
4,0 mm		4,0 mm	
permanent	F = 110 g <b>58.42.05</b>	permanent	F = 110 g <b>58.56.05</b>
temporary	F = 70 g <b>58.42.55</b>	temporary	F = 70 g <b>58.56.55</b>



a = 3 mm

TITANIUM		PHYNOX	
3,3 mm		3,3 mm	
permanent	F = 110 g <b>58.42.04</b>	permanent	F = 110 g <b>58.56.04</b>
temporary	F = 90 g <b>58.42.63</b>	temporary	F = 90 g <b>58.56.63</b>



a = 5 mm

TITANIUM		PHYNOX	
4,0 mm		4,0 mm	
permanent	F = 110 g <b>58.42.06</b>	permanent	F = 110 g <b>58.56.06</b>
temporary	F = 70 g <b>58.42.65</b>	temporary	F = 70 g <b>58.56.65</b>

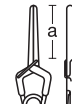

a = 7 mm

TITANIUM		PHYNOX	
4,6 mm		4,6 mm	
permanent	F = 110 g <b>58.42.07</b>	permanent	F = 110 g <b>58.56.07</b>
temporary	F = 70 g <b>58.42.58</b>	temporary	F = 70 g <b>58.56.58</b>



a = 3 mm

TITANIUM		PHYNOX	
3,2 mm		3,2 mm	
permanent	F = 110 g <b>58.43.03</b>	permanent	F = 110 g <b>58.57.03</b>
temporary	F = 90 g <b>58.43.53</b>	temporary	F = 90 g <b>58.57.53</b>



a = 4 mm

TITANIUM		PHYNOX	
3,8 mm		3,8 mm	
permanent	F = 110 g <b>58.43.05</b>	permanent	F = 110 g <b>58.57.05</b>
temporary	F = 70 g <b>58.43.55</b>	temporary	F = 70 g <b>58.57.55</b>



a = 4 mm

TITANIUM		PHYNOX	
3,6 mm		3,6 mm	
permanent	F = 110 g <b>58.43.15</b>	permanent	F = 110 g <b>58.57.15</b>
temporary	F = 80 g <b>58.43.65</b>	temporary	F = 80 g <b>58.57.65</b>



a = 4 mm

TITANIUM		PHYNOX	
3,6 mm		3,6 mm	
permanent	F = 110 g <b>58.43.08</b>	permanent	F = 110 g <b>58.57.08</b>
temporary	F = 80 g <b>58.43.57</b>	temporary	F = 80 g <b>58.57.57</b>



a = 5 mm

TITANIUM		PHYNOX	
3,8 mm		3,8 mm	
permanent	F = 110 g <b>58.43.06</b>	permanent	F = 110 g <b>58.57.06</b>
temporary	F = 70 g <b>58.43.59</b>	temporary	F = 70 g <b>58.57.59</b>



a = 7 mm

TITANIUM		PHYNOX	
4,4 mm		4,4 mm	
permanent	F = 110 g <b>58.43.07</b>	permanent	F = 110 g <b>58.57.07</b>
temporary	F = 70 g <b>58.43.58</b>	temporary	F = 70 g <b>58.57.58</b>

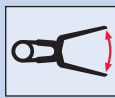

Öffnungsweite  
Opening width  
Abertura de ancho  
Largeur d'ouverture  
Larghezza dell'apertura



Schließkraft  
Closing pressure  
Fuerza de cierre  
Force de fermeture  
Forza di chiusura

**B08**

**Zerebrovaskuläre Clips**  
**Cerebrovascular Clips**  
**Clips cerebrovascular**  
**Clips vasculaires cérébraux**  
**Clip cerebrovascolari**

**YASARGIL****MINI**

a = 4 mm

TITANIUM		PHYNOX	
	3,6 mm		3,6 mm
permanent	F = 110 g <b>58.43.09</b>	permanent	F = 110 g <b>58.57.09</b>
temporary	F = 80 g <b>58.43.61</b>	temporary	F = 80 g <b>58.57.61</b>

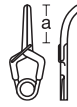

a = 5 mm

TITANIUM		PHYNOX	
	4,0 mm		4,0 mm
permanent	F = 110 g <b>58.43.10</b>	permanent	F = 110 g <b>58.57.10</b>
temporary	F = 70 g <b>58.43.63</b>	temporary	F = 70 g <b>58.57.63</b>

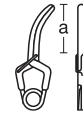

a = 6 mm

TITANIUM		PHYNOX	
	6,0 mm		6,0 mm
permanent	F = 130 g <b>58.43.41</b>	permanent	F = 130 g <b>58.57.41</b>
temporary	F = 70 g <b>58.43.70</b>	temporary	F = 70 g <b>58.57.70</b>



a = 4 mm

TITANIUM		PHYNOX	
	3,5 mm		3,5 mm
permanent	F = 110 g <b>58.43.16</b>	permanent	F = 110 g <b>58.57.16</b>
temporary	F = 80 g <b>58.43.67</b>	temporary	F = 80 g <b>58.57.67</b>

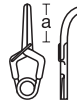

a = 5 mm

TITANIUM		PHYNOX	
	4,0 mm		4,0 mm
permanent	F = 110 g <b>58.43.17</b>	permanent	F = 110 g <b>58.57.17</b>
temporary	F = 70 g <b>58.43.68</b>	temporary	F = 70 g <b>58.57.68</b>

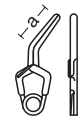

a = 5 mm

TITANIUM		PHYNOX	
	3,5 mm		3,5 mm
permanent	F = 130 g <b>58.43.40</b>	permanent	F = 130 g <b>58.57.40</b>
temporary	F = 70 g <b>58.43.69</b>	temporary	F = 70 g <b>58.57.69</b>

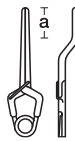

a = 4 mm

TITANIUM		PHYNOX	
	7,0 mm		7,0 mm
permanent	F = 130 g <b>58.43.43</b>	permanent	F = 130 g <b>58.57.43</b>
temporary	F = 70 g <b>58.43.71</b>	temporary	F = 70 g <b>58.57.71</b>

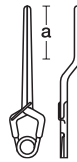

a = 7 mm

TITANIUM		PHYNOX	
	5,7 mm		5,7 mm
permanent	F = 130 g <b>58.43.42</b>	permanent	F = 130 g <b>58.57.42</b>
temporary	F = 70 g <b>58.43.72</b>	temporary	F = 70 g <b>58.57.72</b>

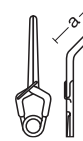

a = 7 mm

TITANIUM		PHYNOX	
	4,5 mm		4,5 mm
permanent	F = 130 g <b>58.43.48</b>	permanent	F = 130 g <b>58.57.48</b>
temporary	F = 70 g <b>58.43.73</b>	temporary	F = 70 g <b>58.57.73</b>

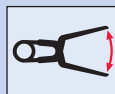

Öffnungsweite  
Opening width  
Abertura de ancho  
Largeur d'ouverture  
Larghezza dell'apertura

**F**

Schließkraft  
Closing pressure  
Fuerza de cierre  
Force de fermeture  
Forza di chiusura

**Anlegezangen und Zubehör**  
**Applying Forceps and Accessories**  
**Pinzas para aplicar y accesorios**  
**Pinces à appliquer et accessoires**  
**Pinze per applicare ed accessori**

**B08**



Maul mit drehbarer Clip-Aufnahme  
 Rotatable jaw for clip application  
 Boca con acogida giratoria para clips  
 Mors avec prise pivotante pour clips  
 Morso da presa girevole per clip

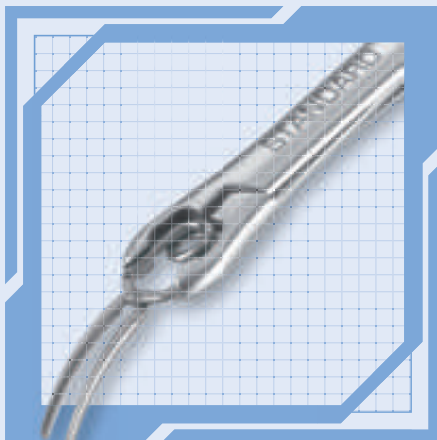
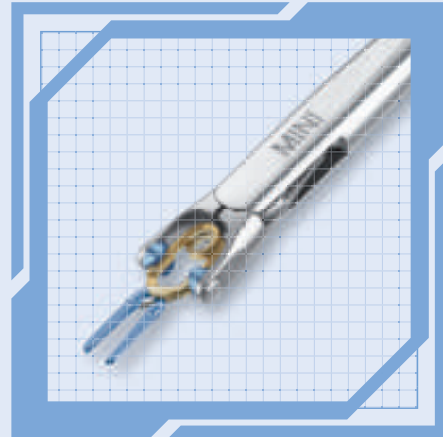
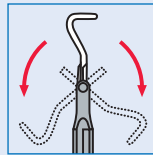

Maul mit starrer Clip-Aufnahme  
 Rigid jaw for clip application  
 Boca con acogida rígida para clips  
 Mors avec prise rigide pour clips  
 Morso da presa rigido per clip

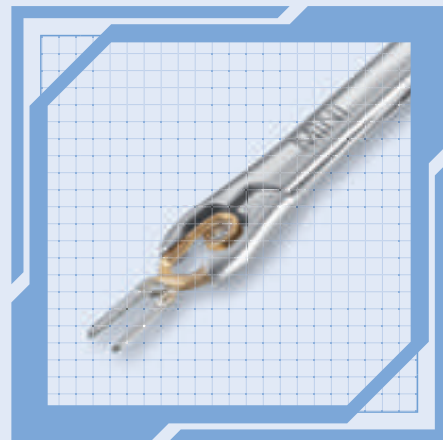
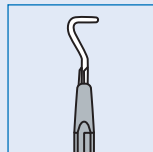

Zubehör für alle Anlegezangen mit drehbarer Clip-Aufnahme  
 Accessories for all clip applying forceps with rotatable clip application  
 Accesorios para todas las pinzas aplicadoras con acogida giratoria  
 Accessoires pour toutes les pinces à appliquer les clips avec prise pivotante  
 Accessori per tutti i posacclip con presa girevole



Einstellschlüssel  
 Adjustment wrenches  
 Llaves de ajuste  
 Clés de réglage  
 Chiave di regolazione



1:1



TITANIUM	<b>58.60.45</b>
PHYNOX	<b>58.60.46</b>



**Anlegezangen**  
**Applying Forceps**  
**Pinzas para aplicar**  
**Pinces à appliquer**  
**Pinze per applicare**

**B08**

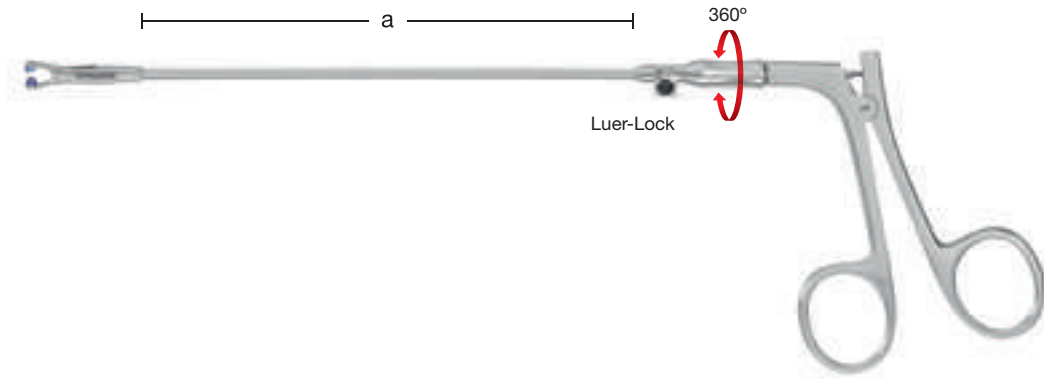

**Yasargil**

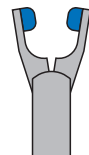
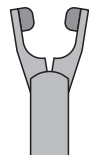
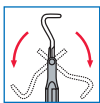
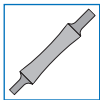

**PHYNOX**

a = 7 cm – 2¾"	<b>58.30.91</b>
a = 9 cm – 3½"	<b>58.30.92</b>
a = 11 cm – 4¾"	<b>58.30.93</b>
a = 13 cm – 5½"	<b>58.30.94</b>

**TITANIUM**

a = 7 cm – 2¾"	<b>58.31.91</b>
a = 9 cm – 3½"	<b>58.31.92</b>
a = 11 cm – 4¾"	<b>58.31.93</b>
a = 13 cm – 5½"	<b>58.31.94</b>

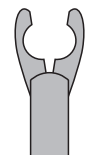
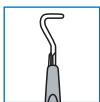

**PHYNOX**

a = 7 cm – 2¾"	<b>58.32.91</b>
a = 9 cm – 3½"	<b>58.32.92</b>
a = 11 cm – 4¾"	<b>58.32.93</b>
a = 13 cm – 5½"	<b>58.32.94</b>

**TITANIUM**

a = 7 cm – 2¾"	<b>58.33.91</b>
a = 9 cm – 3½"	<b>58.33.92</b>
a = 11 cm – 4¾"	<b>58.33.93</b>
a = 13 cm – 5½"	<b>58.33.94</b>

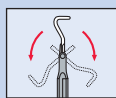

Maul mit drehbarer Clip-Aufnahme  
Rotatable jaw for clip application  
Boca con acogida giratoria para clips  
Mors avec prise pivotante pour clips  
Morso da presa girevole per clip

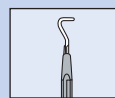

Maul mit starrer Clip-Aufnahme  
Rigid jaw for clip application  
Boca con acogida rígida para clips  
Mors avec prise rigide pour clips  
Morso da presa rigido per clip



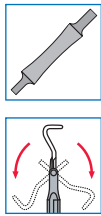
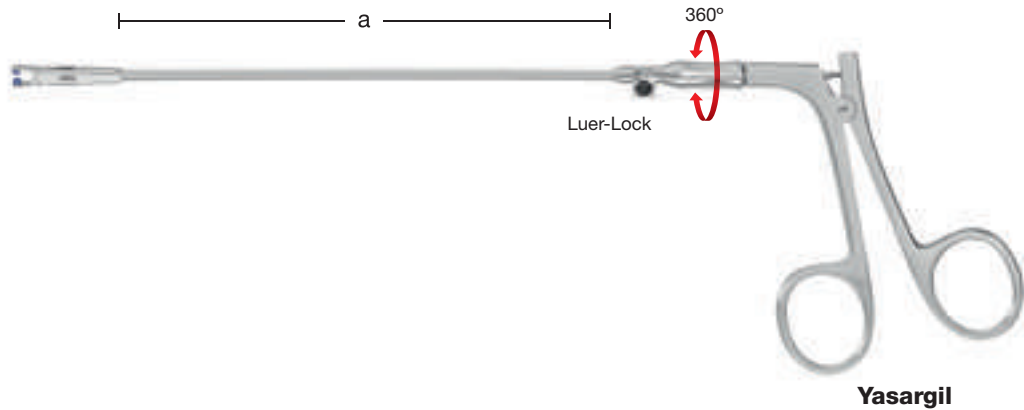

PHYNOX	
a = 7 cm – 2¾"	<b>58.34.91</b>
a = 9 cm – 3½"	<b>58.34.92</b>
a = 11 cm – 4¾"	<b>58.34.93</b>
a = 13 cm – 5½"	<b>58.34.94</b>

TITANIUM	
a = 7 cm – 2¾"	<b>58.36.91</b>
a = 9 cm – 3½"	<b>58.36.92</b>
a = 11 cm – 4¾"	<b>58.36.93</b>
a = 13 cm – 5½"	<b>58.36.94</b>

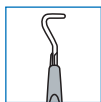

PHYNOX	
a = 7 cm – 2¾"	<b>58.37.91</b>
a = 9 cm – 3½"	<b>58.37.92</b>
a = 11 cm – 4¾"	<b>58.37.93</b>
a = 13 cm – 5½"	<b>58.37.94</b>

TITANIUM	
a = 7 cm – 2¾"	<b>58.38.91</b>
a = 9 cm – 3½"	<b>58.38.92</b>
a = 11 cm – 4¾"	<b>58.38.93</b>
a = 13 cm – 5½"	<b>58.38.94</b>

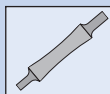

Zubehör für alle Anlegezangen mit drehbarer Clip-Aufnahme (siehe Seite 221)  
Accessories for all clip applying forceps with rotatable clip application (see page 221)  
Accesorios para todas las pinzas aplicadoras con acogida giratoria (véase página 221)  
Accessoires pour toutes les pinces à appliquer les clips avec prise pivotante (voir page 221)  
Accessori per tutti i posacclip con presa girevole (vedi pagina 221)

**B08**

**Anlegezangen (biegbar) mit Memory-Effekt**  
**Applying Forceps (flexible) with Memory Effect**  
**Pinzas para aplicar (flexible) con efecto de memoria**  
**Pinces à appliquer (flexible) avec effet de mémoire**  
**Pinze per applicare (flessibili) con effetto di memoria**

Anlegezangen mit Memory-Effekt  
 Applying forceps with memory effect  
 Pinzas para aplicar con efecto de memoria  
 Pinces à appliquer avec effet de mémoire  
 Pinze per applicare con effetto di memoria

- ▶ für die individuelle Anpassung an den OP-Situs
- ▶ beim Sterilisieren wird der Schaft in die gerade Ausgangsposition zurückgeführt
- ▶ for an individual adaptation to the operating situs
- ▶ during sterilization the shaft turns back into its initial straight position
- ▶ para una adaptación individual al sito operatorio
- ▶ durante la esterilización el vástago vuelve a su posición recta inicial
- ▶ pour une adaptation individuelle au site opératoire
- ▶ le tige reprend sa position initiale lors de la stérilisation
- ▶ per un'adattazione individuale al sito operatorio
- ▶ durante il processo di sterilizzazione l'asta viene ricondotta nella posizione iniziale

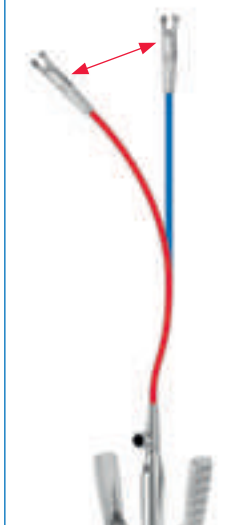
**MEMORY EFFECT**

Luer-Lock

**Yasargil**

biegbar  
malleable  
maleables  
malleables  
malleabili

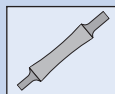

Zubehör für alle Anlegezangen mit drehbarer Clip-Aufnahme (siehe Seite 221)  
 Accessories for all clip applying forceps with rotatable clip application (see page 221)  
 Accesorios para todas las pinzas aplicadoras con acogida giratoria (véase página 221)  
 Accessoires pour toutes les pincés à appliquer les clips avec prise pivotante (voir page 221)  
 Accessori per tutti i posacclip con presa girevole (vedi pagina 221)



**Anlegezangen (biegsam) mit Memory-Effekt**  
**Applying Forceps (flexible) with Memory Effect**  
**Pinzas para aplicar (flexible) con efecto de memoria**  
**Pinces à appliquer (flexible) avec effet de mémoire**  
**Pinze per applicare (flessibili) con effetto di memoria**

**B08**

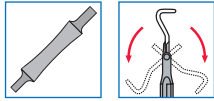

**STANDARD**

TITANIUM		PHYNOX	
a = 9 cm – 3½"	<b>58.58.01</b>	a = 9 cm – 3½"	<b>58.58.02</b>
a = 11 cm – 4¾"	<b>58.58.03</b>	a = 11 cm – 4¾"	<b>58.58.04</b>

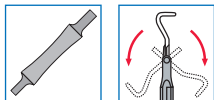

**MINI**

TITANIUM		PHYNOX	
a = 9 cm – 3½"	<b>58.60.41</b>	a = 9 cm – 3½"	<b>58.60.42</b>
a = 11 cm – 4¾"	<b>58.60.43</b>	a = 11 cm – 4¾"	<b>58.60.44</b>

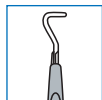

**STANDARD**

TITANIUM		PHYNOX	
a = 9 cm – 3½"	<b>58.60.31</b>	a = 9 cm – 3½"	<b>58.60.32</b>
a = 11 cm – 4¾"	<b>58.60.33</b>	a = 11 cm – 4¾"	<b>58.60.34</b>

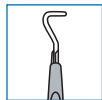

**MINI**

TITANIUM		PHYNOX	
a = 9 cm – 3½"	<b>58.60.51</b>	a = 9 cm – 3½"	<b>58.60.52</b>
a = 11 cm – 4¾"	<b>58.60.53</b>	a = 11 cm – 4¾"	<b>58.60.54</b>

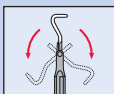

Maul mit drehbarer Clip-Aufnahme  
 Rotatable jaw for clip application  
 Boca con acogida giratoria para clips  
 Mors avec prise pivotante pour clips  
 Morso da presa girevole per clip

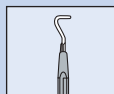

Maul mit starrer Clip-Aufnahme  
 Rigid jaw for clip application  
 Boca con acogida rígida para clips  
 Mors avec prise rigide pour clips  
 Morso da presa rigido per clip

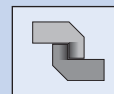

mit Sperre  
 with catch  
 con cremallera  
 avec crémaillère  
 con cremagliera



**Anlegezangen**  
**Applying Forceps**  
**Pinzas para aplicar**  
**Pinces à appliquer**  
**Pinze per applicare**

**B08**



**Yasargil**

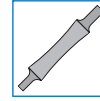
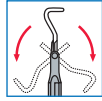

**PHYNOX**  
18 cm - 7 1/8" **58.54.36**



**Yasargil**

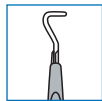

**PHYNOX**  
18 cm - 7 1/8" **58.54.96**

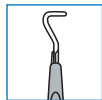

**PHYNOX**  
18 cm - 7 1/8" **58.56.96**

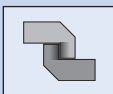

mit Sperre  
with catch  
con cremallera  
avec crémaillère  
con cremagliera

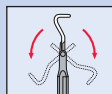

Maul mit drehbarer Clip-Aufnahme  
Rotatable jaw for clip application  
Boca con acogida giratoria para clips  
Mors avec prise pivotante pour clips  
Morso da presa girevole per clip

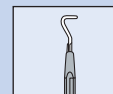

Maul mit starrer Clip-Aufnahme  
Rigid jaw for clip application  
Boca con acogida rígida para clips  
Mors avec prise rigide pour clips  
Morso da presa rigido per clip



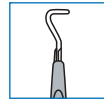

STANDARD

PHYNOX	
17 cm – 6¾"	<b>58.54.97</b>
21 cm – 8¼"	<b>58.54.98</b>
23 cm – 9"	<b>58.54.99</b>

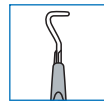

MINI

PHYNOX	
17 cm – 6¾"	<b>58.56.97</b>
21 cm – 8¼"	<b>58.56.98</b>
23 cm – 9"	<b>58.56.99</b>

Yasargil

doppelt übersetzt  
double action  
doble acción  
à double articulation  
doppia articolazione

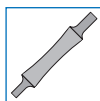

STANDARD

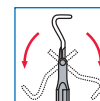

TITANIUM	
21 cm – 8¼"	<b>58.58.98</b>
23 cm – 9"	<b>58.58.99</b>

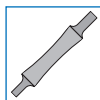

MINI

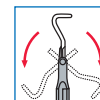

TITANIUM	
21 cm – 8¼"	<b>58.61.98</b>
23 cm – 9"	<b>58.61.99</b>



Yasargil

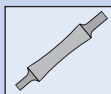

Zubehör für alle Anlegezangen mit drehbarer Clip-Aufnahme (siehe Seite 221)  
Accessories for all clip applying forceps with rotatable clip application (see page 221)  
Accesorios para todas las pinzas aplicadoras con acogida giratoria (véase página 221)  
Accessoires pour toutes les pinces à appliquer les clips avec prise pivotante (voir page 221)  
Accessori per tutti i posacclip con presa girevole (vedi pagina 221)



**Anlegezangen**  
**Applying Forceps**  
**Pinzas para aplicar**  
**Pinces à appliquer**  
**Pinze per applicare**

**B08**

doppelt übersetzt und schwenkbar  
 double action and swivelling  
 doble acción y giratorio  
 à double articulation et pivotant  
 doppia articolazione e orientabile

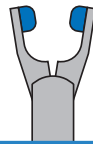
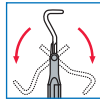
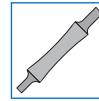
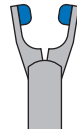
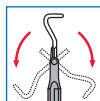
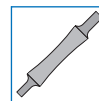
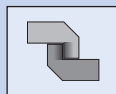
**Yasargil****STANDARD****TITANIUM**21 cm – 8¼" **58.56.91**23 cm – 9" **58.56.92****MINI****TITANIUM**21 cm – 8¼" **58.59.98**23 cm – 9" **58.59.99**

mit Sperre  
 with catch  
 con cremallera  
 avec crémaillère  
 con cremagliera

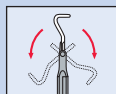

Maul mit drehbarer Clip-Aufnahme  
 Rotatable jaw for clip application  
 Boca con acogida giratoria para clips  
 Mors avec prise pivotante pour clips  
 Morso da presa girevole per clip

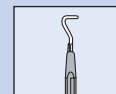

Maul mit starrer Clip-Aufnahme  
 Rigid jaw for clip application  
 Boca con acogida rígida para clips  
 Mors avec prise rigide pour clips  
 Morso da presa rigido per clip



Yasargil

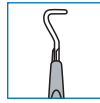

**PHYNOX**  
 21 cm – 8¼" **58.66.03**

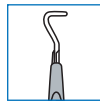

**PHYNOX**  
 21 cm – 8¼" **58.66.00**

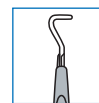

**TITANIUM**  
 21 cm – 8¼" **58.66.09**

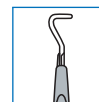

**TITANIUM**  
 21 cm – 8¼" **58.66.06**



Yasargil

doppelt übersetzt  
 double action  
 doble acción  
 à double articulation  
 doppia articolazione

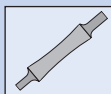



Zubehör für alle Anlegezangen mit drehbarer Clip-Aufnahme (siehe Seite 221)  
 Accessories for all clip applying forceps with rotatable clip application (see page 221)  
 Accesorios para todas las pinzas aplicadoras con acogida giratoria (véase página 221)  
 Accessoires pour toutes les pincas à appliquer les clips avec prise pivotante (voir page 221)  
 Accessori per tutti i posacclip con presa girevole (vedi pagina 221)

**B08**

**Kassette (ohne Clips und Kennzeichnungsschilder)**  
**Tray (without Clips and Identification Labels)**  
**Caja (sin clips y placas de identificación)**  
**Cassette (sans clips et étiquettes d'identification)**  
**Cassetta (senza clip e etichette d'identificazione)**

Die farbliche Kennzeichnung unterstützt die schnelle Identifikation und vereinfacht die Zuordnung untereinander.  
 The color coding scheme makes rapid identification of the parts very easy and simplifies parts matching.  
 La codificación con diferentes colores apoya la identificación y facilita la asignación entre sí.  
 Le marquage couleur permet une identification rapide et simplifie la recherche des pièces correspondantes.  
 Il codice colore facilita la rapida identificazione e agevola l'assegnazione reciproca.

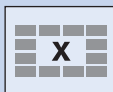

 52,8 x 25,4 x 4,0 cm  **58.60.01**

**STANDARD****MINI**

Anzahl der Fächer  
 Number of compartments  
 Número de compartimentos  
 Nombre de compartiments  
 Numero dei scompartimenti



Kunststoff (autoklavierbar bis 134 °C bei 3 bar)  
 Plastic (autoclavable up to 134 °C at 3 bar)  
 Plástico (autoclavable hasta 134 °C bajo presión de 3 bar)  
 Plastique (autoclavable à 134 °C sous pression de 3 bars)  
 Plastica (autoclavabile fino a 134 °C sotto pressione di 3 bar)

**Kennzeichnungsschilder**  
**Identification Labels**  
**Placas de identificación**  
**Etiquettes d'identification**  
**Etichette d'identificazione**

**B08**

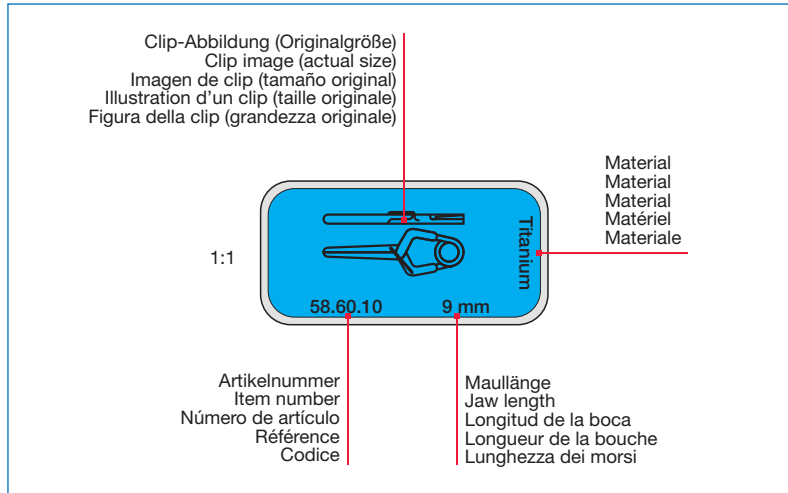

Die Beschriftung der Kennzeichnungsschilder erfolgt separat auf Bestellung!

Identification labels have to be ordered separately!

La inscripción de las placas de identificación se realiza de manera separada por pedido!

Les inscriptions sur les étiquettes sont déterminées séparément, sur commande!

La scritta sulla targhetta identificativa viene eseguita separatamente su ordinazione!

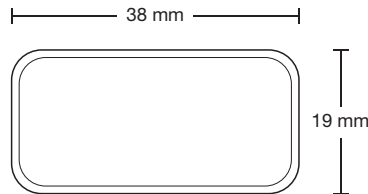

**PERMANENT**  
**58.60.02**

**TEMPORARY**  
**58.60.03**



**PERMANENT**  
**58.60.04**

**TEMPORARY**  
**58.60.03**



Kunststoff (autoklavierbar bis 134 °C bei 3 bar)  
 Plastic (autoclavable up to 134 °C at 3 bar)  
 Plástico (autoclavable hasta 134 °C bajo presión de 3 bar)  
 Plastique (autoclavable à 134 °C sous pression de 3 bars)  
 Plastica (autoclavabile fino a 134 °C sotto pressione di 3 bar)



# B08

**Kassetten (ohne Clips und Kennzeichnungsschilder)**  
**Trays (without Clips and Identification Labels)**  
**Cajas (sin clips y placas de identificación)**  
**Cassettes (sans clips et étiquettes d'identification)**  
**Cassette (senza clip e etichette d'identificazione)**





 66    55,6 × 25,0 × 3,3 cm        **58.60.00**

**STANDARD**  
**MINI**

stapelbar  
stackable  
apilable  
empilable  
impilabile



 28    25,0 × 26,0 × 3,3 cm        **58.60.05**

**STANDARD**  
**MINI**

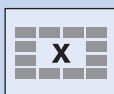

Anzahl der Fächer  
Number of compartments  
Número de compartimentos  
Nombre de compartiments  
Numero dei scompartimenti



Kunststoff (autoklavierbar bis 134 °C bei 3 bar)  
Plastic (autoclavable up to 134 °C at 3 bar)  
Plástico (autoclavable hasta 134 °C bajo presión de 3 bar)  
Plastique (autoclavable à 134 °C sous pression de 3 bars)  
Plastica (autoclavabile fino a 134 °C sotto pressione di 3 bar)

Das 1,5 mm Neuro-Fixationssystem wurde zur Fixierung von kranialen Knochen entwickelt. Das System beinhaltet die Produktlinie "BASIC" und die in Zusammenarbeit mit Dr. David L. Masel, El Paso, Texas (USA) entwickelte Produktlinie "LOW PROFILE".

The 1.5 mm Neuro-fixation system was specially developed for fixation of cranial bone. The system includes the "BASIC" product line and the "LOW PROFILE" product line developed in collaboration with Dr. David L. Masel, El Paso, Texas (USA).

El sistema para neuro-fijación de 1,5 mm se desarrolló especialmente para la fijación de huesos del cráneo. El sistema incluye la línea de productos "BASIC" y la línea de productos "LOW PROFILE" desarrollada con la cooperación del Dr. David L. Masel, El Paso, Texas (USA).

Le système de fixation Neuro 1,5 mm a été spécialement développé pour fixer la os crânién. Ce système comprend la ligne de produits "BASIC" et la ligne de produits "LOW PROFILE" développée en collaboration avec le Dr. David L. Masel, El Paso, Texas (USA).

Il sistema di neuro-fissaggio da 1,5 mm è stato appositamente sviluppato per il fissaggio dell'osso cranico. Il sistema include la linea di prodotti "BASIC" e la linea di prodotti "LOW PROFILE" sviluppata in collaborazione con il Dr. David L. Masel, El Paso, Texas (USA).

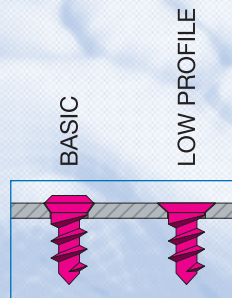

Die sehr flachen Köpfe der "Low Profile"-Schrauben lassen sich komplett in die Platten versenken.

The "Low Profile" screw heads are very flat and can be completely sunk into the plates.

Las cabezas extremadamente planas de los tornillos "Low Profile" pueden embutirse completamente en las placas.

Les têtes de vis très plates "Low Profile" s'enfoncent complètement dans les plaques.

Le teste estremamente piatte delle viti "Low Profile" sono completamente inseribili a scomparsa nelle placche.



**Neuro-Fixationssystem**  
**Neuro-Fixation System**  
**Sistema para neuro-fijación**  
**Système de neuro-fixation**  
**Sistema di neuro-fissaggio**

**B09**

**BASIC**  
**1.5 mm**

Titan-Platten  
Titanium plates  
Placas de titanio  
Plaques en titane  
Placche in titanio

<p>"I-Form" P 2</p>	<p>9 mm</p> <p>②</p> <p><b>68.87.02</b></p> <p>0,6 mm</p>	<p>12 mm</p> <p>②</p> <p><b>68.87.07</b></p> <p>0,6 mm</p>	<p>15 mm</p> <p>②</p> <p><b>68.87.03</b></p> <p>0,6 mm</p>
-------------------------	---	--	--

<p>"I-Form" P 5</p>	<p>4,5 mm</p> <p>④</p> <p><b>68.87.14</b></p> <p>0,6 mm</p>	<p>7,5 mm</p> <p>④</p> <p><b>68.87.34</b></p> <p>0,6 mm</p>	<p>9 mm</p> <p>④</p> <p><b>68.87.44</b></p> <p>0,6 mm</p>	<p>⑥</p> <p><b>68.87.46</b></p> <p>0,6 mm</p>
-------------------------	---	---	---	---

<p>"Y-Form" P 5</p>	<p>8 mm</p> <p>④</p> <p><b>68.87.70</b></p> <p>0,6 mm</p>	<p>12 mm</p> <p>④</p> <p><b>68.87.72</b></p> <p>0,6 mm</p>
-------------------------	---	--

<p>"2Y-Form" P 5</p>	<p>⑥</p> <p><b>68.87.74</b></p> <p>0,6 mm</p>	<p>⑦</p> <p><b>68.87.75</b></p> <p>0,6 mm</p>	<p>"I-Form" P 2</p>	<p>⑩⑥</p> <p><b>68.87.59</b></p> <p>0,6 mm</p>
--------------------------	---	---	-------------------------	--



**X** Anzahl der Löcher  
Number of holes  
Número de orificios  
Nombre de trous  
Numero dei fori

Plattenstärke  
Thickness of plates  
Grosor de las placas  
Epaisseur des plaques  
Spessore delle placche

**P** Verpackungseinheit "X" Stück  
Packing unit "X" pieces  
Paquete de "X" unidades  
Emballage de "X" pièces  
Confezione da "X" pezzi



# BASIC 1.5 mm

**Neuro-Fixationssystem**  
**Neuro-Fixation System**  
**Sistema para neuro-fijación**  
**Système de neuro-fixation**  
**Sistema di neuro-fissaggio**

# B09

Titan-Platten  
Titanium plates  
Placas de titanio  
Plaques en titane  
Placche in titanio

	 (4) <b>68.87.77</b> 0,6 mm			
"X-Form" 				
	 (4) <b>68.86.11</b> 0,6 mm	 (4) <b>68.86.12</b> 0,6 mm	 (6) <b>68.86.13</b> 0,6 mm	 (8) <b>68.86.14</b> 0,6 mm
"Multi Grid" 				

Bohrlochabdeckplatten  
Burr hole plates  
Placas para tapar los orificios perforados  
Plaques pour trous de forage  
Placche di copertura per fori

	Ø 13 mm  (5) <b>68.86.60</b> 0,4 mm	Ø 18,5 mm  (5) <b>68.86.61</b> 0,4 mm	Ø 22 mm  (6) <b>68.86.62</b> 0,4 mm	Ø 29 mm  (5) <b>68.86.63</b> 0,4 mm
"Burr Hole" 				

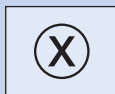

Anzahl der Löcher  
Number of holes  
Número de orificios  
Nombre de trous  
Numero dei fori

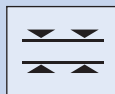

Plattenstärke  
Thickness of plates  
Grosor de las placas  
Epaisseur des plaques  
Spessore delle placche

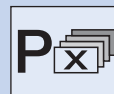

Verpackungseinheit "X" Stück  
Packing unit "X" pieces  
Paquete de "X" unidades  
Emballage de "X" pièces  
Confezione da "X" pezzi

**B09**

**Neuro-Fixationssystem**  
**Neuro-Fixation System**  
**Sistema para neuro-fijación**  
**Système de neuro-fixation**  
**Sistema di neuro-fissaggio**

**BASIC**  
**1.5 mm**

Titan-Platten  
 Titanium plates  
 Placas de titanio  
 Plaques en titane  
 Placche in titanio

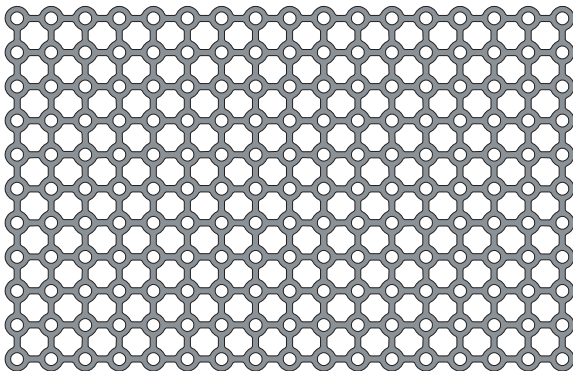

"Multi Grid Mesh"



74 x 50 mm

**68.86.88**

"Multi Grid Mesh"

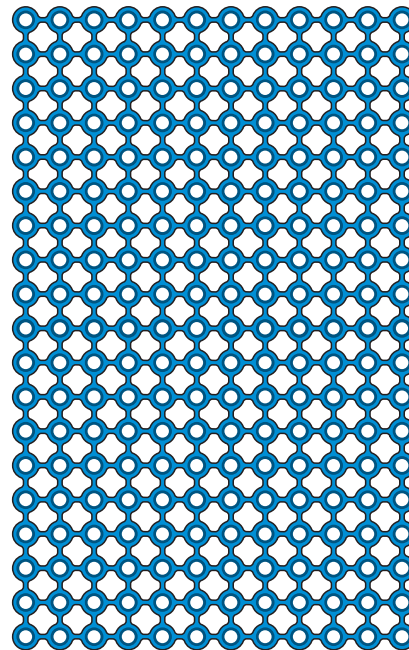

53 x 85 mm

**68.86.89**

53 x 85 mm

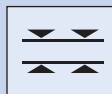
**68.86.90**

Plattenstärke  
 Thickness of plates  
 Grosor de las placas  
 Epaisseur des plaques  
 Spessore delle placche

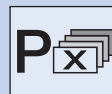

Verpackungseinheit "X" Stück  
 Packing unit "X" pieces  
 Paquete de "X" unidades  
 Emballage de "X" pièces  
 Confezione da "X" pezzi

**BASIC**  
**1.5 mm**

**Neuro-Fixationssystem**  
**Neuro-Fixation System**  
**Sistema para neuro-fijación**  
**Système de neuro-fixation**  
**Sistema di neuro-fissaggio**

**B09**

Titan-Platten  
Titanium plates  
Placas de titanio  
Plaques en titane  
Placche in titanio

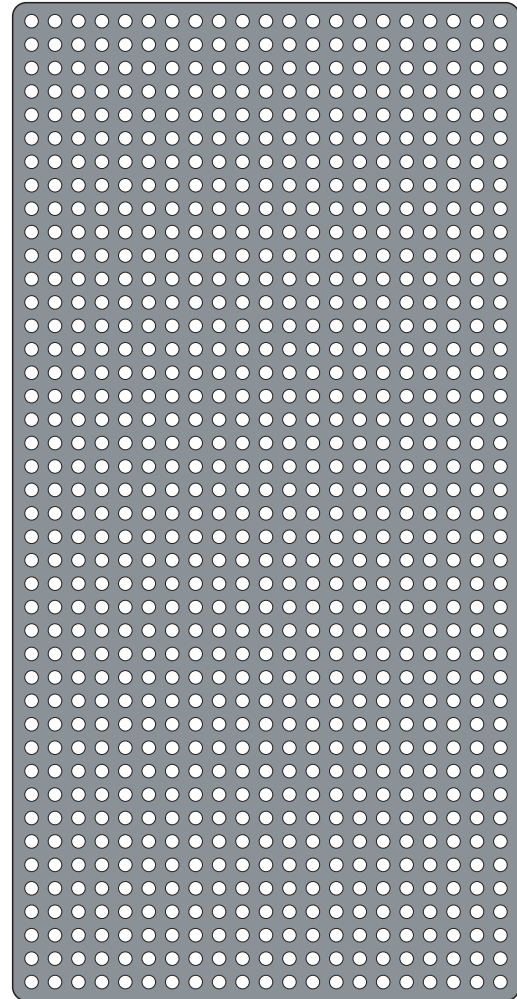
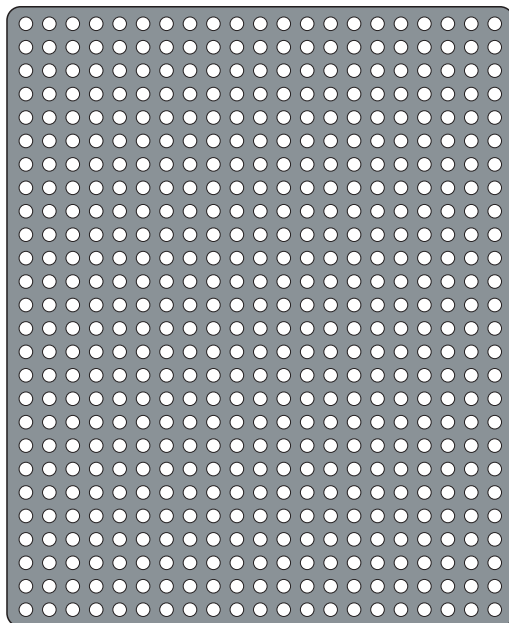

"Multi Grid Mesh"	82 × 67 mm	82 × 67 mm
	<b>68.86.91</b>	<b>68.86.92</b>

"Multi Grid Mesh"	132 × 67 mm	132 × 67 mm
	<b>68.86.93</b>	<b>68.86.94</b>

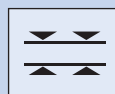

Plattenstärke  
Thickness of plates  
Grosor de las placas  
Epaisseur des plaques  
Spessore delle placche

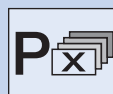

Verpackungseinheit "X" Stück  
Packing unit "X" pieces  
Paquete de "X" unidades  
Emballage de "X" pièces  
Confezione da "X" pezzi



**Neuro-Fixationssystem**  
**Neuro-Fixation System**  
**Sistema para neuro-fijación**  
**Système de neuro-fixation**  
**Sistema di neuro-fissaggio**

**B09**

**BASIC**  
**1.5 mm**

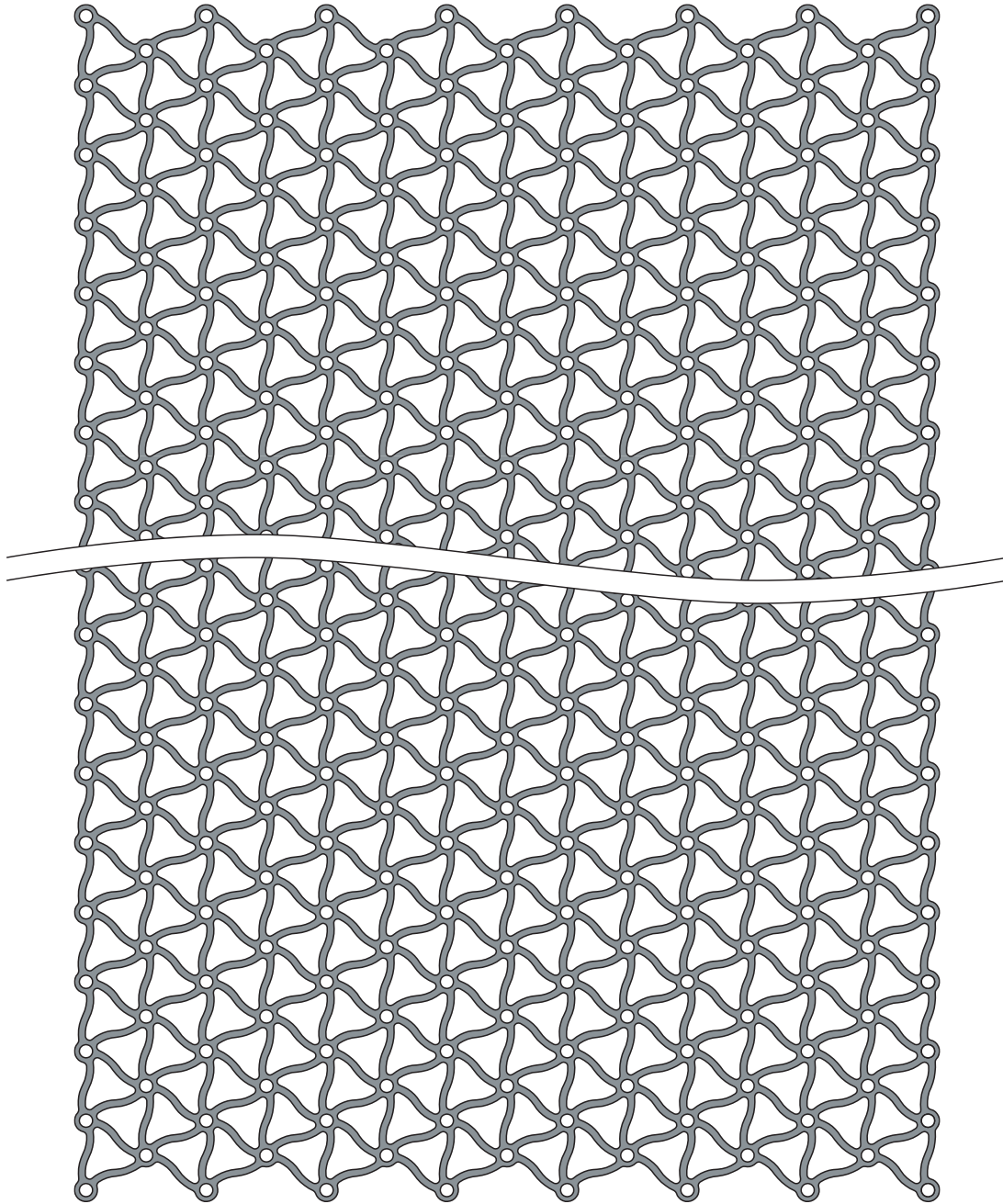

"Mesh" 	125 x 203 mm	125 x 203 mm
	<b>68.87.00</b>	<b>68.87.01</b>
	$\frac{0.4 \text{ mm}}{\text{---}}$	$\frac{0.6 \text{ mm}}{\text{---}}$

Plattenstärke  
 Thickness of plates  
 Grosor de las placas  
 Epaisseur des plaques  
 Spessore delle placche

Verpackungseinheit "X" Stück  
 Packing unit "X" pieces  
 Paquete de "X" unidades  
 Emballage de "X" pièces  
 Confezione da "X" pezzi

**BASIC**  
1.5 mm

**Neuro-Fixationssystem**  
**Neuro-Fixation System**  
**Sistema para neuro-fijación**  
**Système de neuro-fixation**  
**Sistema di neuro-fissaggio**

**B09**

Titan-Platten  
Titanium plates  
Placas de titanio  
Plaques en titane  
Placche in titanio

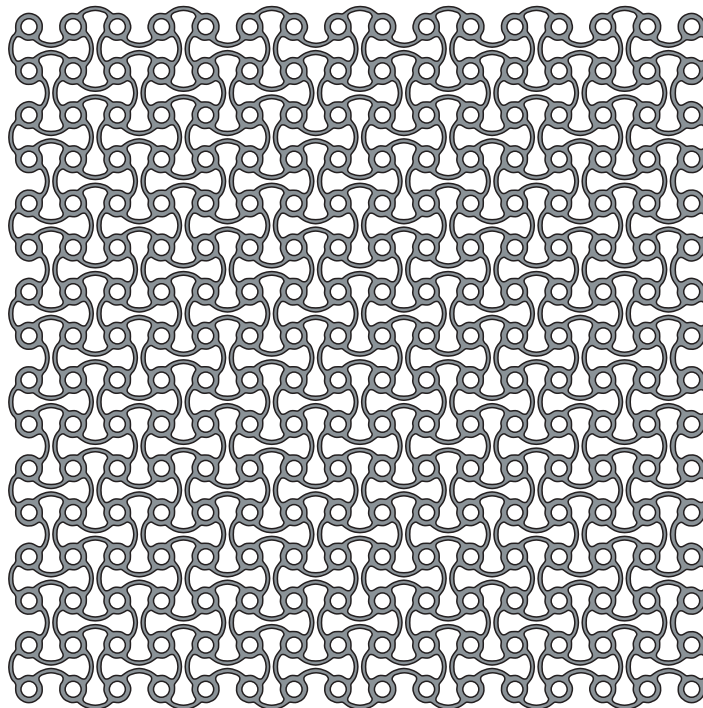

"Mesh" 	90 × 90 mm <b>68.87.27</b>  0,4 mm	90 × 90 mm <b>68.87.28</b>  0,6 mm
------------	---	---

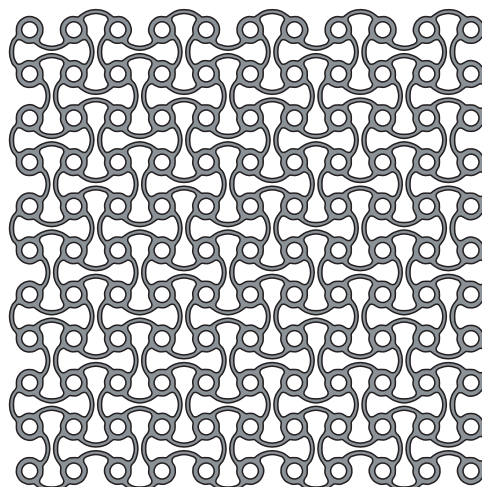

"Mesh" 	61 × 61 mm <b>68.87.29</b>  0,4 mm	61 × 61 mm <b>68.87.30</b>  0,6 mm
------------	---	---

Plattenstärke  
 Thickness of plates  
 Grosor de las placas  
 Epaisseur des plaques  
 Spessore delle placche

Verpackungseinheit "X" Stück  
 Packing unit "X" pieces  
 Paquete de "X" unidades  
 Emballage de "X" pièces  
 Confezione da "X" pezzi

**B09**

**Neuro-Fixationssystem**  
**Neuro-Fixation System**  
**Sistema para neuro-fijación**  
**Système de neuro-fixation**  
**Sistema di neuro-fissaggio**

**BASIC**  
**1.5 mm**

Titan-Schrauben  
 Titanium screws  
 Tornillos de titanio  
 Vis en titane  
 Viti in titanio



10 Schrauben im Magazin (nicht steril)  
 10 screws in storage tray (non-sterile)  
 10 tornillos en cartucho (no estéril)  
 10 vis en cartouche (non stériles)  
 10 viti nella cartuccia (non sterile)



Self-drilling

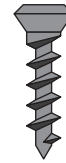

Self-tapping



Emergency screw

a	Ø 1,5 mm	Ø 1,5 mm	Ø 1,9 mm
3,5 mm	<b>68.83.73A</b>	<b>68.83.53A</b>	
4,0 mm	<b>68.83.74A</b>	<b>68.83.54A</b>	<b>68.83.84A</b>
5,0 mm	<b>68.83.75A</b>	<b>68.83.55A</b>	
6,0 mm			<b>68.83.86A</b>

a	Ø 1,5 mm	Ø 1,5 mm	Ø 1,9 mm
3,5 mm		<b>68.83.03A</b>	
4,0 mm		<b>68.83.04A</b>	<b>68.83.34A</b>
5,0 mm		<b>68.83.05A</b>	
6,0 mm			<b>68.83.36A</b>

a	Ø 1,5 mm	Ø 1,5 mm	Ø 1,9 mm
3,5 mm	<b>68.85.83A</b>	<b>68.85.43A</b>	
4,0 mm	<b>68.85.84A</b>	<b>68.85.44A</b>	<b>68.85.64A</b>
5,0 mm	<b>68.85.85A</b>	<b>68.85.45A</b>	
6,0 mm			<b>68.85.66A</b>

a	Ø 1,5 mm	Ø 1,5 mm	Ø 1,9 mm
3,5 mm	<b>68.85.73A</b>	<b>68.85.03A</b>	
4,0 mm	<b>68.85.74A</b>	<b>68.85.04A</b>	<b>68.85.24A</b>
5,0 mm	<b>68.85.75A</b>	<b>68.85.05A</b>	
6,0 mm			<b>68.85.26A</b>

**“EASY GRIP”**

Schraubenkopf mit konischem Innenvierkant  
 Screw head with tapered inside square  
 Tornillo de cabeza con cuadrado interior cónico  
 Tête de vis avec quatre-pans intérieur conique  
 Testa della vite con quadrangolo interno conico

**“MASTER GRIP”**

Schraubenkopf mit einem Schlitz  
 Screw head with slot  
 Tornillo de cabeza ranurada  
 Tête de vis avec fente  
 Testa della vite ad intaglio

**“POWER GRIP”**

Schraubenkopf mit kreuzförmigem Schlitz  
 Screw head with cross slot  
 Tornillo de cabeza ranurada en cruz  
 Tête de vis avec fente cruciforme  
 Testa della vite a croce

**“STAR GRIP”**

Schraubenkopf mit sternförmigem Schlitz  
 Screw head with star slot  
 Tornillo de cabeza ranurada en estrella  
 Tête de vis avec fente forme d'étoile  
 Testa della vite a stella



SELF-DRILLING

Bei harter Kortikalis oder Fixation kleiner Knochenfragmente wird ein Vorbohren empfohlen.

In case of hard cortical bone substance or fixation of small bone fragments we recommend pre-drilling.

En caso de una cortical muy dura o de la fijación de fragmentos pequeños recomendamos la perforación previa.

Pour le cas où la corticale serait trop dure ou pour la fixation de petits fragments osseux, nous recommandons un préforage.

In presenza di una corticale molto dura oppure per la fissazione di piccoli frammenti consigliamo di perforare prima dell'inserimento della vite.



Selbstbohrend  
**Self-drilling**  
 Auto perforante  
 Auto perforante  
 Auto perforante



Selbstschneidend  
**Self-tapping**  
 Autoroscante  
 Autotaraudeuse  
 Autofilettante



Notfallschraube (selbstschneidend)  
**Emergency screw (self-tapping)**  
 Tornillo de emergencia (autoroscante)  
 Vis d'urgence (autotaraudeuse)  
 Vite d'emergenza (autofilettante)

# BASIC 1.5 mm

**Neuro-Fixationssystem**  
**Neuro-Fixation System**  
**Sistema para neuro-fijación**  
**Système de neuro-fixation**  
**Sistema di neuro-fissaggio**

# B09

Schraubendrehergriffe  
Screwdriver handles  
Mangos para atornillador  
Manches de tournevis  
Manici per cacciavite

Schraubendreherklingen  
Screwdriver blades  
Hojas para atornillador  
Lames de tournevis  
Lame per cacciavite



10 cm - 4" **75.23.50**



10 cm - 4" **75.23.52**



10 cm - 4" **75.23.78A**

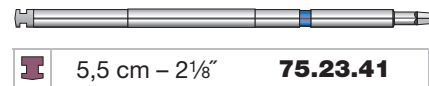

**I** 5,5 cm - 2 1/8" **75.23.41** 1:1

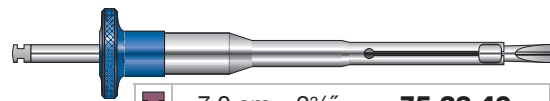

**I** 7,0 cm - 2 3/4" **75.23.49** 1:1

mit Greifvorrichtung  
with gripping device  
con garra  
avec préhenseur  
con dispositivo da presa

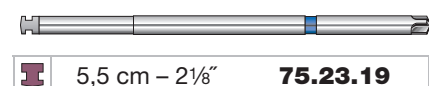

**I** 5,5 cm - 2 1/8" **75.23.19** 1:1

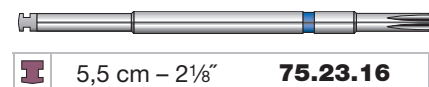

**I** 5,5 cm - 2 1/8" **75.23.16** 1:1

Spiralbohrer  
Twist drills  
Brocas espirales  
Forets hélicoïdaux  
Perforatori elicoidali

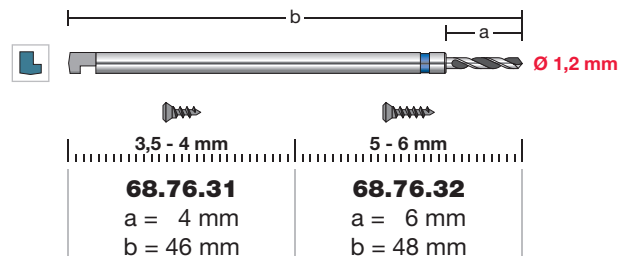

**B09**

**Neuro-Fixationssystem**  
**Neuro-Fixation System**  
**Sistema para neuro-fijación**  
**Système de neuro-fixation**  
**Sistema di neuro-fissaggio**

**LOW PROFILE**  
**1.5 mm**

Die 0,4 mm "Low Profile"-Platten ermöglichen eine der Knochenkontur angepaßte Fixierung in kranialen Regionen mit geringer Weichteildecke.

The 0.4 mm "Low Profile" plates allow fixation matched to the bone contour in cranial regions with low soft tissue coverage.

Las placas "Low Profile" de 0,4 mm permiten la fijación adaptada al contorno óseo en las regiones craneales con una capa delgada de partes blandas.

Les plaques "Low Profile" de 0,4 mm permettent une fixation adaptée aux contours osseux dans la zone crânienne, avec une couverture minimale des tissus mous.

Le placche "Low Profile" da 0,4 mm consentono un fissaggio che si adatta al profilo dell'osso delle regioni craniche con ridotta copertura del tessuto molle.



Titan-Platten  
 Titanium plates  
 Placas de titanio  
 Plaques en titane  
 Placche in titanio

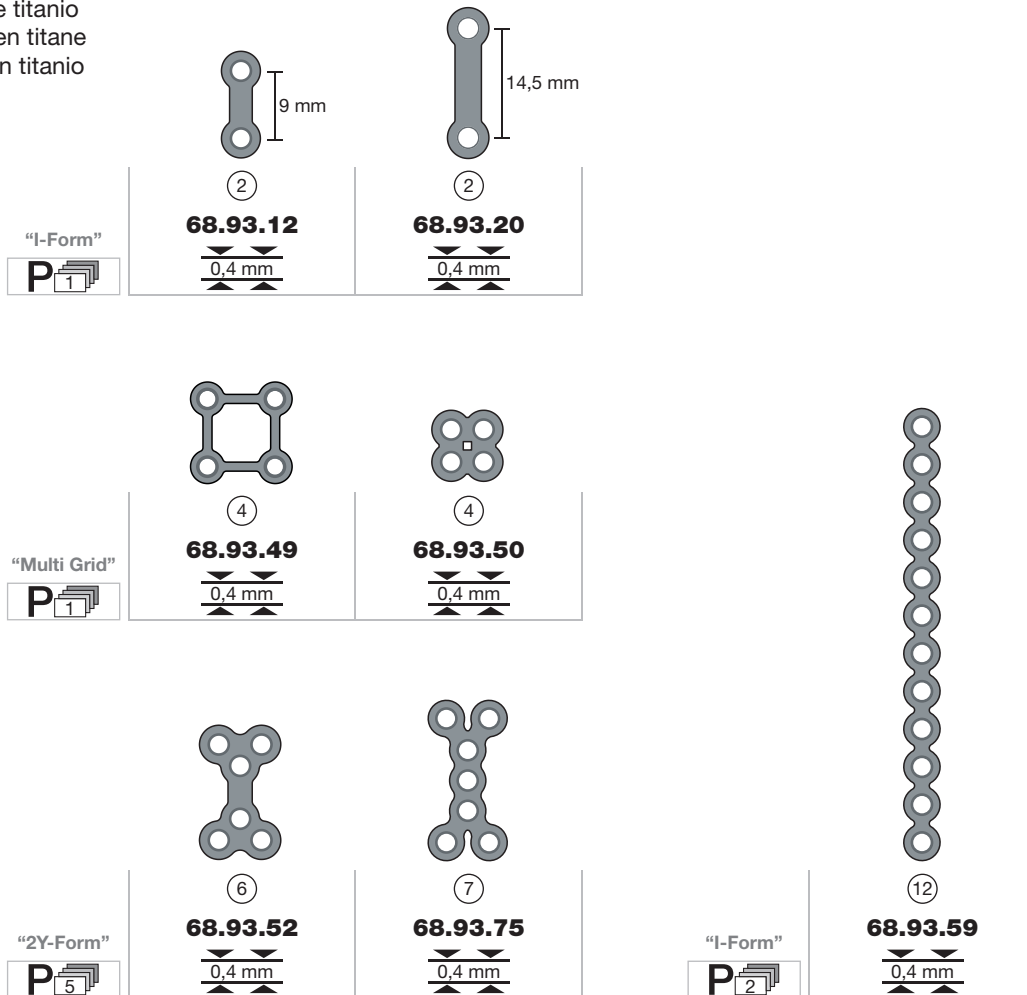

Anzahl der Löcher  
 Number of holes  
 Número de orificios  
 Nombre de trous  
 Numero dei fori

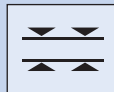

Plattenstärke  
 Thickness of plates  
 Grosor de las placas  
 Epaisseur des plaques  
 Spessore delle placche

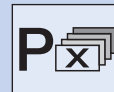

Verpackungseinheit "X" Stück  
 Packing unit "X" pieces  
 Paquete de "X" unidades  
 Emballage de "X" pièces  
 Confezione da "X" pezzi





**LOW PROFILE  
1.5 mm**

**Neuro-Fixationssystem  
Neuro-Fixation System  
Sistema para neuro-fijación  
Système de neuro-fixation  
Sistema di neuro-fissaggio**

**B09**



- ▶ Ermöglicht die sichere Liquorpassage eines Katheters
- ▶ Keine scharfen Kanten
- ▶ Kein Einschneiden der Platte notwendig
- ▶ Keine Schwächung der Platte
  
- ▶ Allows a safe smooth passage of an underlying catheter
- ▶ No sharp edges
- ▶ No cutting of the plate necessary
- ▶ No degradation of the plate
  
- ▶ Facilita el seguro pasaje del catéter a través del licar
- ▶ Sin bordes cortantes
- ▶ No existe la necesidad de entallar las placas
- ▶ No debilitar las placas
  
- ▶ Permet un meilleur passage du cathéter dans le liquide cérébro-spinal
- ▶ Pas d'arrête coupante
- ▶ Prédécoupage de la plaque non nécessaire
- ▶ Plaque non fragilisée
  
- ▶ Permette la sicura circolazione del liquido cerebrospinale
- ▶ Senza bordi taglienti
- ▶ Non è necessario incidere la placca
- ▶ Nessun indebolimento della placca

Bohrlochabdeckplatten  
Burr hole plates  
Placas para tapar los orificios perforados  
Plaques pour trous de forage  
Placche di copertura per fori

	Ø 13 mm	Ø 18,5 mm
	(5)	(5)
	<b>68.93.54</b>	<b>68.93.53</b>
	<b>Masel</b>	<b>Masel</b>
"Shunt" 		

	Ø 13 mm	Ø 18,5 mm	Ø 22 mm
	(5)	(5)	(6)
	<b>68.93.60</b>	<b>68.93.51</b>	<b>68.93.62</b>
"Burr Hole" 			

**B09**

**Neuro-Fixationssystem**  
**Neuro-Fixation System**  
**Sistema para neuro-fijación**  
**Système de neuro-fixation**  
**Sistema di neuro-fissaggio**

**LOW PROFILE**  
**1.5 mm**

Die sehr flachen Köpfe der "Low Profile"-Schrauben lassen sich komplett in die Platten versenken.

The "Low Profile" screw heads are very flat and can be completely sunk into the plates.

Las cabezas extremadamente planas de los tornillos "Low Profile" pueden embutirse completamente en las placas.

Les têtes de vis très plates "Low Profile" s'enfoncent complètement dans les plaques.

Le teste estremamente piatte delle viti "Low Profile" sono completamente inseribili a scomparsa nelle placche.



Titan-Schrauben  
 Titanium screws  
 Tornillos de titanio  
 Vis en titane  
 Viti in titanio



10 Schrauben im Magazin (nicht steril)  
 10 screws in storage tray (non-sterile)  
 10 tornillos en cartucho (no estéril)  
 10 vis en cartouche (non stériles)  
 10 viti nella cartuccia (non sterile)

**"EASY GRIP"**

Schraubenkopf mit konischem Innenvierkant  
 Screw head with tapered inside square  
 Tornillo de cabeza con cuadrado interior cónico  
 Tête de vis avec quatre-pans intérieur conique  
 Testa della vite con quadrangolo interno conico

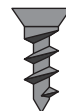

Self-tapping



Emergency screw

a	Ø 1,5 mm	Ø 1,9 mm
4,0 mm	<b>68.93.00A</b>	<b>68.93.05A</b>

**"POWER GRIP"**

Schraubenkopf mit kreuzförmigem Schlitz  
 Screw head with cross slot  
 Tornillo de cabeza ranurada en cruz  
 Tête de vis avec fente cruciforme  
 Testa della vite a croce



Self-drilling



Emergency screw

a	Ø 1,5 mm	Ø 1,9 mm
3,5 mm	<b>68.93.23A</b>	
4,0 mm	<b>68.93.24A</b>	<b>68.93.34A</b>



SELF-DRILLING

Bei harter Kortikalis oder Fixation kleiner Knochenfragmente wird ein Vorbohren empfohlen.

In case of hard cortical bone substance or fixation of small bone fragments we recommend pre-drilling.

En caso de una cortical muy dura o de la fijación de fragmentos pequeños recomendamos la perforación previa.

Pour le cas où la corticale serait trop dure ou pour la fixation de petits fragments osseux, nous recommandons un préforage.

In presenza di una corticale molto dura oppure per la fissazione di piccoli frammenti consigliamo di perforare prima dell'inserimento della vite.



Selbstbohrend  
**Self-drilling**  
 Auto perforante  
 Auto perforante  
 Auto perforante



Selbstschneidend  
**Self-tapping**  
 Autoroscante  
 Autotaraudeuse  
 Autofilettante



Notfallschraube (selbstschneidend)  
**Emergency screw (self-tapping)**  
 Tornillo de emergencia (autoroscante)  
 Vis d'urgence (autotaraudeuse)  
 Vite d'emergenza (autofilettante)

# LOW PROFILE 1.5 mm

**Neuro-Fixationssystem**  
**Neuro-Fixation System**  
**Sistema para neuro-fijación**  
**Système de neuro-fixation**  
**Sistema di neuro-fissaggio**

# B09

Schraubendrehergriffe  
Screwdriver handles  
Mangos para atornillador  
Manches de tournevis  
Manici per cacciavite

Schraubendreherklingen  
Screwdriver blades  
Hojas para atornillador  
Lames de tournevis  
Lame per cacciavite



10 cm - 4" **75.23.50**



10 cm - 4" **75.23.52**



10 cm - 4" **75.23.78A**



**I** 5,5 cm - 2 1/8" **75.23.41** 1:1



**I** 5,5 cm - 2 1/8" **75.23.19** 1:1



Spiralbohrer  
Twist drill  
Broca espiral  
Foret hélicoïdal  
Perforatore elicoidale

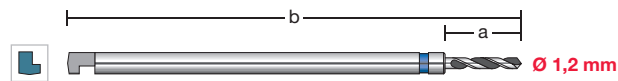

3,5 - 4 mm  
**68.76.31**  
a = 4 mm  
b = 46 mm



Verpackungseinheit "X" Stück  
Packing unit "X" pieces  
Paquete de "X" unidades  
Emballage de "X" pièces  
Confezione da "X" pezzi

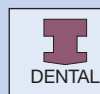

Ansatz  
Shank end  
Talón  
Embout  
Attacco



Ansatz  
Shank end  
Talón  
Embout  
Attacco

**B09**

**Neuro-Fixationssystem**  
**Neuro-Fixation System**  
**Sistema para neuro-fijación**  
**Système de neuro-fixation**  
**Sistema di neuro-fissaggio**

Draht- und Mesh-Plattenschere  
 Wire and Mesh plate cutting scissors  
 Tijera para cortar alambre y placas Mesh  
 Ciseaux coupe-fil et coupe-plaques Mesh  
 Forbice per fili d'acciaio e placche Mesh



12 cm - 4¾"  
**14.26.72**

"HM"



12 cm - 4¾"  
**14.23.62**

max. Ø 0,3 mm

Harte Drähte  
 Hard wires  
 Alambres duros  
 Fils durs  
 Fili duri

max. Ø 0,8 mm

Weiche Drähte  
 Soft wires  
 Alambres blandos  
 Fils mous  
 Fili dolci

Universal "HM"

Draht- und Plattenschneidezangen  
 Wire and plate cutting pliers  
 Alicates para cortar alambre y placas  
 Pincés coupe-fils et coupe-plaques  
 Pinze per tagliare fili e placche



13 cm - 5½"  
**14.30.13**

"HM"

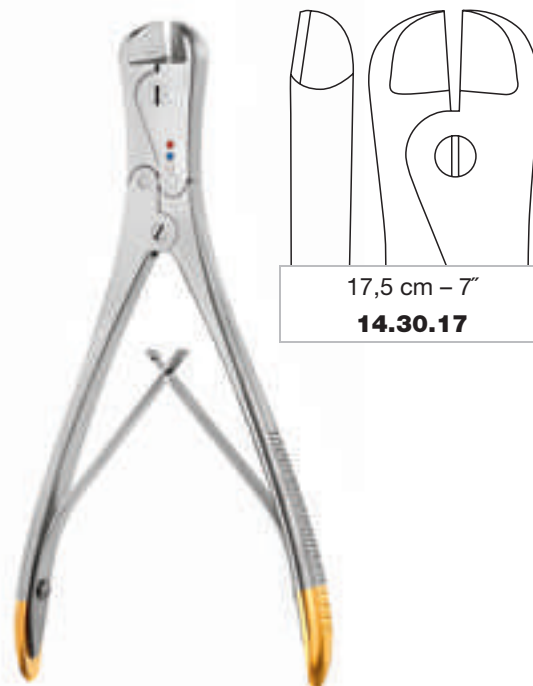

17,5 cm - 7"  
**14.30.17**

"HM"

"HM"

Hartmetall  
 Tungsten carbide  
 Carburo de tungsteno  
 Carbure de tungstène  
 Carburo di tungsteno



seitwärts gewinkelt  
 angled to side  
 acodadas hacia et lado  
 coudés latéralement  
 angolata lateralment



Eine Schneide gezahnt  
 One blade serrated  
 Una hoja dentada  
 Une lame dentelée  
 Una lama dentellata

Plattenbiegeezangen  
 Plate bending pliers  
 Pinzas para doblar placas  
 Pincas pour plier les plaques  
 Pinze piegaplacche



13 cm – 5 1/8"  
**68.76.41**



13 cm – 5 1/8"  
**68.76.52**

Schraubenhaltepinzette  
 Screw holding forceps  
 Pinza de agarre para tornillos  
 Pince pour tenir les vis  
 Pinza da presa per viti

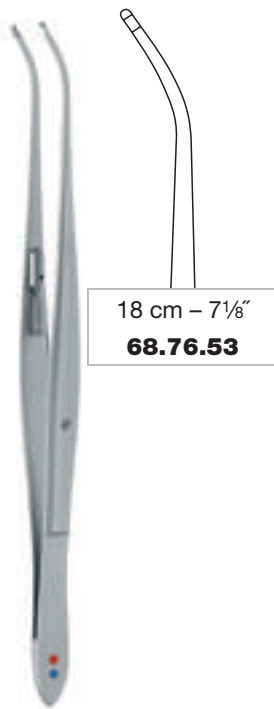

18 cm – 7 1/8"  
**68.76.53**

Plattenhaltepinzetten  
 Plate holding forceps  
 Pinzas de agarre para placas  
 Pincas pour tenir les plaques  
 Pinze da presa per placche



13 cm – 5 1/8"  
**68.76.06**

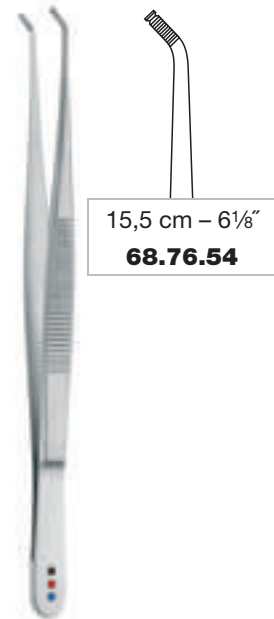

15,5 cm – 6 1/8"  
**68.76.54**

**B09**

**Neuro-Fixationssystem**  
**Neuro-Fixation System**  
**Sistema para neuro-fijación**  
**Système de neuro-fixation**  
**Sistema di neuro-fissaggio**

Bohrlochtiefenlehre  
 Depth gauge for drill-holes  
 Instrumento para medir la profundidad  
 Instrument pour mesurer la profondeur  
 Strumento per misurare la profondità



20 cm – 8" **68.76.56**

Adaptionsinstrument  
 Applying instrument  
 Instrumento de adaptación  
 Instrument d'adaptation  
 Strumento per adattamento



14 cm – 5½" **68.76.44**

Kassette (ohne Implantate, Schrauben und Werkzeuge)  
 Tray (without implants, screws and tools)  
 Caja (sin implantes, tornillos y sus respectivos instrumentos)  
 Cassette (sans implants, vis et outils)  
 Cassetta (senza impianti, viti e strumentario)



230 x 235 x 55 mm **69.02.40**

Empfohlene Bestückung  
 Recommended set  
 Recomendación de equipamiento  
 Recommendation d'équipement  
 Raccomandazione per la dotazione

<b>14.26.72</b>	Wire and Mesh plate cutting scissors	1x
<b>68.76.31</b>	Twist drill (4/46 mm)	2x
<b>68.76.32</b>	Twist drill (6/48 mm)	2x
<b>68.76.54</b>	Plate holding forceps	1x
<b>75.23.19</b>	Screwdriver blades	2x
<b>75.23.50</b>	Screwdriver handles	2x
Instrumente, optional Instruments, optional Instrumentos, opcional Instruments, optionnel Strumenti, opzionale		
<b>75.23.16</b>	Screwdriver blades	2x
<b>75.23.41</b>	Screwdriver blades	2x
<b>75.23.49</b>	Screwdriver blades	2x
<b>75.23.52</b>	Screwdriver handles	2x
<b>75.23.78A</b>	Screwdriver handles	2x

Mit Universal-Fächern zur individuellen Bestückung  
 With universal compartments for individual equipment  
 Con compartimentos universales para una composición individual  
 Avec compartiments universels pour équipement individuel  
 Con scomparti universali per la dotazione individuale

Sterilgut-Container aus Aluminium  
 Aluminium container for sterilization  
 Contenedor de aluminio para la esterilización  
 Container en aluminium pour la stérilisation  
 Contenitore in alluminio per sterilizzazione

silber eloxiert, mit Papierfilter  
 silver anodized, with paper filter  
 anodizado en plata, con filtro de papel  
 couleur argent anodisé, avec filtre de papier  
 color argento anodizzato, con filtri di cartace



290 × 290 × 135 mm

**49.50.13**

Siebkorb  
 Wire basket  
 Cestilla  
 Panier  
 Cestello



240 × 255 × 50 mm

**49.97.02**



Unser komplettes MEDICONTAINER-Programm finden Sie in unserem Sonderprospekt.  
 For our complete MEDICONTAINER program please ask for our special brochure.  
 Nuestro programa completo de MEDICONTAINER se encuentra en nuestro folleto especial.  
 Vous trouverez notre programme complet des MEDICONTAINER dans notre prospectus spécial.  
 Il nostro programma completo di MEDICONTAINER si trova nel catalogo speciale.



Deckel gelocht  
 Lid perforated  
 Tapa perforada  
 Couvercle perforé  
 Coperchio forato





**B09**

**Sets zur Fixierung des kranialen Knochendeckels**  
**Sets for Fixation of Cranial Bone Flap**  
**Juegos para la fijación de la calota craneal**  
**Jeux pour la fixation du couvercle osseux crânien**  
**Set per il fissaggio della calotta cranica**

**1.5 MICRO NEURO FLAP SET****STERILE**

Sterile Verpackung  
 Sterile packaging  
 Embalaje estéril  
 Emballage stérile  
 Imballaggio sterile

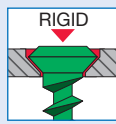
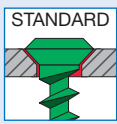

		68.85.98S	68.85.99S
Sets bestehend aus: Sets consisting of: Juegos compuestos por: Jeux composés de: Set composti da:	<b>“POWER GRIP”</b> <b>Ø 1,5 mm</b> Titan-Schrauben mit kreuzförmigem Schlitz (selbstbohrend) Titanium screws with cross slot (self-drilling) Tornillos de titanio ranurada en cruz (autoperforante) Vis en titane avec fente cruciforme (autoperforante) Viti in titanio con intaglio a croce (autoperforante)	 a = 4 mm	 a = 4 mm
	<b>“RIGID”</b> <b>0,6 mm</b> Titan-Platten zur Fixierung des kranialen Knochendeckels Titanium plates for fixation of cranial bone flap Placas de titanio para la fijación de la calota craneal Plaques en titane pour la fixation du couvercle osseux crânien Placche in titanio per il fissaggio della calotta cranica	 a = 12 mm	 a = 10 mm

**“RIGID”**

Die vergrößerte Senkbohrung lässt den Schraubenkopf tiefer in die Platte einsinken.  
 The enlarged lower borehole permits a deeper sinking of the screwhead into the plate.  
 El hundimiento mayor permite que el tornillo profundiza en la placa.  
 Le plus gros forage permet à la tête de vis d'être plus profondément insérée dans la plaque.  
 L'incavo ingrandito permette alla testa della vite di infossarsi più profondamente.

Zubehör (nicht im Set enthalten)  
 Accessory (not included in set)  
 Accesorios (no forman parte del set)  
 Accessoires (not inclus dans le set)  
 Accessori (non incluso nel set)

Schraubendrehergriffe  
 Screwdriver handles  
 Mangos para atornillador  
 Manches de tournevis  
 Manici per cacciavite

**75.23.50****75.23.52****75.23.78A**

Spiralbohrer  
 Twist drill  
 Broca espiral  
 Foret hélicoïdal  
 Perforatore elicoidale

STRYKER  **68.76.31**

Schraubendreherklinge  
 Screwdriver blade  
 Hoja para atornillador  
 Lame de tournevis  
 Lama per cacciavite

DENTAL  **75.23.19**



Bei harter Kortikalis oder Fixation kleiner Knochenfragmente wird ein Vorbohren empfohlen.  
 In case of hard cortical bone substance or fixation of small bone fragments we recommend pre-drilling.  
 En caso de una cortical muy dura o de la fijación de fragmentos pequeños recomendamos la perforación previa.  
 Pour le cas où la corticale serait trop dure ou pour la fixation de petits fragments osseux, nous recommandons un préforage.  
 In presenza di una corticale molto dura oppure per la fissazione di piccoli frammenti consigliamo di perforare prima dell'inserimento della vite.

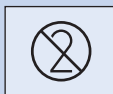

Einmalprodukt  
 Single use product  
 Producto para un solo uso  
 Produit à usage unique  
 Prodotto monouso

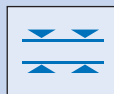

Plattenstärke  
 Thickness of plates  
 Grosor de las placas  
 Epaisseur des plaques  
 Spessore delle placche

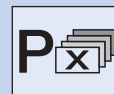

Verpackungseinheit "X" Stück  
 Packing unit "X" pieces  
 Paquete de "X" unidades  
 Emballage de "X" pièces  
 Confezione da "X" pezzi





**Instrumente für die Hypophysektomie**  
**Instruments for Hypophysectomy**  
**Instrumentos para la hipofisectomía**  
**Instrumentos pour l'hypophysectomie**  
**Strumenti per ipofisectomia**

**B10**

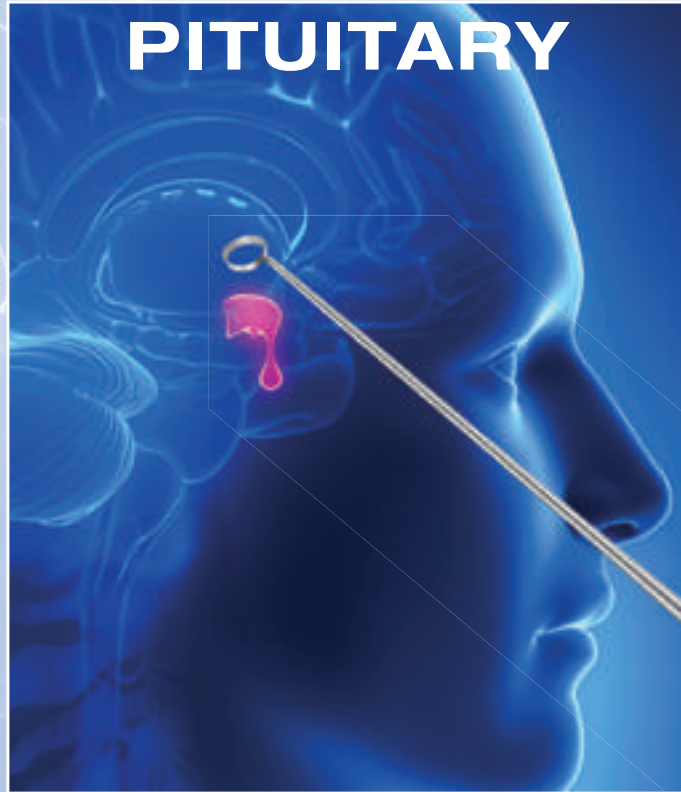



**Instrumente für die Hypophysektomie**  
**Instruments for Hypophysectomy**  
**Instrumentos para la hipofisectomía**  
**Instrumentos pour l'hypophysectomie**  
**Strumenti per ipofisectomia**

# B10

Küretten  
 Curettes  
 Curetas  
 Curettes  
 Curette

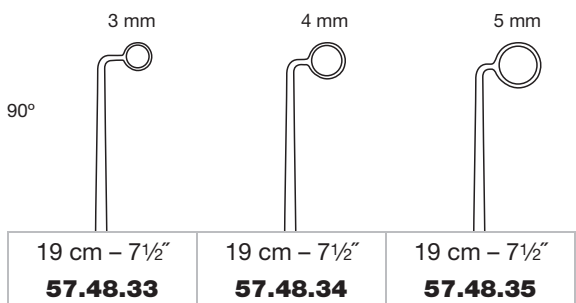
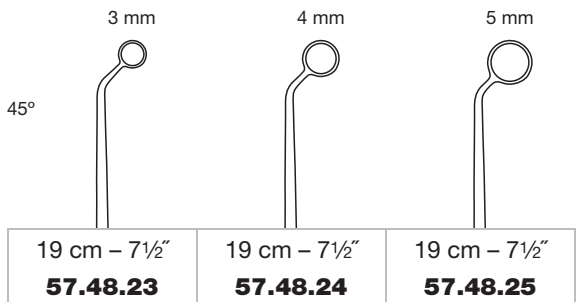
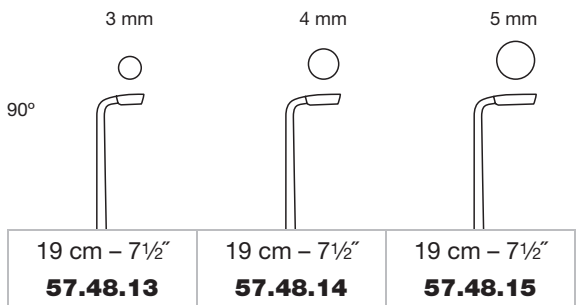
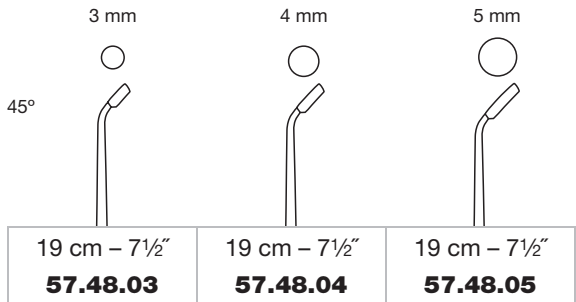

**Instrumente für die Hypophysektomie**  
**Instruments for Hypophysectomy**  
**Instrumentos para la hipofisectomía**  
**Instrumenti per l'ipofisectomia**

**B10**

Küretten  
 Currettes  
 Curetas  
 Curettes  
 Curette

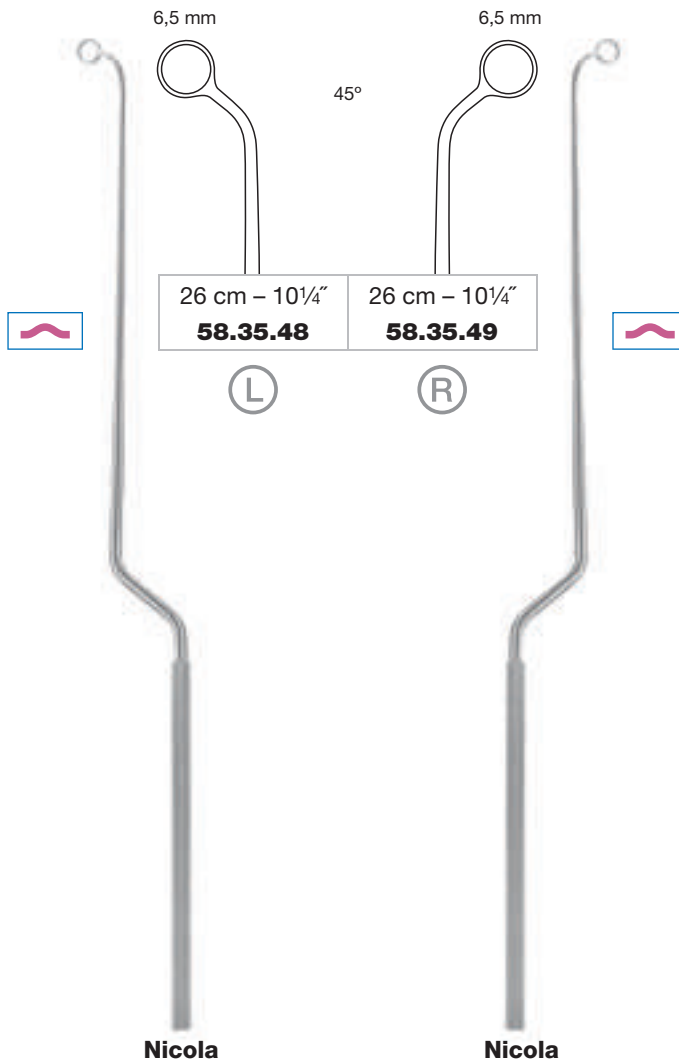
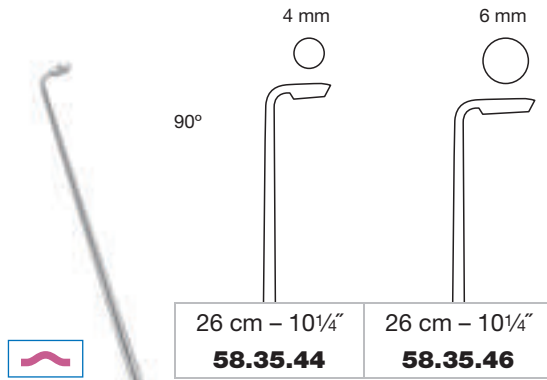

 biegsam  
 malleable  
 maleables  
 malleables  
 malleabili

 links schneidend  
 left side cutting  
 cortante hacia izquierda  
 coupante à gauche  
 tagliente a sinistra

 rechts schneidend  
 right side cutting  
 cortante hacia derecha  
 coupante à droite  
 tagliente a destra



**Instrumente für die Hypophysektomie**  
**Instruments for Hypophysectomy**  
**Instrumentos para la hipofisectomía**  
**Instrumentos pour l'hypophysectomie**  
**Strumenti per ipofisectomia**

# B10

Küretten  
 Currettes  
 Curetas  
 Curettes  
 Curette

Löffel  
 Curette  
 Cucharilla  
 Curette  
 Cucchiaino

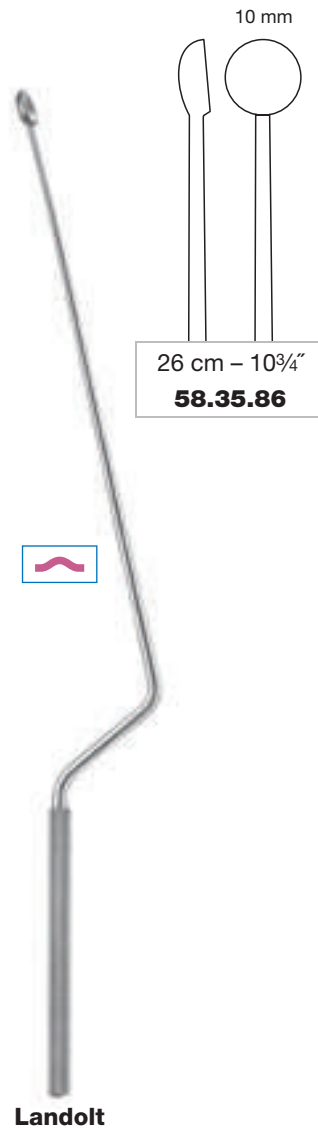
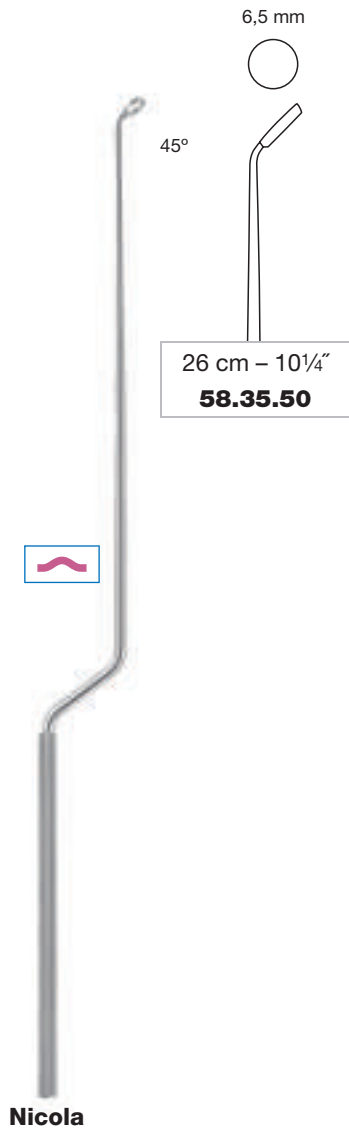

biegbar  
 malleable  
 maleables  
 malléables  
 malleabili

**Instrumente für die Hypophysektomie**  
**Instruments for Hypophysectomy**  
**Instrumentos para la hipofisectomía**  
**Instrumentos pour l'hypophysectomie**  
**Strumenti per ipofisectomia**

**B10**

Häkchen  
 Hooks  
 Ganchitos  
 Crochets  
 Uncini

Dissektor  
 Dissector  
 Disector  
 Dissecteur  
 Dissettore



stumpf  
 blunt  
 romo  
 mousse  
 smussa



biegbar  
 malleable  
 maleables  
 malléables  
 malleabili



**Instrumente für die Hypophysektomie**  
**Instruments for Hypophysectomy**  
**Instrumentos para la hipofisectomía**  
**Instrumentos pour l'hypophysectomie**  
**Strumenti per ipofisectomia**

# B10

Enukleatoren  
 Eucleators  
 Enucleadores  
 Enucleateurs  
 Enucleatori

Raspatorium  
 Raspatory  
 Legras  
 Rugine  
 Periostotomo

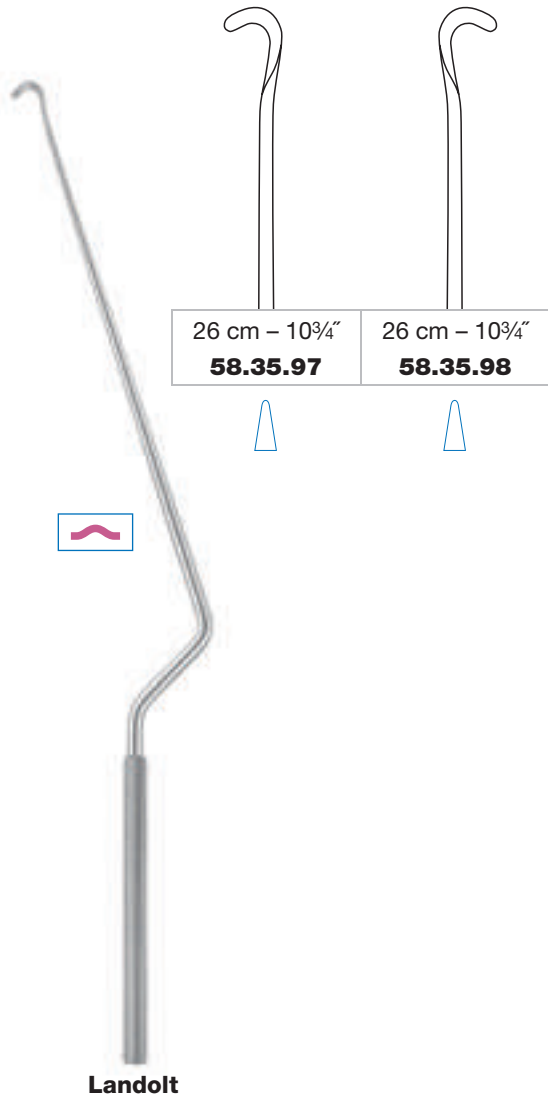

**Landolt**



**Landolt-Reulen**



stumpf  
 blunt  
 romo  
 mousse  
 smussa



biegbar  
 malleable  
 malleables  
 malleables  
 malleabili

**Instrumente für die Hypophysektomie**  
**Instruments for Hypophysectomy**  
**Instrumentos para la hipofisectomía**  
**Instrumentos pour l'hypophysectomie**  
**Strumenti per ipofisectomia**

**B10**

Meißel für die Lamina  
 Lamina chisel  
 Cincel para lámina  
 Ciseau burin pour les lames  
 Scalpello per lamina



Tumorfasszange  
 Tumor grasping forceps  
 Pinza para agarrar tumores  
 Pince à saisir pour tumeurs  
 Pinza per afferrare tumori

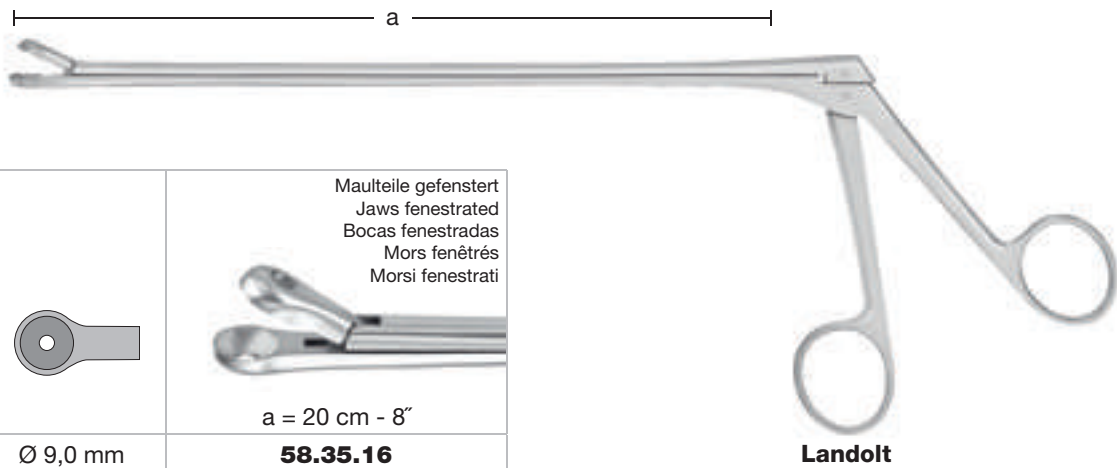

	<p>Maulteile gefenstert                  Jaws fenestrated                  Bocas fenestradas                  Mors fenêtrés                  Morsi fenestrati</p>
<p>Ø 9,0 mm</p>	<p>a = 20 cm - 8"  <b>58.35.16</b></p>

**B10**

**Instrumente für die Hypophysektomie**  
**Instruments for Hypophysectomy**  
**Instrumentos para la hipofisectomía**  
**Instrumentes pour l'hypophysectomie**  
**Strumenti per ipofisectomia**

Löffelzangen  
 Forceps cup jaws  
 Pinzas con boca de cucharilla  
 Pincers mors cuillère  
 Pinze con morso a cucchiaio

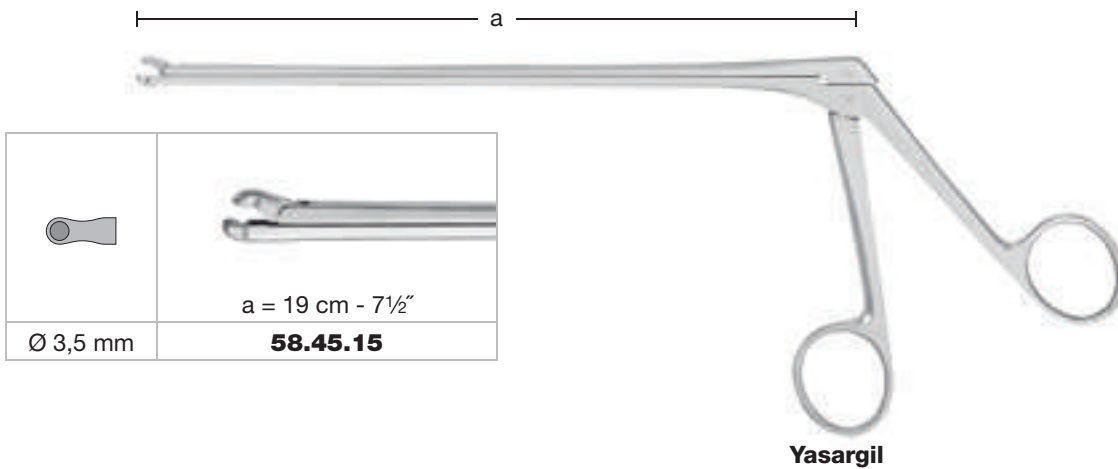
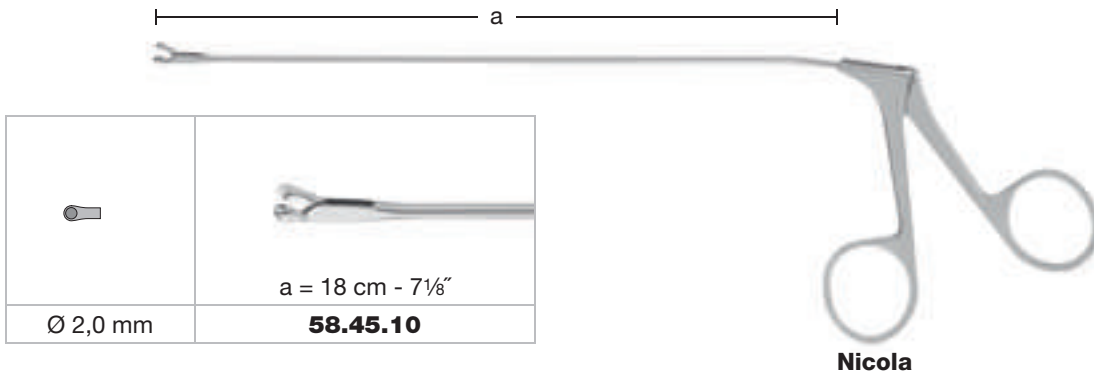
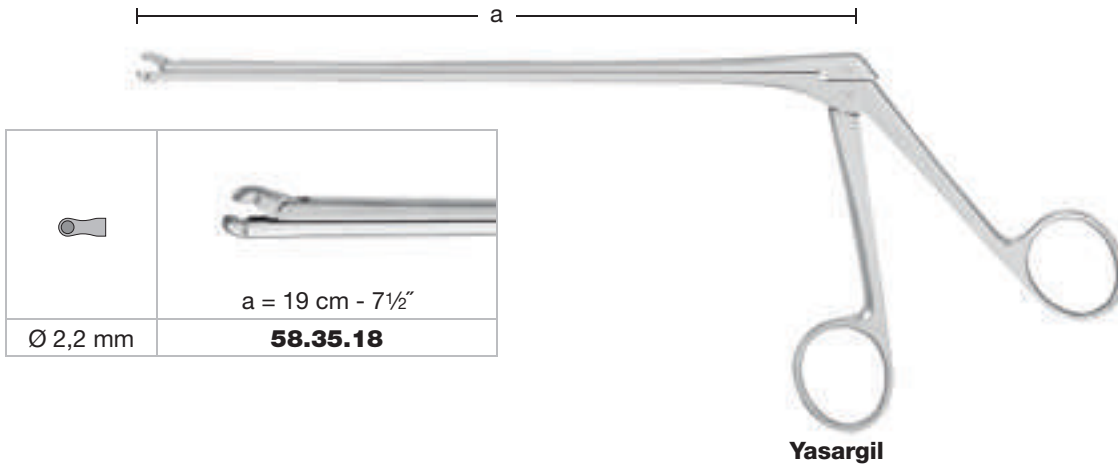



Mikro-Löffelzangen  
 Micro forceps cup jaws  
 Micro pinzas con boca de cucharilla  
 Micro pinces mors cuillère  
 Micro pinze con morso a cucchiaio

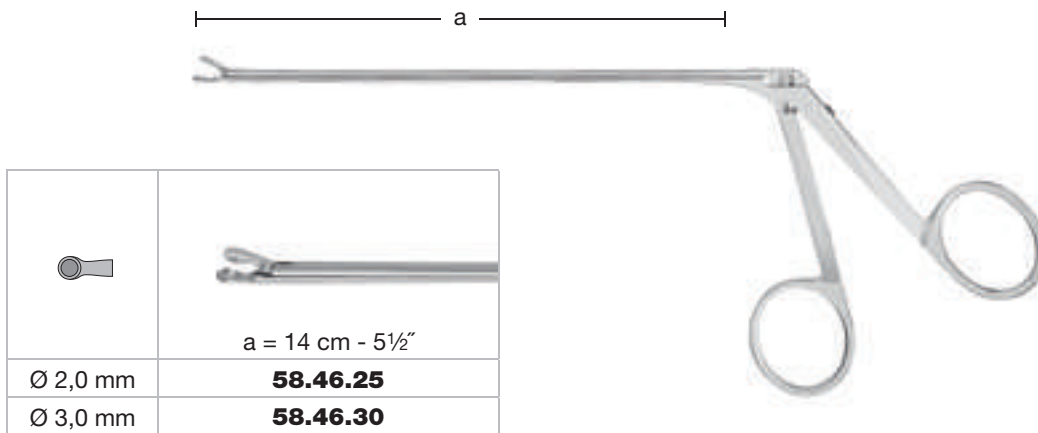
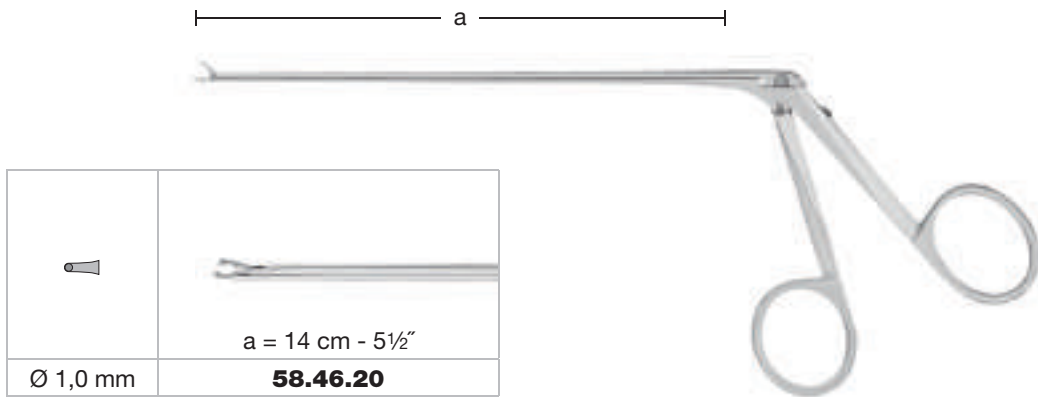



**Instrumente für die Hypophysektomie**  
**Instruments for Hypophysectomy**  
**Instrumentos para la hipofisectomía**  
**Instrumentos pour l'hypophysectomie**  
**Strumenti per ipofisectomia**

**B10**

Fasszange  
 Grasping forceps  
 Pinza para agarrar  
 Pince à saisir  
 Pinza per afferrare

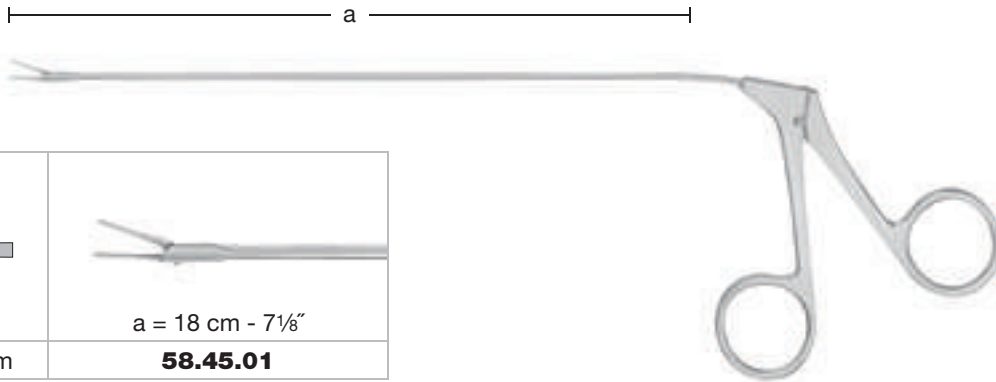

1,0 mm	a = 18 cm - 7 1/8"
	<b>58.45.01</b>

**Yasargil**

Mikro-Schere  
 Micro scissors  
 Micro tijera  
 Micro ciseaux  
 Micro forbice

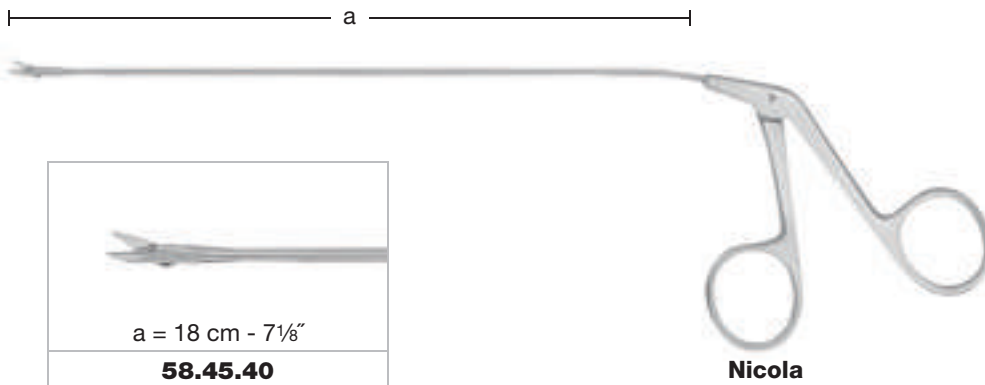

	a = 18 cm - 7 1/8"
	<b>58.45.40</b>

**Nicola**



**Instrumente für die transssphenoidale Hypophysektomie**  
**Instruments for Transssphenoidal Hypophysectomy**  
**Instrumentos para la hipofisectomía transesfenoidal**  
**Instrumentos pour l'hypophysectomie transsphénoïdale**  
**Strumenti per ipofisectomia transfenoidale**

**B10**

Dissektoren  
 Dissectors  
 Disectores  
 Dissecteurs  
 Dissettori

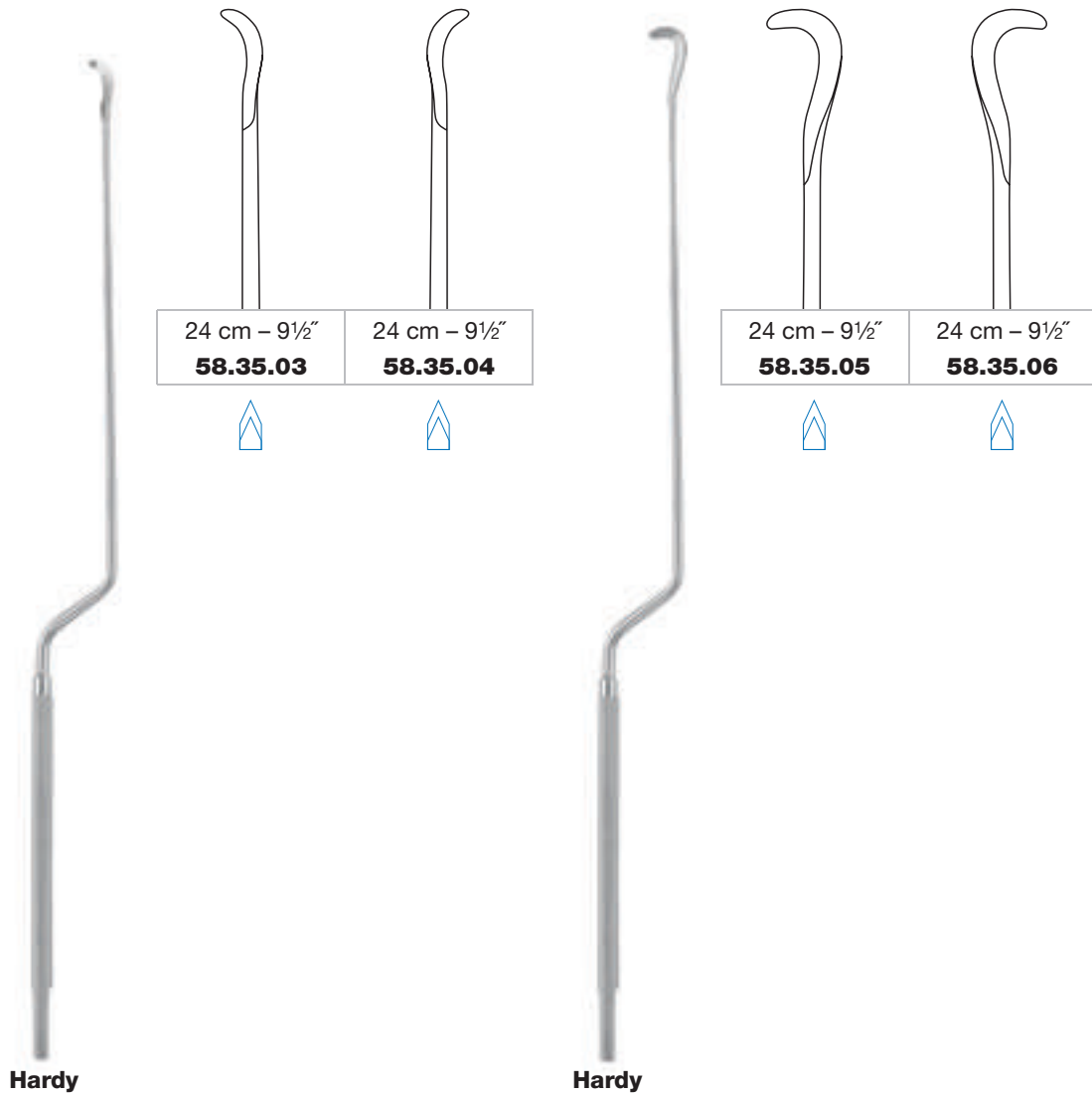

scharf  
 sharp  
 cortante  
 tranchant  
 acuta



**Instrumente für die transspheoidale Hypophysektomie**  
**Instruments for Transsphenoidal Hypophysectomy**  
**Instrumentos para la hipofisectomía transesfenoidal**  
**Instrumentos pour l'hypophysectomie transsphénoïdale**  
**Strumenti per ipofisectomia transfenoidale**

**B10**

Enukleatoren  
 Eucleators  
 Eucleadores  
 Enucléateurs  
 Eucleatori

Implantationsgabel  
 Implant fork  
 Horquilla para implantar  
 Fourchette pour implants  
 Forchetta per trapianto



**Hardy**



24 cm – 9½"  
**58.35.07**



24 cm – 9½"  
**58.35.08**



**Hardy**



24 cm – 9½"  
**58.35.19**



stumpf  
 blunt  
 romo  
 mousse  
 smussa

**Instrumente für die transssphenoidale Hypophysektomie**  
**Instruments for Transssphenoidal Hypophysectomy**  
**Instrumentos para la hipofisectomía transesfenoidal**  
**Instrumentos pour l'hypophysectomie transsphénoïdale**  
**Strumenti per ipofisectomia transfenoidale**

**B10**

Spekula  
 Specula  
 Espéculos  
 Spéculums  
 Specoli

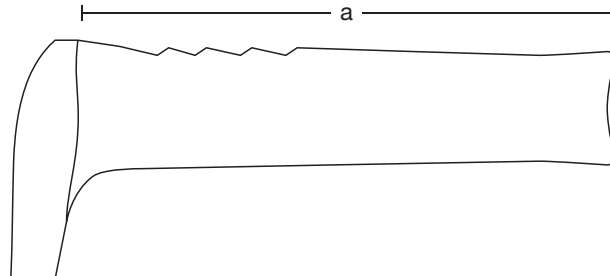

a = 70 mm	<b>58.35.70</b>
a = 90 mm	<b>58.35.90</b>
a = 110 mm	<b>58.35.91</b>

**Cushing-Landolt**

Spreizzange für Spekula  
 Spreading forceps for specula  
 Pinza dilatador para espéculos  
 Pince écartante pour spéculums  
 Pinza divaricatrice per specoli



21 cm – 8¼"	<b>58.35.99</b>
-------------	-----------------

**Landolt**

**B10**

**Instrumente für die transsphenoïdale Hypophysektomie**  
**Instruments for Transsphenoidal Hypophysectomy**  
**Instrumentos para la hipofisectomía transesfenoidal**  
**Instrumentos pour l'hypophysectomie transsphénoïdale**  
**Strumenti per ipofisectomia transfenoidale**

Spekula  
 Specula  
 Espéculos  
 Spéculums  
 Specoli

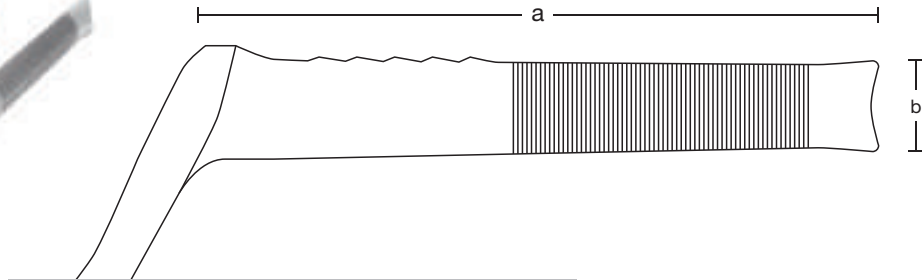

a = 80 mm	b = 11 mm	<b>58.36.40</b>
a = 90 mm	b = 13 mm	<b>58.36.41</b>
a = 100 mm	b = 15 mm	<b>58.36.42</b>

**Papavero-Caspar**

Spreizer für Spekula  
 Spreader for specula  
 Separador para espéculos  
 Ecarteur pour spéculums  
 Divaricatore per specoli

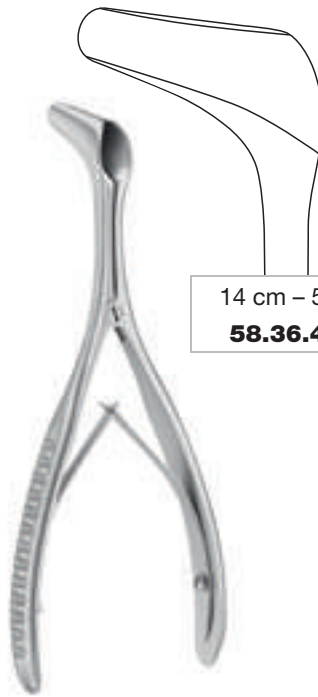

14 cm - 5½"  
**58.36.43**

**Papavero-Hartmann**

**Druckluftmotorensystem  
Pneumatic High Speed System  
Sistema de motor neumático  
Système de moteur pneumatique  
Sistema motore pneumatico**

**B11**

Das Druckluft-Motorensystem "VipAir" von Medicon wurde speziell für das Fräsen und Bohren an Schädel- bzw. Wirbelsäulenknochen konzipiert. Das System kombiniert Sicherheit und Präzision in einem ergonomischen Design mit maximaler Leistung bei kleinstmöglicher Bauweise.

The Medicon pneumatic high speed system "VipAir" was specially designed for reaming and drilling procedures at bones of the skull or spine. The system combines safety and precision in an ergonomic design with maximal power in a unit of minimal dimensions.

El sistema de motor neumático "VipAir" de Medicon ha sido concebido específicamente para el fresado y la perforación de huesos del cráneo y de la columna vertebral. El sistema concentra seguridad, precisión y la máxima potencia en un diseño ergonómico y extremadamente compacto.

Le système de moteur pneumatique "VipAir" de Medicon a été spécialement conçu pour le fraisage et le forage des os du crâne et de la colonne vertébrale. Le système allie sécurité, précision et design ergonomique à une performance maximale pour des dimensions aussi compactes que possible.

Il sistema motore pneumatico "VipAir" Medicon è ideato in particolare per fresare e perforare le ossa craniche e della colonna vertebrale. Il sistema combina sicurezza e precisione con un design ergonomico e massime prestazioni, il tutto in una struttura estremamente compatta.



**VipAir**  
PNEUMATIC HIGH SPEED SYSTEM



# B11

**Systemübersicht**  
**System Overview**  
**Vista general al sistema**  
**Aperçu du système**  
**Visione generale del sistema**

**VipAir**  
 PNEUMATIC HIGH SPEED SYSTEM

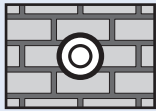

Druckluft  
 Compressed air  
 Aire comprimido  
 Air comprimé  
 Aria compressa



Fußpedal  
 Foot switch  
 Interruptor a pedal  
 Interrupteur à pédale  
 Interruttore a pedale



Trepanmotor (siehe Seite 144)  
 Trepan motor (see page 144)  
 Motor de trépano (véase página 144)  
 Moteur à trépan (voir page 144)  
 Motore trapano (vedi pagina 144)



Winkelmotor  
 Angled motor  
 Motor angulado  
 Moteur angulaire  
 Motore angolato

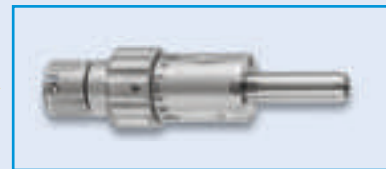

Motor mit INTRA-Kupplung  
 Motor with INTRA coupling  
 Motor con acoplamiento INTRA  
 Moteur avec embrayage INTRA  
 Motore con accoppiamento INTRA



Wandanschluss  
 Wall connection  
 Pared de conexión  
 Connexion au mur  
 Attacco parete

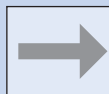

Wandschlauch  
 Wall tube  
 Tubo mural  
 Tuyau mural  
 Tubo parete

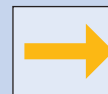

Motorschlauch  
 Motor tube  
 Tubo de motor  
 Tuyau moteur  
 Tubo motore



**Systemübersicht**  
**System Overview**  
**Vista general al sistema**  
**Aperçu du système**  
**Visione generale del sistema**

**B11**



Trepanfräser (siehe Seite 145)  
 Trepanation burrs (see page 145)  
 Fresas de trépano (véase página 145)  
 Fraises à trépan (voir page 145)  
 Punta per perforatore (vedi pagina 145)



Arbeitsaufsätze  
 Hand pieces  
 Cabezales de trabajo  
 Pièces à main  
 Inserti lavorativi

gewinkelt  
 angled  
 anguladas  
 angulaires  
 angolati

gerade  
 straight  
 rectas  
 droites  
 retti

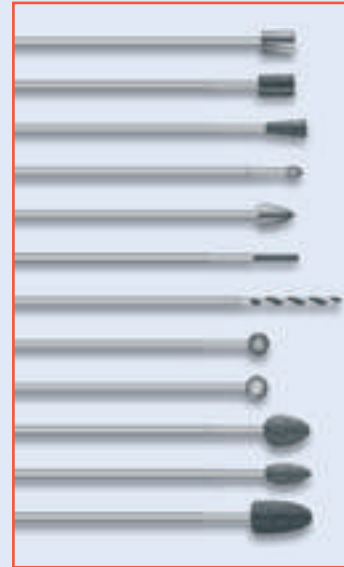

Werkzeuge  
 Tools  
 Terminales  
 Outils  
 Punte



Spülrohre  
 Irrigation tubes  
 Tubos de irrigación  
 Tuyaux d'irrigation  
 Tubi d'irrigazione

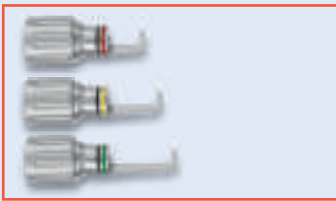

Kraniotome (siehe Seite 145)  
 Craniotomes (see page 145)  
 Cráneotomos (véase página 145)  
 Crâniotomes (voir page 145)  
 Craniotomi (vedi pagina 145)

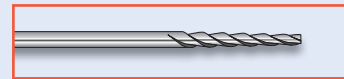

Kraniotomfräser (siehe Seite 145)  
 Craniotome burrs (see page 145)  
 Fresas para craneotomo (véase página 145)  
 Fraises pour crâniotome (voir page 145)  
 Frese per craniotomo (vedi pagina 145)



Chirurgische Handstücke und Mikrosägen  
 Surgical hand pieces and micro saws  
 Piezas de mano quirúrgicas y micro sierras  
 Pièces à main chirurgicales et micro scies  
 Manipoli chirurgici e micro seghe

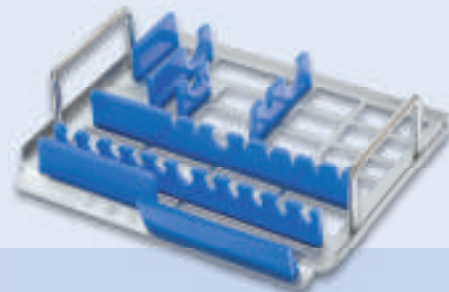



**Vorteile**  
**Advantages**  
**Ventajas**  
**Avantages**  
**Vantaggi**

**B11**

**VipAir**  
 PNEUMATIC HIGH SPEED SYSTEM

**Klein und handlich**  
**small and handy**  
**pequeño y manejable**  
**petit et maniable**  
**piccolo e maneggevole**

**ergonomisch**  
**ergonomic**  
**ergonómico**  
**ergonomique**  
**ergonomico**

**ölfrei**  
**oil free**  
**libre de aceite**  
**sans huile**  
**senza olio**

**leise**  
**quiet**  
**silencioso**  
**silencieux**  
**silenzioso**

**sicher**  
**secure**  
**seguro**  
**sûr**  
**sicuro**

**luftgekühlt**  
**air-cooled**  
**refrigerado por aire**  
**refroidissement**  
**raffreddato ad aria**



Maximale Leistung bei kleinstmöglicher Bauweise  
 Maximum performance using the smallest possible construction  
 Rendimiento máximo con una construcción compacta  
 Puissance maximale pour la plus petite construction possible  
 Rendimento massimo grazie ad una costruzione il più possibile ridotta

Ergonomie und Balance garantieren Präzision und Instrumentenkontrolle  
 Ergonomy and balance guarantee precision and instrument control  
 Ergonomía y equilibrio garantizan precisión y el control sobre el instrumento  
 Ergonomie et balance garantissant la précision et le contrôle des instruments  
 Ergonomia ed equilibrio garantiscono precisione e controllo sullo strumento

Ölfreier und wartungsfreundlicher Motor  
 Oil free motor and easy to maintain  
 Motor libre de aceite que requiere poco mantenimiento  
 Moteurs sans huile et entretien facile  
 Motore senza olio che non richiede manutenzione

Leise Motorengeräusche ermöglichen ein stressfreies Arbeiten  
 A low-noise motor ensures stressfree working environment  
 Un motor silencioso posibilita un trabajo sin estrés  
 Moteurs silencieux permettant un travail sans stress  
 Il motore silenzioso rende possibile un lavoro senza stress

Sichere und schnelle Bedienbarkeit durch MEDICON-Spezialkupplung  
 Secure and quick handling due to the MEDICON special coupling  
 Manejo rápido y seguro mediante el acoplamiento MEDICON  
 Maniement sûr et rapide par accouplement MEDICON spécial  
 Utilizzo sicuro e veloce grazie all'accoppiamento speciale MEDICON

Kühlwirkung der Druckluft verhindert ein Erwärmen des Motors  
 Cooling effect of compressed air avoids warming up of the motor  
 Refrigeración por aire comprimido evita el calentamiento del motor  
 L'effet de refroidissement par l'air comprimé empêche la surchauffe du moteur  
 L'azione refrigerante dell'aria compressa impedisce il surriscaldamento del motore

**Druckluftmotoren  
Pneumatic High Speed Motors  
Motores neumáticos  
Moteurs pneumatiques  
Motori pneumatici**

**B11**

Motor mit INTRA-Kupplung  
Motor with INTRA coupling  
Motor con acoplamiento INTRA  
Moteur avec embrayage INTRA  
Motore con accoppiamento INTRA

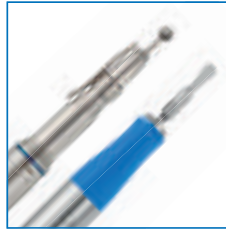

Für Standard-Chirurgiehandstücke und Mikro-Sägen  
For standard surgical hand pieces and micro saws  
Para piezas de mano quirúrgicas estándar y micro sierras  
Pour pièces à main chirurgicales standard et de micro scies  
Per l'utilizzo di manipoli chirurgici standard e micro seghe

DIN 13940  
ISO 3964



1:1

10 cm - 4" **93.00.22**

links left izquierda gauche sinistra  
rechts right derecha droite destra

Zweistufiger Rechts- und Linkslauf  
Two-stage clockwise/counter clockwise motion  
Dos etapas de funcionamiento (derecha/izquierda)  
Deux vitesses possibles tant à droite que à gauche  
Funzionamento in senso orario ed antiorario a due velocità

1. = 20.000 U/min

2. = 25.000 U/min

- ▶ Sehr leiser und vibrationsfreier Lauf
- ▶ Kleine Bauweise, geringes Gewicht und stark im Durchzug
- ▶ Zweistufiger Rechts- und Linkslauf
- ▶ Quiet and without vibrations
- ▶ Small, lightweight construction and powerful torque
- ▶ Two-stage clockwise/counter clockwise motion
- ▶ Muy silencioso y sin vibraciones durante el uso
- ▶ Construcción ergonómica, poco peso y momento de giro muy elevado
- ▶ Dos etapas de funcionamiento (derecha/izquierda)
- ▶ Silencieux et sans vibration
- ▶ Construction micro, poids léger et puissance de rotation élevée
- ▶ Deux vitesses possibles tant à droite que à gauche
- ▶ Funzionamento molto silenzioso e privo di vibrazioni
- ▶ Dimensioni ridotte, peso minimo ed elevato momento torcente
- ▶ Funzionamento in senso orario ed antiorario a due velocità

Technische Daten Technical data Especificaciones técnicas Caractéristiques techniques Dati tecnici	Drehzahl bei 8 bar Revolutions per minute at 8 bar Número de revoluciones a 8 bar Nombre de tours à 8 bar Numero di giri a 8 bar	Drehmoment bei 8 bar Torque at 8 bar Momento de giro a 8 bar Couple à 8 bar Momento torcente a 8 bar	Leistung bei 8 bar Output at 8 bar Potencia a 8 bar Puissance à 8 bar Potenza a 8 bar	Empfohlener Druck Recommended pressure Presión recomendada Pression recommandée Pressione raccomandata	Freigegebener Druck Approved pressure Presión permitida Pression libérée Pressione permessa
<b>93.00.22</b>	20.000-25.000 U/min	4,0 Ncm	44 Watt	8 bar	8±2 bar

**B11**

**Druckluftmotoren**  
**Pneumatic High Speed Motors**  
**Motores neumáticos**  
**Moteurs pneumatiques**  
**Motori pneumatici**

**VipAir**  
 PNEUMATIC HIGH SPEED SYSTEM

Winkelmotor  
 Angled motor  
 Motor angulado  
 Moteur angulaire  
 Motore angolato

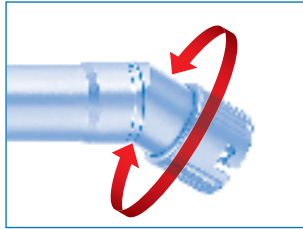

Das drehbare Winkelstück verhindert ein Verwinden des Motorschlauches  
 The rotatable elbow avoids a torsion of the motor tube  
 La pieza de mano giratoria evita una torsión del tubo de motor  
 Le coude à plat pivotant empêche une torsion du tuyau moteur  
 Il raccordo girevole impedisce una torsione del tubo motore

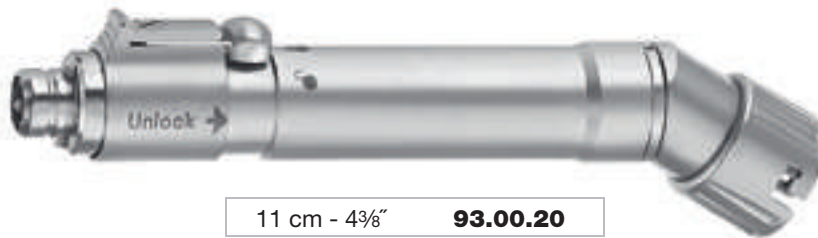

11 cm - 4 $\frac{3}{8}$ " **93.00.20**

entsichert  
 unlocked  
 desasegurado  
 déverrouillé  
 sbloccare

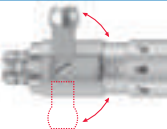

gesichert  
 locked  
 asegurado  
 verrouillé  
 bloccare



Sicherungsriegel der Kupplung  
 Safety lock of coupling  
 Pasador de seguridad del acoplamiento  
 Embayage à verrou de sécurité  
 Chiusura di sicurezza dell'accoppiamento

Technische Daten Technical data Especificaciones técnicas Caractéristiques techniques Dati tecnici	Drehzahl bei 8 bar Revolutions per minute at 8 bar Número de revoluciones a 8 bar Nombre de tours à 8 bar Numero di giri a 8 bar	Drehmoment bei 8 bar Torque at 8 bar Momento de giro a 8 bar Couple à 8 bar Momento torcente a 8 bar	Leistung bei 8 bar Output at 8 bar Potencia a 8 bar Puissance à 8 bar Potenza a 8 bar	Empfohlener Druck Recommended pressure Presión recomendada Pression recommandée Pressione raccomandata	Freigegebener Druck Approved pressure Presión permitida Pression libérée Pressione permessa
<b>93.00.20</b>	100.000 U/min	2,8 Ncm	60 Watt	6-8 bar	8±2 bar

**Arbeitsaufsätze und Spülrohre**  
**Hand Pieces and Irrigation Tubes**  
**Cabezales de trabajo y tubos de irrigación**  
**Pièces à main et tuyaux d'irrigation**  
**Inserti lavorativi e tubi d'irrigazione**

**B11**

Arbeitsaufsätze  
 Hand pieces  
 Cabezales de trabajo  
 Pièces à main  
 Inserti lavorativi



1:1

a = 20 mm	a = 40 mm	a = 60 mm	a = 80 mm	a = 100 mm
<b>S</b>	<b>M</b>	<b>L</b>	<b>XL</b>	<b>XXL</b>
<b>93.00.40</b>	<b>93.00.42</b>	<b>93.00.44</b>	<b>93.00.46</b>	<b>93.00.48</b>

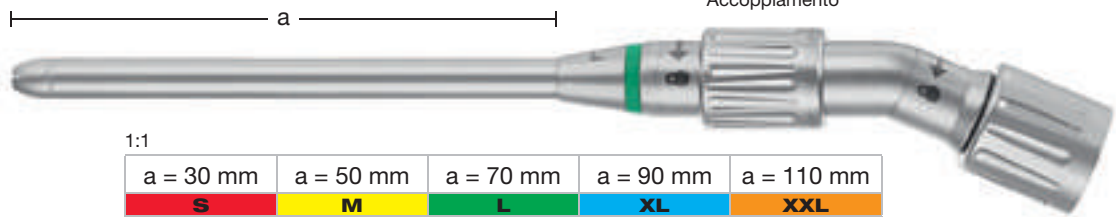
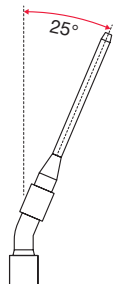

Kupplung  
 Coupling  
 Acoplamiento  
 Embrayage  
 Accoppiamento

1:1

a = 30 mm	a = 50 mm	a = 70 mm	a = 90 mm	a = 110 mm
<b>S</b>	<b>M</b>	<b>L</b>	<b>XL</b>	<b>XXL</b>
<b>93.00.50</b>	<b>93.00.52</b>	<b>93.00.54</b>	<b>93.00.55</b>	<b>93.00.56</b>

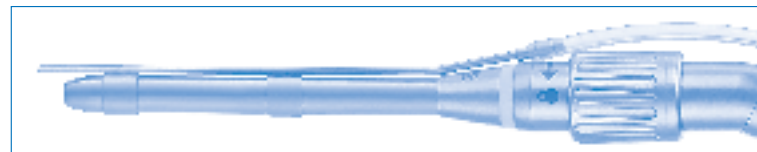

Spülrohre  
 Irrigation tubes  
 Tubos de irrigación  
 Tuyaux d'irrigation  
 Tubi d'irrigazione



1:1

a = 45 mm	a = 55 mm	a = 75 mm	a = 90 mm	a = 115 mm
<b>S</b>	<b>M</b>	<b>L</b>	<b>XL</b>	<b>XXL</b>
<b>93.00.70</b>	<b>93.00.72</b>	<b>93.00.74</b>	<b>93.00.76</b>	<b>93.00.78</b>



**Werkzeuge**  
**Tools**  
**Terminales**  
**Outils**  
**Punte**

**B11**

**VipAir**  
PNEUMATIC HIGH SPEED SYSTEM

Diamant-Kugelfräser  
Diamond dust burrs  
Fresas redondas de diamante  
Fraises forme boule diamantées  
Frese a pallina diamantate

**STERILE | R**

normal  
regular  
normal  
normale  
normale



1:1

S	M	L	XL	XXL	
93.01.20	93.02.01	93.03.01	93.06.01	93.04.01	Ø 1,0 mm
93.01.22	93.02.03	93.03.03			Ø 1,8 mm
			93.06.03	93.04.03	Ø 2,0 mm
	93.02.05	93.03.05			Ø 2,3 mm
93.01.01	93.02.07	93.03.07	93.06.07	93.04.07	Ø 3,1 mm
93.01.03	93.02.09	93.03.09	93.06.09	93.04.09	Ø 4,0 mm
93.01.05	93.02.11	93.03.08	93.06.11	93.04.21	Ø 5,0 mm
93.01.07	93.02.13	93.03.10	93.06.13	93.04.23	Ø 6,0 mm

grob  
abrasivo  
abrasivo  
abrasivo  
abrasivo



1:1

S	M	L	XL	XXL	
	93.02.66	93.03.66			Ø 5,0 mm
	93.02.68	93.03.68			Ø 6,0 mm

Diamant-Walzenfräser  
Diamond cutting burrs, barrel style  
Fresas cilíndricas de diamante  
Fraises cylindriques diamantées  
Frese cilindriche diamantate

**STERILE | R**

1:1

S	M	L	XL	XXL	
	93.02.54				Ø 3,0 mm
	93.02.52	93.03.50			Ø 6,0 mm

Rosenbohrer  
Rosen burrs  
Brocas Rosen  
Fraises Rosen  
Perforatori di Rosen

**STERILE | R**

1:1

S	M	L	XL	XXL	
	93.02.45				Ø 1,0 mm
	93.02.17	93.03.11			Ø 1,8 mm
			93.07.03	93.05.03	Ø 2,0 mm
	93.02.19	93.03.13			Ø 2,3 mm
93.01.09	93.02.21	93.03.15	93.07.05	93.05.07	Ø 3,1 mm
93.01.11	93.02.23	93.03.17	93.07.07	93.05.09	Ø 4,0 mm
93.01.13	93.02.25	93.03.19	93.07.08	93.05.11	Ø 5,0 mm
93.01.23	93.02.30	93.03.20	93.07.09	93.05.13	Ø 6,0 mm



mit Diamantkörnung  
with diamond grit  
con granulación de diamante  
avec grains de diamant  
con granulazione di diamante



mit blanker Stirnfläche  
with polished front part  
con superficie frontal lisa  
avec partie frontale lisse  
con superficie frontale liscia



Walzenfräser  
Cutting burrs, barrel style  
Fresas cilíndricas  
Fraises cylindriques  
Frese cilindriche

**STERILE | R**



1:1

S	M	L	XL	
	<b>93.02.41</b>			Ø 3,0 mm
	<b>93.02.43</b>	<b>93.03.23</b>		Ø 6,0 mm

Wirbelkörperfräser  
Vertebra burrs  
Fresas para vértebras  
Fraises vertébrales  
Frese per vertebre

**STERILE | R**



1:1

S	M	L	XL	
	<b>93.02.35</b>	<b>93.03.35</b>		Ø 5,0 mm

Neurofräser  
Neuro burrs  
Fresas neuro  
Fraises neuro  
Frese neuro

**STERILE | R**



1:1

S	M	L	XL	
	<b>93.02.31</b>	<b>93.03.21</b>		Ø 2,1 mm
	<b>93.02.32</b>	<b>93.03.22</b>	<b>93.06.30</b>	Ø 3,0 mm

Fräser  
Burrs  
Fresas "Flameshape"  
Fraises  
Frese

**STERILE | R**



1:1

S	M	L	XL	
	<b>93.02.37</b>			Ø 3,0 mm
	<b>93.02.39</b>			Ø 6,0 mm

Zementbohrer  
Cement drill  
Broca para cemento  
Fraise à ciment  
Perforatore per cemento

**STERILE | R**



1:1

S	M	L	XL	
	<b>93.02.33</b>			Ø 2,4 mm

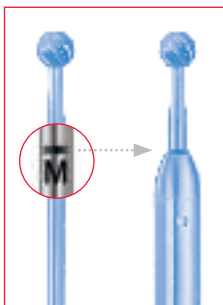

Alle Werkzeuge besitzen eine Markierung zur schnellen und sicheren Positionierung des Werkzeuges im Arbeitsaufsatz und eine Längenangabe (S, M, L, XL, XXL) zur besseren Unterscheidung.

All tools have a marking for a quick and secure positioning of the tool into the hand piece as well as an indication of length (S, M, L, XL, XXL) for a better distinction.

Los terminales disponen de una marca para el posicionamiento rápido y seguro en el cabezal. Esta marca sirve también como indicación de longitud (S, M, L, XL, XXL).

Tous les outils ont un marquage permettant une positionnement sûr et rapide dans les inserts, et un marquage de taille (S, M, L, XL, XXL) pour un meilleur choix.

Tutte le punte presentano una marcatura per posizionarle velocemente ed in modo sicuro negli inserti. La stessa marcatura serve anche a distinguere meglio la lunghezza (S, M, L, XL, XXL).



mit Diamantkörnung  
with diamond grit  
con granulación de diamante  
avec grains de diamant  
con granulazione di diamante



**Werkzeuge**  
**Tools**  
**Terminales**  
**Outils**  
**Punte**

**B11**

**VipAir**  
PNEUMATIC HIGH SPEED SYSTEM

Spiralbohrer  
Twist drills  
Brocas espirales  
Fraises en spirale  
Perforatori a spirale

**STERILE | R**

1:1

S	M	L	XL	
93.01.17	93.02.47	93.03.40	93.06.08	Ø 1,5 mm
93.01.19	93.02.49			Ø 2,0 mm

Dermabrasionsfräser  
Burs for dermabrasion  
Fresas para la dermoabrasión  
Fraises à dermabrasion  
Frese per la dermoabrasione

**STERILE | R**

feinkörnig  
fine-grained  
de grano fino  
à grains fins  
granuloso



1:1

M	
93.02.20	Ø 9 mm

feinkörnig  
fine-grained  
de grano fino  
à grains fins  
granuloso



1:1

M	
93.02.22	Ø 6 mm

grobkörnig  
coarse-grained  
de grano grueso  
à gros grains  
grossolano



1:1

M	
93.02.24	Ø 10 mm

Spritzschutz für die Dermabrasion  
Splash guard for dermabrasion  
Protección contra riego para la dermoabrasión  
Protection anti-projections à dermabrasion  
Protezione antispruzzo per la dermoabrasione

Luer-Lock



1:1

4,5 cm - 1¾" **93.00.60**

Schützt das Operationsfeld vor Verunreinigung  
Protects the operation area from contamination  
Protege el campo operatorio de ensuciamiento  
Protège le champ opératoire des projections  
Protegge il campo operatorio dalle impurità



mit Diamantkörnig  
with diamond grit  
con granulacion de diamante  
avec grains de diamant  
con granulazione di diamante



**Fußpedal und Schläuche**  
**Foot Switch and Tubes**  
**Interruptor a pedal y tubos**  
**Interrupteur à pédale et tuyaux**  
**Interruttore a pedale e tubi**

**B11**

Fußpedal  
 Foot switch  
 Interruptor a pedal  
 Interrupteur à pédale  
 Interruttore a pedale



110 × 200 × 140 mm  
**93.00.10**

Wandschläuche  
 Wall tubes  
 Tubos murales  
 Tuyaux muraux  
 Tubi parete



 "OPEN-END" **93.00.00** 4,5 m 



 "DRAEGER" **93.00.02** 4,5 m 



 "SYNTHES" **93.00.04** 4,5 m 

Motorschlauch  
 Motor tube  
 Tubo de motor  
 Tuyau moteur  
 Tubo motore



 **93.00.15** 2,5 m 

**B11**

**Zubehör**  
**Accessories**  
**Accesorios**  
**Accessoires**  
**Accessori**

**VipAir**  
 PNEUMATIC HIGH SPEED SYSTEM

Reinigungs-Tray für die maschinelle Reinigung  
 Cleaning tray for mechanical cleaning  
 Bandeja de limpieza para la limpieza automática  
 Tray de nettoyage pour nettoyage en machine  
 Supporto di pulizia per la pulizia a macchina

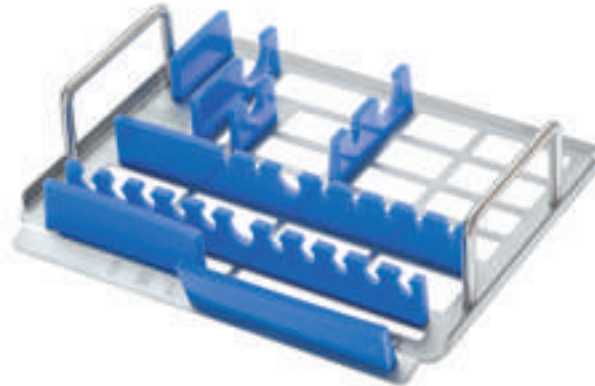
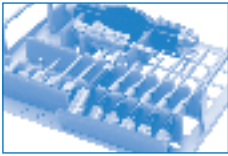
240 × 200 × 60 mm **93.00.83**

Doppelcontainer  
 Double container  
 Contenedor doble  
 Container double  
 Contenitore doppio

502 × 239 × 102 mm **93.00.85**

Werkzeugkassette mit Silikonmatte  
 Tools tray including silicon mat  
 Caja para terminales con estera de silicona  
 Cassette pour outils avec tapis en silicone  
 Cassetta per attrezzi con tappetino in silicone

190 × 102 × 19 mm **49.90.00**

Motorschmiermittel  
 Lubrication of the motor  
 Lubrificante para el motor  
 Lubrifiant pour le moteur  
 Lubrificante per motore

500 ml **63.69.96**

Sprühadapter  
 Spray adaptor  
 Adaptador de spray  
 Adaptateur du spray  
 Adattatore per spray



1:1

35 mm / Ø 9 mm **93.00.80**

Kunststoff (autoklavierbar bis 134 °C bei 3 bar)  
 Plastic (autoclavable up to 134 °C at 3 bar)  
 Plástico (autoclavable hasta 134 °C bajo presión de 3 bar)  
 Plastique (autoclavable à 134 °C sous pression de 3 bars)  
 Plastica (autoclavabile fino a 134 °C sotto pressione di 3 bar)



Siebvorschläge  
Set Suggestions  
Proposiciones de juegos  
Propositions pour boîtes  
Proposte di set

C

neuro  
**CRANIALIS**

**Siebvorschläge**  
**Set Suggestions**  
**Proposiciones de juegos**  
**Propositions pour boîtes**  
**Proposte di set**

<b>C01</b>	Siebvorschlag für die Schädelöffnung Set Suggestion for craniotomy Proposición de juego para la apertura del cráneo Proposition à boîte pour l'ouverture du crâne Proposta di set per l'apertura del cranio	279
<b>C02</b>	Siebvorschlag für Eingriffe an der hinteren Schädelgrube Set suggestion for procedures of the posterior cranial fossa Proposición de juego para los procedimientos en la fosa posterior del cráneo Proposition pour boîte pour les procédures sur fosse postérieure du crâne Proposta di set per le procedure sulla fossa cranica posteriore	281
<b>C03</b>	Siebvorschlag für Eingriffe am Schädel Set suggestion for procedures of the skull Proposición de juego para los procedimientos en el cráneo Proposition à boîte pour les procédures sur le crâne Proposta di set per le procedure sul cranio	282
<b>C04</b>	Siebvorschlag für die kraniale Mikrochirurgie Set suggestion for cranial microsurgery Proposición de juego para microcirugía craneal Proposition à boîte de microchirurgie crânienne Proposta di set per la microchirurgia cranica	285
<b>C05</b>	Siebvorschlag für Hydrocephalus Shunt Set suggestion for hydrocephalus shunt Proposición de juego de Shunt para hidrocefalia Proposition à boîte pour Shunt hydrocéphalie Proposta di set per l'idrocefalo Shunt	286
<b>C06</b>	Siebvorschlag für Handinstrumente der peripheren Nerven Set suggestion for hand instruments of the peripheral nerves Proposición de juego para instrumentos de mano de los nervios periféricos Proposition à boîte pour instruments à main des nerfs périphériques Proposta di set per strumenti della mano dei nervi periferici	288
<b>C07</b>	Siebvorschlag für die transspheoidale Hypophysektomie Set suggestion for transspheoidal hypophysectomy Proposición de juego para la hipofisectomía transesfenoidal Proposition à boîte pour l'hypophysectomie transsphénoïdale Proposta di set per l'ipofisectomia transfenoidale	290

**Siebvorschlag für die Schädelöffnung**  
**Set Suggestion for Craniotomy**  
**Proposición de juego para la apertura del cráneo**  
**Proposition à boîte pour l'ouverture du crâne**  
**Proposta di set per l'apertura del cranio**

**C01**

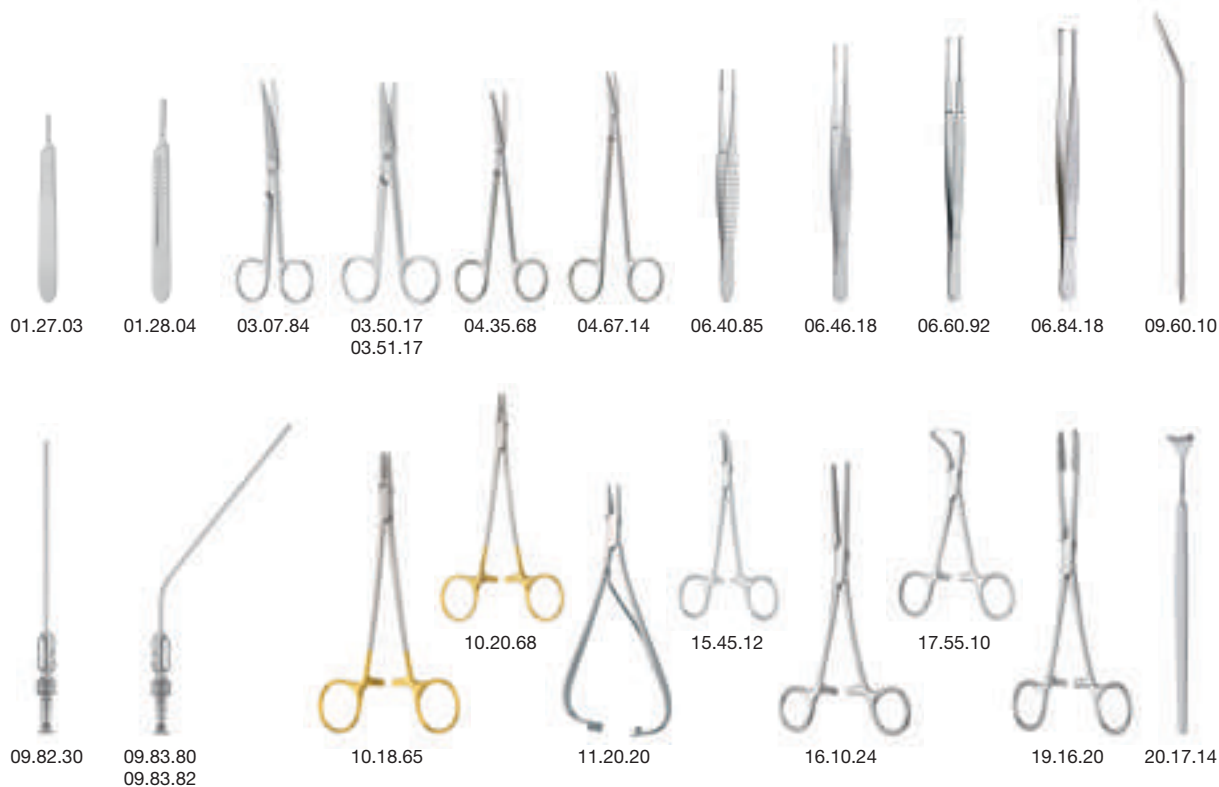

**PART 1**

Item number	Description	Quantity
01.27.03	Scalpel handle · no 3 · standard · 12.5 cm	1
01.28.04	Scalpel handle · no 4 · standard · 13.5 cm	2
03.07.84	Surgical scissors · delicate · curved · blunt / sharp · 14.5 cm	1
03.50.17	MAYO Scissors · straight · 17 cm	1
03.51.17	MAYO Scissors · curved · 17 cm	1
04.35.68	METZENBAUM-SLIM "HM" Scissors · curved · 18 cm	1
04.67.14	REYNOLDS (JAMESON) Scissors · curved · 14 cm	1
06.40.85	GILLIES Tissue forceps · 1 x 2 teeth · 15 cm	1
06.46.18	POTTS-SMITH Dressing forceps · serrated · 18 cm	2
06.60.92	GERALD Tissue forceps · straight · 1 x 2 teeth · 18 cm	1
06.84.18	STILLE-BARRAYA Tissue forceps · 18 cm	1
09.60.10	REDON Guide needle · slightly curved · knife tip · threaded end · 10 French	1
09.82.30	FRAZIER Suction cannula · straight · 10 French · 12.5 cm	2
09.83.80	FRAZIER (FERGUSON) Suction cannula · angled · 10 French · 18 cm	1
09.83.82	FRAZIER (FERGUSON) Suction cannula · angled · 12 French · 18 cm	1
10.18.65	MAYO-HEGAR "HM" Needle holder · 16 cm	1
10.20.68	CRILE-WOOD "HM" (DEBAKEY "HM") Needle holder · 18 cm	1
11.20.20	MATHIEU Needle holder · 20 cm	1
15.45.12	HALSTED-MOSQUITO Forceps · curved · 12.5 cm	5
16.10.24	ROCHESTER-PEAN Hemostatic forceps · straight · 24 cm	3
17.55.10	BACKHAUS Towel clamp · 10.5 cm	10
19.16.20	GROSS Dressing forceps · straight · 20 cm	3
20.17.14	CUSHING Vein hook · 14 mm · 20 cm	2



**C01**

**Siebvorschlag für die Schädelöffnung**  
**Set Suggestion for Craniotomy**  
**Proposición de juego para la apertura del cráneo**  
**Proposition à boîte pour l'ouverture du crâne**  
**Proposta di set per l'apertura del cranio**

**PART 2**

Item number	Description	Quantity
<b>20.65.03</b>	Tracheal retractor · 3 teeth · blunt · 10 mm · 16 cm	1
<b>22.42.04</b>	KOCHER Retractor · 4 teeth · sharp · 18 mm · 22 cm	1
<b>24.22.14</b>	WEITLANER Retractor · 3 × 4 teeth · blunt · 13 cm	1
<b>24.30.14</b>	WEITLANER-BECKMANN Retractor · blunt · 14.5 cm	1
<b>26.54.10</b>	LAMBOTTE Raspatory · 10 mm · 22 cm	1
<b>29.52.42</b>	SCHEDE Sharp curette · figure 2/0 · 17 cm	1
<b>31.09.93</b>	Bone rongeur · slender pattern · angled sideways · 23 cm	1
<b>31.11.13</b>	MARQUARDT Bone rongeur · curved · 20 cm	1
<b>57.34.16</b>	TOENNIS Hook · 17 cm	1
<b>57.36.14</b>	DAVIS Dissector · double-ended · 4 / 5 mm · 25 cm	1
<b>57.64.02</b>	GIGLI Wire saw handles · solid · packing unit 2 pieces	2
<b>57.64.30</b>	GIGLI (OLIVECRONA) Wire saw · packing unit 5 pieces · 30 cm	2
<b>57.64.90</b>	DEMARTEL (BAILEY) Wire saw guide · 33 cm	1
<b>57.85.03A</b>	RANEY Scalp clip · packing unit 200 pieces	1
<b>57.85.07</b>	RANEY Scalp clip forceps · 16 cm	1
<b>→ 57.85.50</b>	<b>MOD. KÖLN Clip · packing unit 10 pieces</b>	<b>1</b>
<b>67.15.35</b>	YANKAUER Septum elevator · 6 mm · 18 cm	1
<b>49.60.17</b>	Medicontainer · silver · 590 × 290 × 170 mm	1
<b>49.97.12</b>	Wire basket · 480 × 255 × 50 mm	3



Das komplette Instrumentarium für die Trepanation und Kraniotomie finden Sie im Abschnitt B03  
 For the complete range of instruments for trepanation and craniotomy please see section B03  
 El instrumental completo para la trepanación y la craneotomía se encuentra en la sección B03  
 Vous trouverez l'instrument complet pour la trépanation et la craniotomie dans la section B03  
 Troverete lo strumentario completo per la trapanazione e la craniotomia nella sezione B03



Instrumente, optional  
 Instruments optional  
 Instrumentos opcional  
 Instruments optionnel  
 Strumenti opzionale

**Siebvorschlag für Eingriffe an der hinteren Schädelgrube**  
**Set Suggestion for Procedures of the Posterior Cranial Fossa**  
**Proposición de juego para los procedimientos en la fosa posterior del cráneo**  
**Proposition pour boîte pour les procédures sur fosse postérieure du crâne**  
**Proposta di set per le procedure sulla fossa cranica posteriore**

**C02**

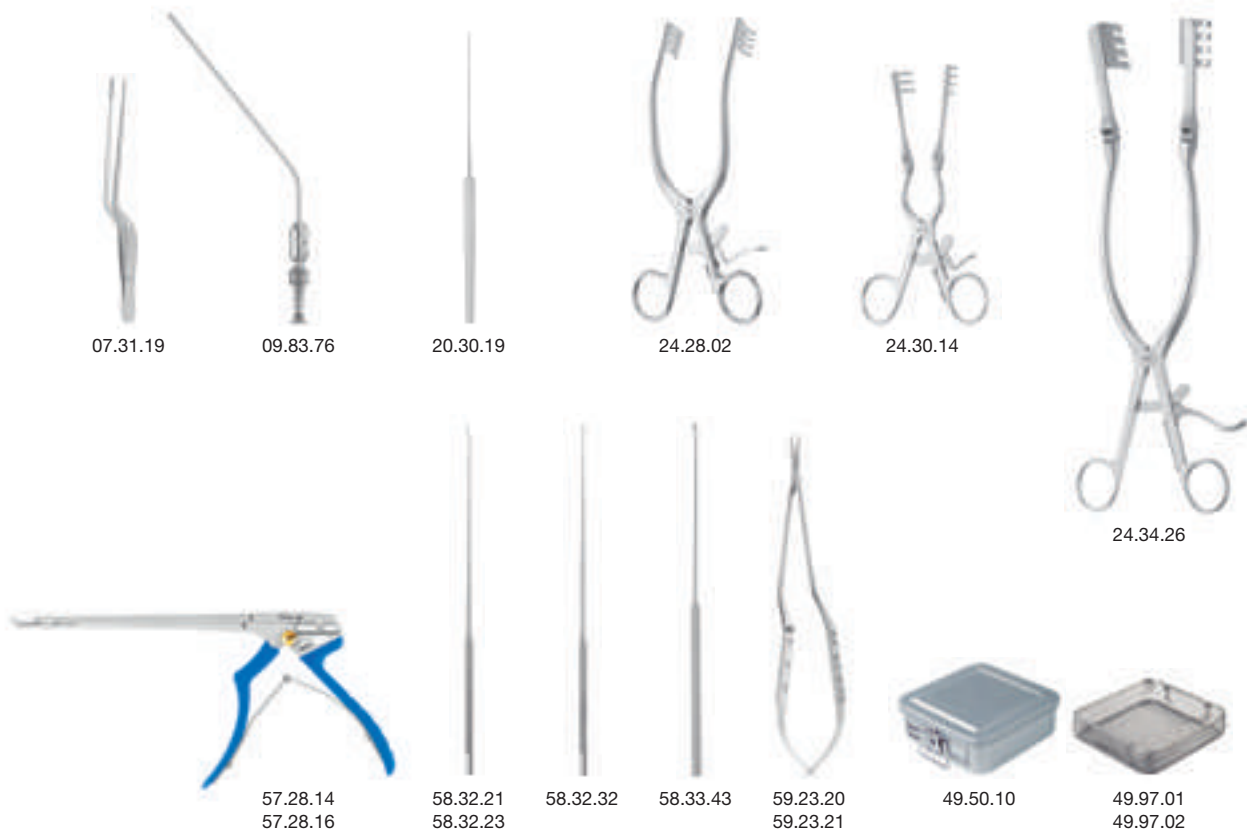

Item number	Description	Quantity
<b>07.31.19</b>	GRUENWALD Bayonet forceps · 1 x 2 teeth · 19.5 cm	2
<b>09.83.76</b>	FRAZIER (FERGUSSON) Suction cannula · angled · 6 French · 18 cm	1
<b>20.30.19</b>	GILLIES Hook · small · 19 cm	1
<b>24.28.02</b>	ADSON-ANDERSON Retractor · angled · sharp · 19 cm	2
<b>24.30.14</b>	WEITLANER-BECKMANN Retractor · blunt · 14.5 cm	2
<b>24.34.26</b>	BECKMANN-ADSON Retractor · blunt · 25 mm · 31 cm	2
<b>57.28.14</b>	KERRISON Rongeur · dismantable · angled upwards 40° · 4 mm · 20 cm	1
<b>57.28.16</b>	KERRISON Rongeur · dismantable · angled upwards 40° · 6 mm · 20 cm	1
<b>58.32.21</b>	Micro dissector · 1.0 mm · 23 cm	1
<b>58.32.23</b>	Micro dissector · 1.8 mm · 23 cm	1
<b>58.32.32</b>	Micro tumor knife · Ø 2 mm · 23 cm	1
<b>58.33.43</b>	SAMII Tumor knife · Ø 4.5 mm · 23 cm	1
<b>59.23.20</b>	YASARGIL Micro scissors · bayonet · straight · 23 cm	1
<b>59.23.21</b>	YASARGIL Micro scissors · bayonet · angled · 23 cm	1
<b>49.50.10</b>	Medicontainer · silver · 290 x 290 x 100 mm	1
<b>49.97.01</b>	Wire basket · 240 x 255 x 30 mm	1
<b>49.97.02</b>	Wire basket · 240 x 255 x 50 mm	1

**C03**

**Siebvorschlag für Eingriffe am Schädel**  
**Set Suggestion for Procedures of the Skull**  
**Proposición de juego para los procedimientos en el cráneo**  
**Proposition à boîte pour les procédures sur le crâne**  
**Proposta di set per le procedure sul cranio**

**PART 1**

Item number	Description	Quantity
<b>01.27.03</b>	Scalpel handle · no 3 · standard · 12.5 cm	1
<b>01.28.04</b>	Scalpel handle · no 4 · standard · 13.5 cm	2
<b>03.07.84</b>	Operating scissors · delicate · curved · sharp / blunt · 14.5 cm	1
<b>03.50.17</b>	MAYO Scissors · straight · 17 cm	1
<b>03.51.17</b>	MAYO Scissors · curved · 17 cm	1
<b>04.35.68</b>	METZENBAUM-SLIM "HM" Scissors · curved · 18 cm	1
<b>04.67.14</b>	REYNOLDS (JAMESON) Scissors · curved · 14 cm	1
<b>06.05.20</b>	Tissue forceps · standard · 1 × 2 teeth · 20 cm	1
<b>06.23.15</b>	MICRO-ADSON Tissue forceps · 1 × 2 teeth · 15 cm	1
<b>06.43.15</b>	WAUGH Tissue forceps · cross threads · 1 × 2 teeth · 15 cm	2
<b>06.46.18</b>	POTTS-SMITH Dressing forceps · serrated · 18 cm	2
<b>06.48.18</b>	POTTS-SMITH Tissue forceps · 1 × 2 teeth · 18 cm	1
<b>06.60.92</b>	GERALD Tissue forceps · straight · 1 × 2 teeth · 18 cm	2
<b>06.84.18</b>	STILLE-BARRAYA Tissue forceps · 18 cm	2
<b>09.60.10</b>	REDON Guide needle · slight curved · knife tip · threaded end · 10 French	1
<b>09.82.30</b>	FRAZIER Suction cannula · 10 French · straight · 12.5 cm	2
<b>09.83.78</b>	FRAZIER (FERGUSON) Suction cannula · 8 French · angled · 18 cm	1
<b>09.83.80</b>	FRAZIER (FERGUSON) Suction cannula · 10 French · angled · 18 cm	1
<b>09.83.82</b>	FRAZIER (FERGUSON) Suction cannula · 12 French · angled · 18 cm	2
<b>10.18.65</b>	MAYO-HEGAR "HM" Needle holder · 16 cm	1
<b>10.20.68</b>	CRILE-WOOD "HM" (DEBAKEY "HM") Needle holder · fine · 18 cm	1





**Siebvorschlag für Eingriffe am Schädel**  
**Set Suggestion for Procedures of the Skull**  
**Proposición de juego para los procedimientos en el cráneo**  
**Proposition à boîte pour les procédures sur le crâne**  
**Proposta di set per le procedure sul cranio**

**C03**



**PART 2**

Item number	Description	Quantity
11.20.70	MATHIEU "HM" Needle holder · 20 cm	1
15.45.12	HALSTED-MOSQUITO Forceps · curved · 12.5 cm	10
16.10.24	ROCHESTER-PEAN Hemostatic forceps · straight · 24 cm	6
16.11.84	DANDY Hemostatic forceps · curved sideways · 14 cm	15
16.85.14	MIKULICZ-BABY Peritoneum forceps · 14.5 cm	15
17.55.10	BACKHAUS Towel clamp · 10.5 cm	10
19.16.20	GROSS Dressing forceps · straight · 20 cm	2
19.17.26	MAIER Dressing forceps · curved · 26 cm	6
20.65.03	Tracheal retractor · 3 teeth · blunt · 10 mm · 16 cm	1
22.42.04	KOCHER Retractor · 4 teeth · sharp · 18 mm · 22 cm	2
24.22.14	WEITLANER Retractor · 3 × 4 teeth · sharp · 13 cm	2
26.23.04	SEBILEAU Elevator · 4 mm · 16.5 cm	1
26.44.25	LEMPERT Raspatory · 5 mm · 17 cm	1
26.54.10	LAMBOTTE Raspatory · 10 mm · 22 cm	1
26.54.15	LAMBOTTE Raspatory · 15 mm · 22 cm	1
29.52.42	SCHEDÉ Sharp curette · figure 2/0 · 17 cm	1
46.28.15	BUNT Instrument holder · 12 cm	4
46.37.50	Needle case · Ø 65 mm	1
46.37.51	Inner case only · for 46.37.50	1
57.29.20	DAVIS Brain spatula · malleable · 16 mm · 19 cm	1
57.31.59	OLIVECRONA Spatula · straight · 7 mm / 9 mm · 18 cm	1
57.34.16	TOENNIS Hook · 17 cm	1



**C03**

**Siebvorschlag für Eingriffe am Schädel**  
**Set Suggestion for Procedures of the Skull**  
**Proposición de juego para los procedimientos en el cráneo**  
**Proposition à boîte pour les procédures sur le crâne**  
**Proposta di set per le procedure sul cranio**

**PART 3**

Item number	Description	Quantity
<b>57.34.16</b>	TOENNIS Hook · 17 cm	1
<b>57.36.14</b>	DAVIS Dissector · double-ended · 4 mm / 5 mm · 25 cm	1
<b>57.64.02</b>	GIGLI Wire saw handles · solid · packing unit 2 pieces	2
<b>57.64.30</b>	GIGLI (OLIVECRONA) Wire saw · packing unit 5 pieces · 30 cm	2
<b>57.64.90</b>	DE MARTEL (BAILEY) Wire saw guide · 33 cm	1
<b>57.85.03A</b>	RANEY Scalp clip · packing unit 200 pieces	1
<b>57.85.07</b>	RANEY Scalp clip forceps · 16 cm	1
<b>57.85.10</b>	YASARGIL Galea hook · 31 cm	5
<b>57.85.11</b>	YASARGIL Galea hook · 41 cm	5
<b>→ 57.85.50</b>	MOD. KÖLN Clip · packing unit 10 pieces	1
<b>59.44.05</b>	YASARGIL Grasping forceps · Ø 5 mm · 22 cm	1
<b>59.44.73</b>	YASARGIL Grasping forceps · Ø 3 mm · 22 cm	1
<b>59.44.75</b>	YASARGIL Grasping forceps · Ø 5 mm · 22 cm	1
<b>67.15.35</b>	YANKAUER Septum elevator · 6 mm · 18 cm	1
<b>49.60.17</b>	Medicontainer · silver · 590 × 290 × 170 mm	1
<b>49.97.12</b>	Wire basket · 480 × 255 × 50 mm	3



Das komplette Instrumentarium für die Trepanation und Kraniotomie finden Sie im Abschnitt B03  
 For the complete range of instruments for trepanation and craniotomy please see section B03  
 El instrumental completo para la trepanación y la craneotomía se encuentra en la sección B03  
 Vous trouverez l'instrument complet pour la trépanation et la craniotomie dans la section B03  
 Troverete lo strumentario completo per la trapanazione e la craniotomia nella sezione B03



Instrumente, optional  
 Instruments optional  
 Instrumentos opcional  
 Instruments optionnel  
 Strumenti opzionale

**Siebvorschlag für die kraniale Mikrochirurgie**  
**Set Suggestion for Cranial Microsurgery**  
**Proposición de juego para microcirugía craneal**  
**Proposition à boîte de microchirurgie crânienne**  
**Proposta di set per la microchirurgia cranica**

**C04**



Item number	Description	Quantity
<b>09.83.76</b>	FRAZIER (FERGUSSON) Suction cannula · angled · 6 French · 18 cm	1
<b>58.19.27</b>	YASARGIL Micro scissors · angled · buttoned · 18 cm	1
<b>58.30.01</b>	JACOBSON Vessel knife · 18.5 cm	1
<b>58.30.10</b>	YASARGIL Raspatory · angled · 1 mm · 18.5 cm	1
<b>58.30.17</b>	YASARGIL Raspatory · slightly curved · 2.5 mm · 18.5 cm	1
<b>58.30.20</b>	JACOBSON Probe · ball tip · angled · 18.5 cm	1
<b>58.30.32</b>	KRAYENBÜHL Hook · 3.5 mm · 18.5 cm	1
<b>58.30.35</b>	KRAYENBÜHL Hook · 2.0 mm · 18.5 cm	1
<b>58.30.36</b>	KRAYENBÜHL Hook · 2.5 mm · 18.5 cm	1
<b>58.32.04</b>	Hook · sharp · 2.5 mm · 18.5 cm	1
<b>58.32.21</b>	Micro dissector · 1.0 mm · 23 cm	1
<b>58.32.22</b>	Micro dissector · 1.4 mm · 23 cm	1
<b>58.32.23</b>	Micro dissector · 1.8 mm · 23 cm	1
<b>58.33.35</b>	SAMII Tumor knife · 3.0 mm · 23 cm	1
<b>58.33.42</b>	SAMII Tumor knife · Ø 3.0 mm · 23 cm	1
<b>59.20.20</b>	YASARGIL Micro scissors · bayonet · straight · 20 cm	1
<b>59.20.21</b>	YASARGIL Micro scissors · bayonet · angled · 20 cm	1
<b>59.23.10</b>	YASARGIL Micro forceps · bayonet · sharp · 0.6 mm · 23 cm	1
<b>59.23.14</b>	YASARGIL Micro forceps · bayonet · blunt · 0.9 mm · 23 cm	1
<b>49.50.10</b>	Medicontainer · silver · 290 × 290 × 100 mm	1
<b>49.97.02</b>	Wire basket · 240 × 255 × 50 mm	2
<b>49.97.72</b>	Silicon mat · distance between naps 3 mm · 240 × 220 mm	2

**C05**

**Siebvorschlag für Hydrocephalus Shunt**  
**Set Suggestion for Hydrocephalus Shunt**  
**Proposición de juego de Shunt para hidrocefalia**  
**Proposition à boîte pour Shunt hydrocéphalie**  
**Proposta di set per l'idrocefalo Shunt**

**PART 1**

Item number	Description	Quantity
<b>01.28.04</b>	Scalpel handle · no 4 · standard · 13.5 cm	2
<b>03.07.84</b>	Surgical scissors · delicate · curved · sharp / blunt · 14.5 cm	1
<b>04.35.14</b>	METZENBAUM-SLIM Scissors · curved · 14 cm	1
<b>04.35.68</b>	METZENBAUM-SLIM "HM" Scissors · curved · 18 cm	1
<b>04.67.14</b>	REYNOLDS (JAMESON) Scissors · curved · 14 cm	1
<b>06.07.16</b>	Tissue forceps · slim · 1 x 2 teeth · 16 cm	2
<b>06.46.18</b>	POTTS-SMITH Dressing forceps · serrated · 18 cm	2
<b>07.63.32</b>	MICRO 2000 Forceps · straight · blunt · 0.3 mm · 14 cm	2
<b>09.60.10</b>	REDON Guide needle · slight curved · knife tip · threaded end · 10 French	1
<b>09.82.30</b>	FRAZIER Suction cannula · 10 French · straight · 12.5 cm	1
<b>09.83.80</b>	FRAZIER (FERGUSSON) Suction cannula · 10 French · angled · 18 cm	1
<b>09.83.82</b>	FRAZIER (FERGUSSON) Suction cannula · 12 French · angled · 18 cm	1
<b>10.18.65</b>	MAYO-HEGAR "HM" Needle holder · 16 cm	1
<b>10.20.68</b>	CRILE-WOOD "HM" (DEBAKEY HM) Needle holder · 18 cm	1
<b>11.18.70</b>	MATHIEU-KOCHER "HM" Needle holder · 20 cm	1
<b>15.32.09</b>	HARTMANN (BABY MOSQUITO) Hemostatic forceps · straight · 10 cm	2
<b>15.45.12</b>	HALSTED-MOSQUITO Forceps · curved · 12.5 cm	5
<b>16.40.18</b>	HALSTED (ADSON) Hemostatic forceps · straight · 18 cm	2
<b>16.85.18</b>	MIKULICZ Peritoneum forceps · 18 cm	4
<b>17.06.14</b>	MIXTER BABY Forceps · 14 cm	1
<b>17.06.19</b>	MIXTER BABY Forceps · 19 cm	1
<b>19.16.20</b>	GROSS Dressing forceps · straight · 20 cm	2



**Siebvorschlag für Hydrocephalus Shunt**  
**Set Suggestion for Hydrocephalus Shunt**  
**Proposición de juego de Shunt para hidrocefalia**  
**Proposition à boîte pour Shunt hydrocéphalie**  
**Proposta di set per l'idrocefalo Shunt**

**C05**



**PART 2**

Item number	Description	Quantity
19.17.26	MAIER Dressing forceps · curved · 26 cm	4
19.19.25	PELKMANN Dressing forceps · curved · 25 cm	1
20.30.12	FRAZIER Dura and skin hook · 12.5 cm	1
20.64.03	Tracheal retractor · 3 teeth · sharp · 10 mm · 16 cm	2
22.16.13	ROUX-BABY Retractor · double-ended · 15 × 15 mm / 21 × 18 mm · figure 0 · 13 cm	2
23.15.01	SAUERBRUCH Retractor · 18 × 45 mm · 23 cm	1
24.04.07	FINSEN Retractor · sharp · 7 cm	1
24.22.11	WEITLANER Retractor · 2 × 3 teeth · blunt · 10.5 cm	1
24.30.13	WEITLANER-BECKMANN Retractor · sharp · 14.5 cm	1
24.30.14	WEITLANER-BECKMANN Retractor · blunt · 14.5 cm	1
26.54.10	LAMBOTTE Raspatory · 10 mm · 22 cm	1
29.52.42	SCHEDE Sharp curette · figure 2/0 · 17 cm	1
31.11.13	MARQUARDT Bone rongeur · curved · 20 cm	1
46.28.15	BUNT Instrument holder · 12 cm	1
55.39.20	Neonatal vascular clamp · medium · 12 cm	1
57.36.14	DAVIS Dissector · double-ended · 4 / 5 mm · 25 cm	1
57.39.06	CONE Ventricular needle · 1.2 × 90 mm	1
57.39.07	CONE Ventricular needle · 1.4 × 90 mm	1
67.15.35	YANKAUER Septum elevator · 6 mm · 18 cm	1
49.60.13	Medicontainer · silver · 590 × 290 × 135 mm	1
49.97.12	Wire basket · 480 × 255 × 50 mm	2

**C06**

**Siebvorschlag für Handinstrumente der peripheren Nerven**  
**Set Suggestion for Hand Instruments of the Peripheral Nerves**  
**Proposición de juego para instrumentos de manos de los nervios periféricos**  
**Proposition à boîte pour instruments à main des nerfs périphériques**  
**Proposta di set per strumenti della mano dei nervi periferici**

**PART 1**

Item number	Description	Quantity
<b>01.27.03</b>	Scalpel handle · no 3 · standard · 12.5 cm	2
<b>01.28.04</b>	Scalpel handle · no 4 · standard · 13.5 cm	1
<b>03.06.14</b>	Operating scissors · straight · sharp / blunt · 14.5 cm	1
<b>03.06.84</b>	Operating scissors · delicate · straight · sharp / blunt · 14.5 cm	1
<b>03.07.84</b>	Operating scissors · delicate · curved · sharp / blunt · 14.5 cm	1
<b>04.35.14</b>	METZENBAUM-SLIM Scissors · curved · 14 cm	1
<b>04.35.68</b>	METZENBAUM-SLIM "HM" Scissors · curved · 18 cm	1
<b>04.67.14</b>	REYNOLDS (JAMESON) Scissors · curved · 14 cm	1
<b>06.21.15</b>	ADSON Tissue forceps · smooth · 1 × 2 teeth · 15 cm	2
<b>06.22.15</b>	MICRO-ADSON Dressing forceps · serrated · 15 cm	2
<b>06.23.15</b>	MICRO-ADSON Tissue forceps · 1 × 2 teeth · 15 cm	2
<b>09.15.84</b>	Grooved director · curved · 14 cm	1
<b>09.60.10</b>	REDON Guide needle · slight curved · knife tip · threaded end · 10 French	1
<b>10.08.65</b>	CONVERSE "HM" Needle holder · 15 cm	1
<b>11.20.67</b>	MATHIEU "HM" Needle holder · 17 cm	1
<b>15.45.12</b>	HALSTED-MOSQUITO Forceps · curved · 12.5 cm	6
<b>16.11.16</b>	ROCHESTER-PEAN Hemostatic forceps · curved · 16 cm	2
<b>17.05.14</b>	ADSON-BABY Forceps · 14 cm	1
<b>17.55.10</b>	BACKHAUS Towel clamp · 10.5 cm	6



**Siebvorschlag für Handinstrumente der peripheren Nerven**  
**Set Suggestion for Hand Instruments of the Peripheral Nerves**  
**Proposición de juego para instrumentos de manos de los nervios periféricos**  
**Proposition à boîte pour instruments à main des nerfs périphériques**  
**Proposta di set per strumenti della mano dei nervi periferici**

**C06**



Item number	Description	Quantity
<b>19.16.20</b>	GROSS Dressing forceps · straight · 20 cm	3
<b>19.17.26</b>	MAIER Dressing forceps · curved · 26 cm	2
<b>19.19.25</b>	PELKMANN Dressing forceps · curved · 25 cm	1
<b>20.17.14</b>	CUSHING Vein hook · 14 mm · 20 cm	2
<b>20.64.04</b>	Tracheal retractor · 4 teeth · sharp · 14 mm · 16 cm	2
<b>20.65.03</b>	Tracheal retractor · 3 teeth · blunt · 10 mm · 16 cm	1
<b>20.65.04</b>	Tracheal retractor · 4 teeth · blunt · 14 mm · 16 cm	1
<b>24.05.57</b>	FINSEN Retractor with catch · sharp · 7 cm	1
<b>24.30.14</b>	WEITLANER-BECKMANN Retractor · blunt · 14.5 cm	1
<b>46.37.50</b>	Needle case · Ø 65 mm	1
<b>46.37.51</b>	Inner case only for 46.37.50	1
<b>49.50.10</b>	Medicontainer · silver · 290 × 290 × 100 mm	1
<b>49.97.01</b>	Wire basket · 240 × 255 × 30 mm	1
<b>49.97.02</b>	Wire basket · 240 × 255 × 50 mm	1
<b>49.97.72</b>	Silicon mat · distance between naps 3 mm · 240 × 220 mm	2

**PART 2**

**C07**

**Siebvorschlag für die transspheoidale Hypophysektomie**  
**Set Suggestion for Transspheoidal Hypophysectomy**  
**Proposición de juego para la hipofisectomía transesfenoidal**  
**Proposition à boîte pour l'hypophysectomie transsphénoïdale**  
**Proposta di set per l'ipofisectomia transfenoidale**

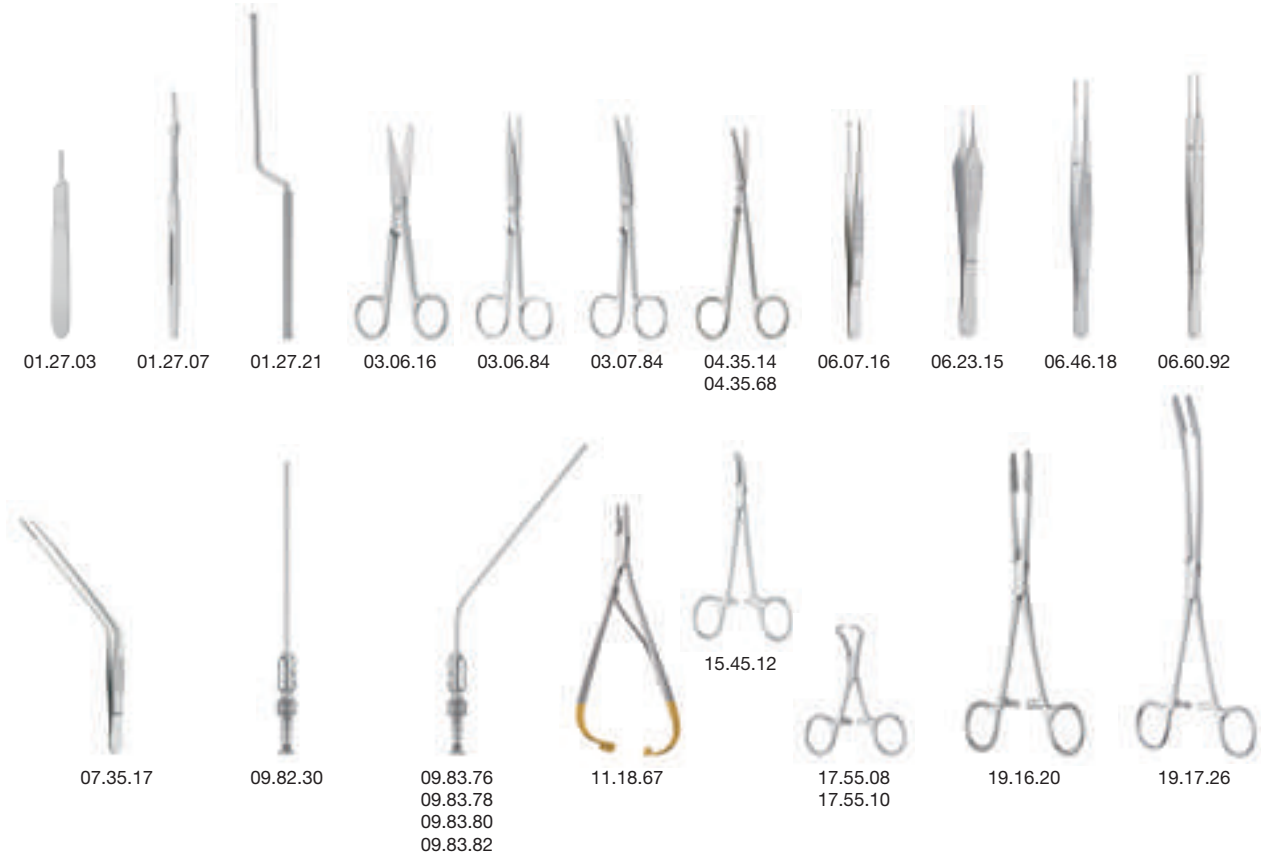
**PART 1**

Item number	Description	Quantity
01.27.03	Scalpel handle · no 3 · standard · 12.5 cm	2
01.27.07	Scalpel handle · no 7 · long · 16.5 cm	1
01.27.21	LANDOLT Scalpel handle · bayonet · 21 cm	1
03.06.16	Operating scissors · straight · sharp / blunt · 16.5 cm	1
03.06.84	Operating scissors · delicate · straight · sharp / blunt · 14.5 cm	1
03.07.84	Operating scissors · delicate · curved · sharp / blunt · 14.5 cm	1
04.35.14	METZENBAUM-SLIM Scissors · curved · 14 cm	1
04.35.68	METZENBAUM-SLIM "HM" Scissors · curved · 18 cm	2
06.07.16	Tissue forceps · slim · 1 × 2 teeth · 16 cm	2
06.23.15	MICRO-ADSON Tissue forceps · 1 × 2 teeth · 15 cm	1
06.46.18	POTTS-SMITH Dressing forceps · serrated · 18 cm	2
06.60.92	GERALD Tissue forceps · straight · 1 × 2 teeth · 18 cm	2
07.35.17	TROELTSCH Nasal forceps · serrated · 17 cm	1
09.82.30	FRAZIER Suction cannula · straight · 10 French · 12.5 cm	2
09.83.76	FRAZIER (FERGUSON) Suction cannula · angled · 6 French · 18 cm	1
09.83.78	FRAZIER (FERGUSON) Suction cannula · angled · 8 French · 18 cm	1
09.83.80	FRAZIER (FERGUSON) Suction cannula · angled · 10 French · 18 cm	1
09.83.82	FRAZIER (FERGUSON) Suction cannula · angled · 12 French · 18 cm	1
11.18.67	MATHIEU-KOCHER "HM" Needle holder · 17 cm	1
15.45.12	HALSTED-MOSQUITO Forceps · curved · 12.5 cm	5
17.55.08	BACKHAUS Towel clamp · 8.5 cm	5
17.55.10	BACKHAUS Towel clamp · 10.5 cm	5
19.16.20	GROSS Dressing forceps · straight · 20 cm	6
19.17.26	MAIER Dressing forceps · curved · 26 cm	2





**Siebvorschlag für die transssphenoidale Hypophysektomie**  
**Set Suggestion for Transssphenoidal Hypophysectomy**  
**Proposición de juego para la hipofisectomía transesfenoidal**  
**Proposition à boîte pour l'hypophysectomie transssphénoïdale**  
**Proposta di set per 'ipofisectomia transfenoidale**

**C07**

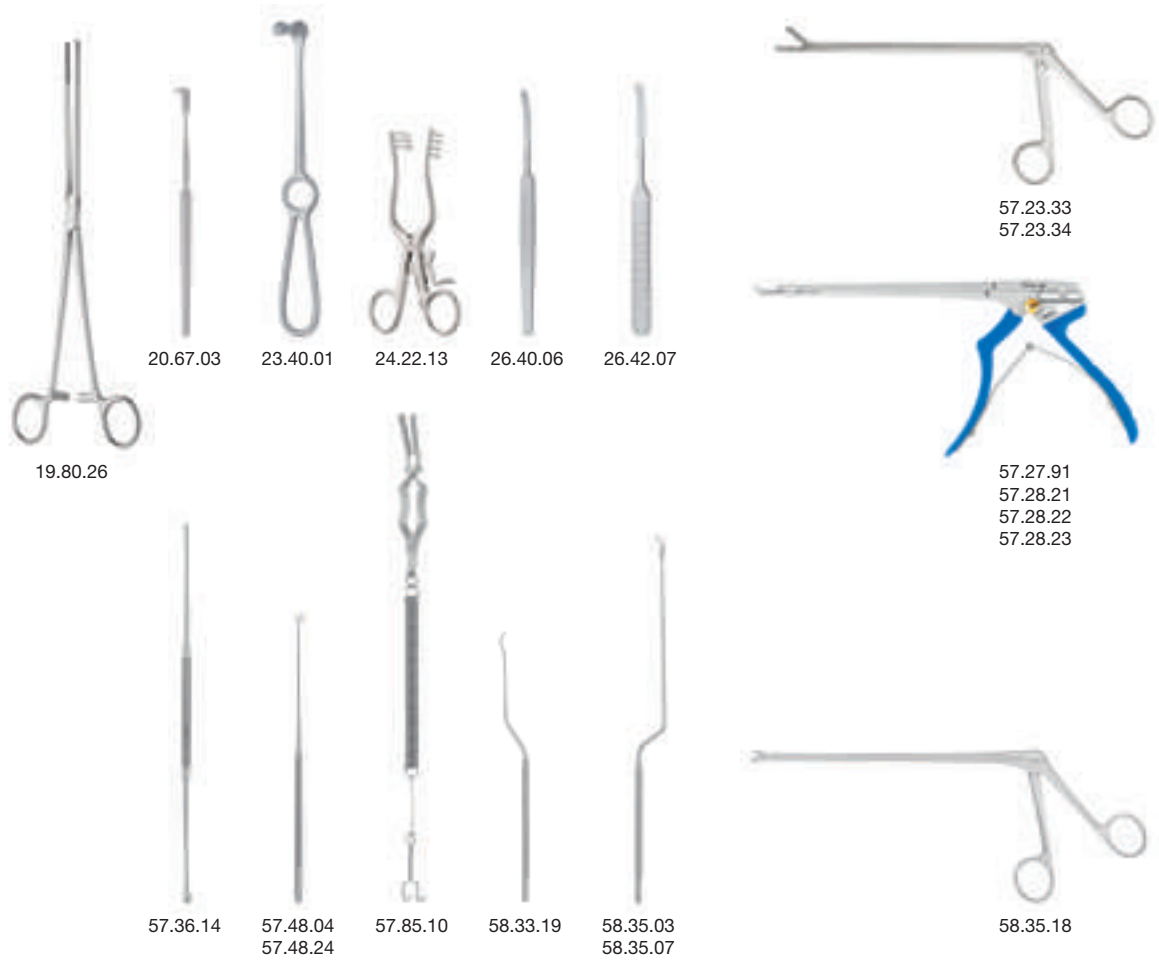

**PART 2**

Item number	Description	Quantity
19.80.26	BOZEMANN Dressing forceps · straight · 27 cm	1
20.67.03	Tracheal retractor · 3 teeth · blunt · 8 mm · 16 cm	2
23.40.01	KOCHER Retractor · 12 × 19 mm · 20 cm	2
24.22.13	WEITLANER Retractor · 3 × 4 teeth · sharp · 13 cm	1
26.40.06	KÖNIG Raspatory · 5 mm · 15 cm	1
26.42.07	WILLIGER Raspatory · 7 mm · 16 cm	1
57.23.33	CASPAR Rongeur · straight · 3 × 12 mm · 16 cm	1
57.23.34	CASPAR Rongeur · straight · 4 × 14 mm · 16 cm	1
57.27.91	KERRISON Rongeur · dismantable · angled upwards 40° · 1.5 mm · 18 cm	1
57.28.21	KERRISON Rongeur · dismantable · angled upwards 40° · 1 mm · 18 cm	1
57.28.22	KERRISON Rongeur · dismantable · angled upwards 40° · 2 mm · 18 cm	1
57.28.23	KERRISON Rongeur · dismantable · angled upwards 40° · 3 mm · 18 cm	1
57.36.14	DAVIS Dissector · double-ended · 4 mm / 5 mm · 25 cm	1
57.48.04	RAY Curette · 45° · Ø 4 mm · 19 cm	1
57.48.24	RAY Curette · 45° · offset · Ø 4 mm · 19 cm	1
57.85.10	YASARGIL Galea hook · 31 cm	15
58.33.19	YASARGIL Raspatory · curved down · 2 mm · 18.5 cm	1
58.35.03	HARDY Dissector · bayonet · left · 24 cm	1
58.35.07	HARDY Enucleator · bayonet · left · 24 cm	1
58.35.18	YASARGIL Forceps cup jaws · Ø 2.2 mm · 19 cm	1



**C07**

**Siebvorschlag für die transspheoidale Hypophysektomie**  
**Set Suggestion for Transspheoidal Hypophysectomy**  
**Proposición de juego para la hipofisectomía transesfenoidal**  
**Proposition à boîte pour l'hypophysectomie transsphénoïdale**  
**Proposta di set per ipofisectomia transfenoidale**

58.35.44  
58.35.4658.35.49  
58.35.50

58.35.90

58.35.92

58.35.99

58.36.20  
58.36.2558.36.26  
58.36.27

58.45.10

58.45.40

59.24.14

59.44.73  
59.44.75

62.23.25

66.08.07

67.02.35  
67.02.55  
67.02.75

49.60.22

49.97.12

**PART 3**

Item number	Description	Quantity
<b>58.35.44</b>	HARDY Curette · malleable · Ø 4 mm · 26 cm	1
<b>58.35.46</b>	HARDY Curette · malleable · Ø 6 mm · 26 cm	1
<b>58.35.49</b>	NICOLA Curette · malleable · bayonet · right side cutting · Ø 6.5 mm · 26 cm	1
<b>58.35.50</b>	NICOLA Curette · malleable · bayonet · Ø 6.5 mm · 26 cm	1
<b>58.35.90</b>	CUSHING-LANDOLT Specula · 90 mm	1
<b>58.35.92</b>	LANDOLT Hook · malleable · 26 cm	1
<b>58.35.99</b>	LANDOLT Spreader · 21 cm	1
<b>58.36.20</b>	LANDOLT-REULEN Dissector · 2 mm · 26 cm	1
<b>58.36.25</b>	LANDOLT-REULEN Curette · Ø 2.5 mm · 26 cm	1
<b>58.36.26</b>	FAHLBUSCH Spoon · malleable · Ø 2.5 mm · 26 cm	1
<b>58.36.27</b>	FAHLBUSCH Curette · malleable · Ø 2.5 mm · 26 cm	1
<b>58.45.10</b>	NICOLA Forceps cup jaws · Ø 2 mm · 18 cm	1
<b>58.45.40</b>	NICOLA Alligator type scissors · 18 cm	1
<b>59.24.14</b>	YASARGIL Micro Forceps · bayonet · blunt · 0.9 mm · 24 cm	1
<b>59.44.73</b>	YASARGIL Grasping forceps · Ø 3 mm · 22 cm	1
<b>59.44.75</b>	YASARGIL Grasping forceps · Ø 5 mm · 22 cm	1
<b>62.23.25</b>	Suction and irrigation tube · Ø 2.5 mm / Ø 2 mm	1
<b>66.08.07</b>	KILIAN Nasal speculum · figure 3 · 75 mm · 14 cm	1
<b>67.02.35</b>	COTTLE Nasal speculum · figure 1 · 35 mm · 14 cm	1
<b>67.02.55</b>	COTTLE Nasal speculum · figure 2 · 55 mm · 14 cm	1
<b>67.02.75</b>	COTTLE Nasal speculum · figure 3 · 75 mm · 14 cm	1
<b>49.60.22</b>	Medicontainer · silver · 590 × 290 × 220 mm	1
<b>49.97.12</b>	Wire basket · 480 × 255 × 50 mm	4



Alphabetischer und numerischer Index  
Alphabetical and Numerical Index  
Indice alfabético y numérico  
Index alphabétique et numérique  
Indice alfabetico e numerico

D

neuro  
**CRANIALIS**

**Alphabetischer und numerischer Index**  
**Alphabetical and Numerical Index**  
**Indice alfabético y numérico**  
**Index alphabétique et numérique**  
**Indice alfabetico e numerico**

<b>D01</b>	Alphabetischer Index	<b>DEUTSCH</b>	295
<b>D02</b>	Alphabetical index	<b>ENGLISH</b>	301
<b>D03</b>	Indice alfabético	<b>ESPAÑOL</b>	307
<b>D04</b>	Index alphabétique	<b>FRANÇAIS</b>	313
<b>D05</b>	Indice alfabetico	<b>ITALIANO</b>	319
<b>D06</b>	Numerischer Index Numerical index Indice numérico Index numérique Indice numerico		326



<b>A</b>	
ACLAND Approximatoren	97
ACLAND Anlegepinzetten	93, 97
ACLAND Mikro-Gefäßclips	93, 97
Adaptionsinstrument	248
ADSON-ANDERSON Wundspreizer	103
ADSON Bohrerführungszange	147
ADSON Elevatorium	107
ADSON Feine Pinzetten	32
ADSON Häkchen	172
ADSON HM Feine Pinzetten	32
ADSON JACOBSON Mikro-Pinzetten	40
ADSON MICRO Feine Pinzetten	32
ADSON Raspatorien	110
ADSON Wundspreizer	103
Anatomische Pinzetten	32-35
ANDERSON ADSON Wundspreizer	103
Anlege- und Entnahmezangen für Kopfhautklammern	140-141
Anlegepinzetten	92-97
Anlegezangen für Bulldog-Klemmen	87
Anlegezangen für Titan-Clips	91
Anlegezangen für zerebrovaskuläre Clips	221-228
Anschlusskabel bipolar	64
Antihaft-Pinzetten	57-61
Approximatoren	94-98
Arbeitsaufsätze	145, 271
Arterienklemmen	88
Atraumatische Bulldog-Klemmen	85, 87
Atraumatische Gefäßpinzetten	36-37
Atraumatische Pinzetten	36-39
AUSTIN Nahtpinzette	56
<b>B</b>	
BABY-CRILE-WOOD HM Nadelhalter	70
BABY-CRILE-WOOD Nadelhalter	69
BABY DANDY Arterienklemme	88
BABY-METZENBAUM Feine Präparierscheren	15
BACON Hohlmeißelzange	120
BAILEY DE MARTEL Einführungsinstrument	148
Bajonett-Saugkanüle	83
Bajonettpinzetten	47-53, 60-63
BARRAQUER Mikro-Nadelhalter	73
BAUMGARTNER HM Nadelhalter	67
BECKMANN WEITLANER Wundspreizer	104
BEYER Hohlmeißelzangen	119, 123
Biegezangen	247
BIEMER Approximatoren	94, 98
BIEMER Anlegepinzetten	94-96
BIEMER Ersatzschlüssel	98
BIEMER Mikro-Gefäßclips	94
BIEMER Mikroschere	23
BIEMER-MÜLLER Approximatoren	95-96

BIER Punktionskanülen	81
Bipolare Anschlusskabel	64
Bipolare Antihaft-Pinzetten	57-61
Bipolare Pinzetten	57-63
Bohrer	150-151, 272-274
Bohrerführungszange	147
Bohrlochabdeckplatten	235, 243
Bohrlochtiefenlehre	248
Bulldog-Klemmen	85-87
Bulldog-Klemmen atraumatisch	85, 87
Bulldog-Klemmen Titan	85
<b>C</b>	
CASPAR Dissektoren	183-184
CASPAR Explorationshäkchen	176
CASPAR PAPAVERO Spekula	264
CASPAR Raspatorien	108
CASTROVIEJO HM Mikro-Nadelhalter	72-73
CASTROVIEJO-MICRO Mikro-Nadelhalter	73
CASTROVIEJO Mikro-Nadelhalter	72
Chirurgische Pinzetten	32-35
Chirurgische Scheren	10-13
CLINIC LAHEY Hauthäkchen	173
Clips Titan	90
COBB Raspatorien	116
CONE Schädelstanzen	146
Container aus Aluminium	249
CONTOUR Wundspreizer	103
CRILE Häkchen	172
CRILE-WOOD HM (DEBAKEY HM) Nadelhalter	69
CRILE-WOOD Nadelhalter	69
CRILE-WOOD BABY HM Nadelhalter	70
CRILE-WOOD BABY Nadelhalter	69
CRUTCHFIELD Schädelhalter	149
CRUTCHFIELD Vorbohrer	151
CUSHING Flachbohrer	150
CUSHING HM Pinzetten anatomisch/chirurgisch	35
CUSHING-LANDOLT Spekula	263
CUSHING Nervhäkchen	167
CUSHING Pinzetten anatomisch/chirurgisch	35
CUSHING Raspatorien	112
CUSHING (TAYLOR) Bajonettpinzetten	51
CUSHING (TAYLOR) HM Bajonettpinzette	51
<b>D</b>	
DAHLGREN Schädelstanze	146
DANDY Arterienklemmen	88
DANDY-BABY Arterienklemme	88
DAVIS Dissektor	177
DAVIS Hirnspatel	200
DAVIS Separator	175
DEBAKEY AT Atraumatische Gefäßpinzetten	36-37
DEBAKEY AT Atraumatische Pinzetten	38-39

**Alphabetischer Index**

Alphabetical Index

Índice alfabético

Index alphabétique

Índice alfabético

**D01**

DEBAKEY AT Bulldogklemmen	87
DEBAKEY HM Nadelhalter	69
DE MARTEL (BAILEY) Einführungsinstrument	148
DENNIS Mikro-Pinzetten	45
Dermabrasionsfräser	274
D'ERRICO Perforationsbohrer	150
DEVILBISS Schädelstanze	146
Diamant-Kugelfräser	272
Diamant-Walzenfräser	272
Diamantmesser	185-187
DIEFFENBACH Bulldogklemmen	86
DIETHRICH Bulldogklemmen	86
DIETHRICH HEGEMANN Gefäßscheren	19
Dilatatoren Gefäß	189
Dissektoren	177-184, 255, 261
Dissektoren Dura	177
Doppelcontainer	276
Draht- und Mesh-Plattenscheren	30, 246
Draht- und Plattenschneidezangen	246
Drahtsägen	148
Druckluftmotoren	144, 269-270
Dura-Dissektoren	177
Dura-Separatoren	174-175
Durahäkchen	172-173
Duraschere	29
<b>E</b>	
ECHLIN Hohlmeißelzangen	127
EIF Haken	169
Einführungsinstrumente	148
Elevatorien	106-107
Entnahmezangen	87
Entnahmezangen für Kopfhautklammern	140-141
Entnahmezangen für zerebrovaskuläre Clips	229
Enukleatoren	256, 262
Explorationshäkchen	176
<b>F</b>	
Fadenführer	196
Fadengabel	196
FARABEUF Raspatorien	110
Fasspinzetten	53
Fasszange	260
Feine Pinzetten, anatomisch und chirurgisch	32-33
Feine Präparierscheren	14-15
Feine Scheren	10, 14-15
Feine Wundhaken	100
FERGUSSON FRAZIER Sauginstrumente	82
FERRIS-SMITH KERRISON Stanzen	164
FISCH Häkchen	170
FIXIT Kopfhalterungssystem	131-138
Flachbohrer	150
Fräser	150-151, 272-274
Fräser "Flamshape"	273

FRAZIER Dura- und Hauthäkchen	173
FRAZIER (FERGUSSON) Sauginstrumente	82
FRAZIER Sauginstrumente	81-82
FRAZIER Separatoren	174
FREER Elevatorien	107
FREER Raspatorien	108
FRIEDMAN Hohlmeißelzangen	119
Fußpedal	275
<b>G</b>	
Galeahaken	142
GALT Schädeltrephinen	147
Gefäßclips	89-98
Gefäßdilatatoren	189
Gefäßhäkchen	169
Gefäßmesser	192-193
Gefäßpinzetten atraumatisch	36-37
Gefäßscheren	19-20
Gewebekrallen	195
GIGLI Handgriffe	148
GIGLI (OLIVECRONA) Drahtsägen	148
GILLIES Chirurgische Pinzette	34
GILLIES Häkchen	173
GREENBERG PAR Feine Präparierscheren	14
GRUENWALD Bajonettpinzetten	51
<b>H</b>	
Häkchen	170-171, 255
Häkchen Dura	172-173
Häkchen Exploration	176
Häkchen Gefäß	169
Häkchen Haut	172-173
Häkchen Nerv	166-169
Haken	166-176
Haken Galea	142
Haken Sympathektomie	176
Haken Wund	100
HALSEY HM Nadelhalter	67
Halteklammer	64
Haltepinzetten	247
Handbohrapparate	150-152
Handgriffe	148
HARDY Dissektoren	261
HARDY Enukleatoren	262
HARDY Implantationsgabel	262
HARDY Küretten	253
HARTMANN PAPAVERO Spreizer für Spekula	264
Hauthäkchen	172-173
HEGAR MAYO HM Nadelhalter	68
HEGEMANN-DIETHRICH Gefäßscheren	19
Hirnspatel	200-201
Hirnspatelhalter	202-206
HM Draht- und Mesh-Plattenscheren	246



HM Draht- und Plattenschneidezangen	246
HM Ligaturscheren	30
HM Pinzetten	32, 35, 52
HOEN Elevatorien	106
HOEN Kopfhautklemme	88
HOEN Separatoren	174
Hohlmeißelzangen	119-127
HOPKINS JOHNS	
Anlege- und Entnahmezange	87
HOPKINS JOHNS Bulldogklemmen	87
HORSLEY Separator	175
HUDSON Handbohrapparat	150
HUNT Fasspinzetten	52
<b>I</b>	
Implantationsgabel	262
Instrumente für Trepanation und Kraniotomie	143-152
Instrumentenkassette	187
<b>J</b>	
JACOBSON-ADSON Mikro-Pinzetten	40
JACOBSON Fadengabel	196
JACOBSON Gefäßmesser	192
JACOBSON Häkchen	170
JACOBSON HM Mikro-Nadelhalter	74
JACOBSON Knopfsonde	189
JACOBSON Mikro-Nadelhalter	74
JACOBSON Mikro-Pinzetten	43
JACOBSON Mikro-Schere	24
JAMESON REYNOLDS Präparierscheren	18
JANSEN ZAUFAL Hohlmeißelzange	123
JOHNS-HOPKINS	
Anlege- und Entnahmezangen	87
JOHNS-HOPKINS Bulldogklemmen	87
JULIAN HM Nadelhalter	70
JULIAN Nadelhalter	70
Juwelierpinzetten	39, 58-59
<b>K</b>	
Kanülen Punktion	81
Kanülen Saug	80, 82-83
Kassette für Neurofixation	248
Kassetten für zerebrovaskuläre Clips	230-232
KERRISON "DieBlauen" Stanzen	153-157
KERRISON (FERRIS-SMITH) Stanzen	164
KERRISON (MICRO) Stanzen	160-163
KERRISON (SCHLESINGER) Stanzen	159
KERRISON (SPURLING) Stanzen	158
KERRISON Zerlegbare Stanzen	155-157
KEY Raspatorien	111
KEY LISTON Knochensplitterzange	127
KILLIAN Septum-Elevatorium	107
KLEINERT-KUTZ Hohlmeißelzangen	119
Klammern Kopfhaut	139-142
Klemmen Arterie	88

Klemmen Bulldog	85-87
Klemmen Kopfhaut	88
Klemmen Schädel	134-137
KLIMA-ROSEGGER Punktionskanüle	81
Knochensplitterzangen	127-128
Knopfsonden	189
KOCHER MATHIEU HM Nadelhalter	71
KOOS Gefäßmesser	193
Kopfhalterungssysteme	131-138
Kopfhautklammern	139-142
Kopfhautklemmen	88
Kopfhautspreizer	103
KRÄMER Raspatorien	109
Kraniotome	145
Kraniotomfräser	145
KRAYENBÜHL Häkchen	169
Kugelfräser	150, 272
Küretten	198, 252-254
KUTZ KLEINERT Hohlmeißelzangen	119
<b>L</b>	
LAHEY CLINIC Hauthäkchen	173
LAMBOTTE Raspatorien	111
Lamina-Meißel	257
LANDOLT CUSHING Spekula	263
LANDOLT E nukleatoren	256
LANDOLT Häkchen	255
LANDOLT Kürette	254
LANDOLT Löffel	254
LANDOLT Skalpellgriffe	6
LANDOLT Spreizzange für Spekula	263
LANDOLT-REULEN Dissektor	255
LANDOLT-REULEN Häkchen	255
LANDOLT-REULEN Raspatorium	256
LANDOLT Tumorfasszange	257
LANGENBECK Elevatorien	106
LANGENBECK HM Nadelhalter	72
LANGENBECK Raspatorium	112
Lanzettenmesser	195
LEKSELL Hohlmeißelzangen	125-126
LEMPERT Hohlmeißelzangen	120
LEYLA Flexibler Spannarm	204
LEYLA Hirnspatelhalter	202-203
Ligaturscheren	30
LISTON-KEY Knochensplitterzange	127
LISTON LITTAUER Knochensplitterzange	128
LISTON RUSKIN Knochensplitterzangen	128
LITTAUER-LISTON Knochensplitterzange	128
Löffel	254
Löffel scharf	197-198
Löffelzangen	258, 259
LUCAE Nervhäkchen	166
LUER Hohlmeißelzangen	120

**Alphabetischer Index**

Alphabetical Index

Índice alfabético

Index alphabétique

Índice alfabético

**D01**

LUER STILLE Hohlmeißelzangen	124
<b>M</b>	
MARQUARDT Hohlmeißelzange	123
MASEL Bohrlochabdeckplatten	243
MATHIEU HM Nadelhalter	71
MATHIEU-KOCHER HM Nadelhalter	71
MATHIEU Nadelhalter	71
MAYO Chirurgische Scheren	13
MAYO-HEGAR HM Nadelhalter	68
MCINDOE Anatomische Pinzetten	34
MCINDOE Knochensplitterzangen	128
MCKENZIE Perforationsbohrer	150
Medicontainer	249
MEHDORN Anlegepinzette	92
MEHDORN Mikro-Gefäßclips	92
Meißel für die Lamina	257
Mesh-Plattenscheren	30, 246
Messer Diamant	185-187
Messer Gefäß	192-193
Messer Lanzette	195
Messer Tumor	194
METZENBAUM Präparierscheren	16
METZENBAUM BABY Feine Präparierscheren	15
METZENBAUM-SLIM Präparierscheren	17
MICHELE Schädeltrephinen	147
MICRO 2000 Nadelhalter	76, 78
MICRO 2000 Nahtpinzetten	54-56
MICRO 2000 Pinzetten	40-42, 48, 54-56
MICRO 2000 Scheren	21, 26
MICRO-ADSON Feine Pinzetten	32
MICRO CASTROVIEJO Mikro-Nadelhalter	73
MICRO KERRISON Stanzen	160-163
Mikro-Fadenführer	196
Mikro-Fadengabel	196
Mikro-Gefäßclips	92-98
Mikro-Gefäßdilatoren	189
Mikro-Gefäßmesser	192-193
Mikro-Gewebekrallen	195
Mikro-Häkchen	174
Mikro-Instrumente	189-198
Mikro-Knopfsonden	189
Mikro-Küretten	198
Mikro-Lanzettenmesser	195
Mikro-Löffel	197-198
Mikro-Löffelzangen	259
Mikro-Nadelhalter	72-78
Mikro-Nadelhalter Titan	77
Mikro-Nadel	197
Mikro-Pinzetten	30-50
Mikro-Pinzetten Titan	44, 46
Mikro-Raspatorien	191-192
Mikro-Tumormesser	194

Mikro-Scheren	20-28, 260
Mikro-Scheren MICRO 2000	21, 26
MILLESi Mikro-Schere	24
MINI RUSKIN Hohlmeißelzangen	121
MINI-RYDER HM Nadelhalter	70
MISKIMON Wundspreizer	102
MOD. AACHEN Hirnspatel	201
MOD. KÖLN Kopfhautklammer	142
Motor mit INTRA-Kupplung	269
Motorschlauch	275
Motorschmiermittel	276
MÜHLING Raspatorien	108
MÜLLER BIEMER Approximatoren	95-96
<b>N</b>	
Nadel	197
Nadelhalter	65-78
Nadelhalter MICRO 2000	76, 78
Nadelhalter Mikro	72-78
Nadelhalter Titan	77
Nahtpinzetten	54-56
NEIVERT HM Nadelhalter	67
Nerv-Separatoren	174-175
Nervhäkchen	166-169
Neurofräser	273
Neuro-Fixationssystem	233-249
NICOLA Küretten	253-254
NICOLA Löffelzange	258
NICOLA Micro-Schere	260
<b>O</b>	
OLIVECRONA Dissektoren	177
OLIVECRONA GIGLI Drahtsägen	148
OLIVECRONA Hirnspatel	201
OLIVECRONA Raspatorium	110
OLIVECRONA Trigeminiusschere	29
<b>P</b>	
PAPAVERO-CASPAR Spekula	264
PAPAVERO-HARTMANN Spreizer für Spekula	264
PAPAVERO Lamina-Meißel	257
PEN Saugkanülen	79-80
PENFIELD Dissektoren	178-179
Perforationsbohrer	150
PETERSEN SMITH Hohlmeißelzangen	122
Pinzetten	31-63
Pinzetten anatomisch/chirurgisch	32-35
Pinzetten antihaft	57-61
Pinzetten atraumatisch	36-39
Pinzetten bajonettförmig	47-53, 60-63
Pinzetten bipolar	57-63
Pinzetten bipolar antihaft	57-61
Pinzetten chirurgisch	32-35
Pinzetten fass	52-53
Pinzetten fein	32-33





**Alphabetischer Index**  
**Alphabetical Index**  
**Indice alfabético**  
**Index alphabétique**  
**Indice alfabético**

**D01**

**DEUTSCH**

Pinzetten Gefäß	36-37
Pinzetten HM	32, 35, 52
Pinzetten Juwelier	39, 58-59
Pinzetten Mikro	39-50
Pinzetten MICRO 2000	40-42, 48, 54-56
Pinzetten Mikro Titan	44, 46
Pinzetten Plattenhalter	247
Pinzetten Schraubenhalter	247
Plattenbiegeezangen	247
Plattenhaltepinzetten	247
Plattenscheidezangen	246
Plattenschere	30
POTTS-SMITH Gefäßscheren	19-20
POTTS-SMITH Pinzetten anatomisch/chirurgisch	34
POTTS-YASARGIL Mikro-Schere	24
Präparierscheren	14-18
Punktionskanülen	81
<b>Q</b>	
QUINCKE Punktionskanülen	81
<b>R</b>	
RAIMONDI Kopfhautklemme	88
RALK Handbohrapparat	152
RANEY Kopfhautklammern	140-141
Raspatorien	108-117, 190-192, 256
RAY Küretten	252
Reinigungs-Tray	276
REULEN LANDOLT Dissektor	255
REULEN LANDOLT Häkchen	255
REULEN LANDOLT Raspatorien	256
REYNOLDS (JAMESON) Präparierscheren	18
RHOTON Dissektoren	182
RHOTON Häkchen	171
RHOTON Knopfsonde	189
RHOTON Nadel	197
RHOTON Raspatorium	191
RHOTON Scharfe Löffel	197
RIECHERT Fixiervorrichtungen	204
RIECHERT Halter für flache Hirnspatel	204
ROSEGGER KLIMA Punktionskanüle	81
Rosenbohrer	272
RUSKIN Hohlmeißelzangen	121-122
RUSKIN-LISTON Knochensplitterzangen	128
RUSKIN-MINI Hohlmeißelzangen	121
RYDER MINI HM Nadelhalter	70
<b>S</b>	
SACHS Separator	175
SAMII Lanzettenmesser	195
SAMII Tumormesser	194
Saug- und Spülinstrumente	80-83
Saugkanülen	80, 82-83
Schädelhalter	149

Schädelklemmen	134-137
Schädelstanzen	146
Schädeltrephinen	147
Scharfe Löffel	197-198
Scheren	7-30
Scheren chirurgisch	10-13
Scheren Draht	30, 246
Scheren Dura	29
Scheren fein	10, 14-15
Scheren Gefäß	19-20
Scheren Ligatur	30
Scheren Mesh-Platten	30, 246
Scheren MICRO 2000	21, 26
Scheren Mikro	20-28, 260
Scheren Präparier	14-18
Scheren Trigeminus	29
Scheren Tumor	22
SCHLESINGER KERRISON Stanzen	159
SCHMIEDEN (TAYLOR) Duraschere	29
Schraubendrehergriffe	241, 245, 250
Schraubendreherklingen	241, 245, 250
Schraubenthaltepinzette	247
SEDILLOT Raspatorien	109
SELECT Feine Pinzetten	33
SEMB-STILLE Hohlmeißelzangen	124
SEMKEN Feine Pinzetten	33
Separatoren	174-175
Septum-Elevatorien	107
SHEA Feine Präparierscheren	14
SHERMAN STILLE Handbohrapparat	151
Siebkorp	249
Skalpelle	3-6
Skalpellgriffe	4-6
Skalpelloklingen	4-6
SLIM METZENBAUM Präparierscheren	17
SLIM Feine Präparierscheren	15
SMITH FERRIS KERRISON Stanzen	164
SMITH POTTS Gefäßscheren	19-20
SMITH POTTS Pinzetten anatomisch/chirurgisch	34
SMITH-PETERSEN Hohlmeißelzangen	122
SMITHWICK Sympathektomie-Haken	176
SÖRENSEN Schädelklemmen	134-137
Spekula	263-264
Spekula-Spreizzange	263
Spreizer für Spekula	264
Spreizer Wund	101-104
Spiralbohrer	151-152, 241, 245, 250, 274
Spritzschutz für die Dermabrasion	274
Sprühadapter	276
Spülinstrumente	80-83
Spülrohre	271

**Alphabetischer Index**

Alphabetical Index

Índice alfabético

Index alphabétique

Índice alfabético

**D01****DEUTSCH**

SPURLING KERRISON Stanzen	158
Stanzen	153-164
Stanzen Schädel	146
STELLBRINK Hohlmeißelzangen	119
Sterilgut-Container	249
STILLE Handbohrapparat	151
STILLE Hohlmeißelzange	126
STILLE-LUER Hohlmeißelzangen	124
STILLE-SHERMAN Handbohrapparat	151
STILLE SEMB Hohlmeißelzangen	124
STRAIGHT Hauthäkchen	173
STRULLY Trigeminesschere	29
Sympathektomie-Haken	176
<b>T</b>	
TAYLOR CUSHING Bajonettpinzetten	51
TAYLOR CUSHING HM Bajonettpinzette	51
TAYLOR SCHMIEDEN Duraschere	29
Tiefenlehre	248
Titan Mikro-Nadelhalter	77
Titan Mikro-Pinzetten	44, 46
Titan Bulldog-Klemmen	85
Titan-Clips	90
Titan-Platten	234-239, 242-243, 250
Titan-Schrauben	240, 244, 250
TOENNIS Dissektoren	180
TOENNIS Häkchen	174
TOENNIS HM Nadelhalter	72
TOENNIS Tumorfasszangen	53
Tray für Reinigung	276
Trepanfräser	145
Trepanmotor	144
Trephinen	151
Trigeminesscheren	29
Tropfen-Saugkanülen	83
Tumorfasszangen	53, 257
Tumormesser	194
Tumorscheren	22
TUOHY Punktionskanülen	81
<b>U</b>	
UNIVERSAL Draht- und Mesh-Plattenschere	30
UNIVERSAL HM Draht- und Mesh-Plattenschere	30, 246
<b>V</b>	
VIPAIR Druckluftmotorensystem	143-145, 265-276
<b>W</b>	
WAGNER Raspatorien	117
Walzenfräser	273
Wandschläuche	275
WEITLANER Wundspreizer	101-102
WEITLANER-BECKMANN Wundspreizer	104

Werkzeugkassette	276
WILLIGER Raspatorien	108
Winkelmotor	144, 270
Wirbelkörperfräser	273
WOOD CRILE BABY HM Nadelhalter	70
WOOD CRILE BABY Nadelhalter	69
WOOD CRILE HM (DEBAKEY HM) Nadelhalter	69
WOOD CRILE Nadelhalter	69
Wundhaken	100
Wundspreizer	101-104
<b>Y</b>	
YASARGIL Anlegezangen für zerebrovaskuläre Clips	221-228
YASARGIL Dissektor	181
YASARGIL Entnahmezangen für zerebrovaskuläre Clips	229
YASARGIL Fadenführer	196
YASARGIL Fasspinzetten	53
YASARGIL Fasszange	260
YASARGIL Galeahaken	142
YASARGIL Gefäßmesser	193
YASARGIL Gewebekrallen	195
YASARGIL Löffelzangen	258
YASARGIL Mikro-Nadelhalter	74, 78
YASARGIL Mikro-Pinzetten	47, 49-50
YASARGIL Mikro-Scheren	24, 26-28
YASARGIL POTTS Mikro-Schere	24
YASARGIL Raspatorien	190-192
YASARGIL Saugrohre	82
YASARGIL Zerebrovaskuläre Clips	207-220
YASARGIL Zerebrovaskuläre Clips "Mini"	219-220
YASARGIL Zerebrovaskuläre Clips "Standard"	209-218
<b>Z</b>	
Zange Bohrerführung	147
Zange Fass	260
Zange Spreiz	263
Zangen Drahtschneide	246
Zangen Hohlmeißel	119-127
Zangen Knochensplitter	127-128
Zangen Plattenbiege	247
Zangen Plattenschneide	246
Zangen Tumor	53, 257
ZAUFAL-JANSEN Hohlmeißelzange	123
Zementbohrer	273
Zerebrovaskuläre Clips	207-220
Zerebrovaskuläre Clips "Mini"	219-220
Zerebrovaskuläre Clips "Standard"	209-218
Zerlegbare Stanzen	155-157



<b>A</b>	
ACLAND Approximators	97
ACLAND Applying forceps	93, 97
ACLAND Micro vessel clips	93, 97
ADSON-ANDERSON Self-retaining retractor	103
ADSON Delicate forceps	32
ADSON Drill guide forceps	147
ADSON Elevator	107
ADSON HM Delicate forceps	32
ADSON Hooks	172
ADSON JACOBSON Micro forceps	40
ADSON MICRO Delicate forceps	32
ADSON Raspatories	110
ADSON Self-retaining retractors	103
Aluminium container	249
ANDERSON ADSON Self-retaining retractor	103
Angled motor	144, 270
Applying and removing forceps for scalp clips	140-141
Applying forceps	92-97
Applying forceps for Bulldog clamps	87
Applying forceps for cerebrovascular clips	221-228
Applying forceps for titanium clips	91
Applying instrument	248
Approximators	94-98
Aspirating and irrigating instruments	79-83
Atraumatic Bulldog clamps	85, 87
Atraumatic vascular forceps	36-37
AUSTIN Suturing forceps	56
<b>B</b>	
BABY DANDY Hemostatic forceps	88
BABY-CRILE-WOOD HM Needle holder	70
BABY-CRILE-WOOD Needle holder	69
BABY-METZENBAUM Delicate dissecting scissors	15
BACON Bone rongeur	120
BAILEY DE MARTEL Guiding instrument	148
BARRAQUER Micro needle holders	73
BAUMGARTNER HM Needle holder	67
Bayonet forceps	47-53, 60-63
Bayonet suction cannula	83
BECKMANN WEITLANER Self-retaining retractors	104
Bending pliers	247
BEYER Bone rongeurs	119, 123
BIEMER Approximators	94, 98
BIEMER Applying forceps	94-96
BIEMER Micro scissors	23
BIEMER Micro vessel clips	94
BIEMER-MÜLLER Approximators	95-96
BIEMER Replacement wrench	98
BIER Puncture cannulas	81

Bipolar connecting cables	64
Bipolar forceps	58-63
Bipolar non-stick forceps	57-61
Bone cutting forceps	127-128
Bone rongeurs	119-127
Bracket	64
Brain spatula retractors	202-206
Brain spatulas	200-201
Bulldog clamps	85-87
Bulldog clamps atraumatic	85, 87
Bulldog clamps titanium	85
Burr hole plates	235, 243
Burrs	150-151, 272-274
Burrs "Flameshape"	273
Burrs for dermabrasion	274
Button probes	189
<b>C</b>	
Cannulas puncture	81
Cannulas suction	80, 82-83
CASPAR Dissectors	183-184
CASPAR Exploration hooks	176
CASPAR PAPAVERO Specula	264
CASPAR Raspatories	108
CASTROVIEJO HM Micro needle holders	72-73
CASTROVIEJO Micro needle holders	72
CASTROVIEJO-MICRO Micro needle holders	73
Cement drills	273
Cerebrovascular clips	207-220
Cerebrovascular clips "Mini"	219-220
Cerebrovascular clips "Standard"	209-218
Chisel for lamina	257
Clamps	85-88
Clamps atraumatic	85, 87
Clamps Bulldog	85-87
Cleaning tray	276
CLINIC LAHEY Skin hook	173
Clips scalp	139-142
COBB Raspatories	116
CONE Skull punch	146
Connecting cables bipolar	64
Container for sterilization	249
CONTOUR Self-retaining retractor	103
Craniotomes	145
Craniotome burrs	145
CRILE Hook	172
CRILE-WOOD HM (DEBAKEY HM) Needle holders	69
CRILE-WOOD Needle holders	69
CRILE-WOOD BABY HM Needle holder	70
CRILE-WOOD BABY Needle holder	69
CRUTCHFIELD Reamer	151



**Alphabetischer Index**  
**Alphabetical Index**  
**Índice alfabético**  
**Index alphabétique**  
**Índice alfabético**

D02

ENGLISH

CRUTCHFIELD Skull traction tongs	149
Curettes	252-254
Curettes sharp	197-198
CUSHING Flat drills	150
CUSHING Forceps, dressing/tissue	35
CUSHING HM Forceps, dressing/tissue	35
CUSHING-LANDOLT Specula	263
CUSHING Nerve hooks	167
CUSHING Raspatories	112
CUSHING (TAYLOR) Bayonet forceps	51
CUSHING (TAYLOR) HM Bayonet forceps	51
Cutting burrs, barrel style	273
<b>D</b>	
DAHLGREN Skull punch	146
DANDY-BABY Hemostatic forceps	88
DANDY Hemostatic forceps	88
DAVIS Brain spatulas	200
DAVIS Dissector	177
DAVIS Separator	175
DEBAKEY AT Atraumatic forceps	38-39
DEBAKEY AT Atraumatic vascular forceps	36-37
DEBAKEY AT Bulldog clamps	87
DEBAKEY HM Needle holders	69
Delicate forceps, dressing and tissue	32-33
Delicate retractors	100
Delicate scissors	10, 14-15
DE MARTEL (BAILEY) Guiding instrument	148
DENNIS Micro forceps	45
Depth gauge for drill-holes	248
D'ERRICO Perforator	150
DEVILBISS Skull punch	146
Diamond cutting burrs, barrel style	272
Diamond dust burrs	272
Diamond knives	185-187
DIEFFENBACH Bulldog clamps	86
DIETHRICH Bulldog clamps	86
DIETHRICH HEGEMANN Vascular scissors	19
Dilators vessel	189
Dismantable rongeurs	155-157
Dissecting scissors	14-18
Dissectors	177-184, 255, 261
Dissectors dura	177
Double container	276
Drill guide forceps	147
Drills	150-151, 272-274
Drop-shape design suction cannulas	83
Dura dissectors	177
Dura hooks	172-173
Dura scissors	29
Dura separators	174-175
Dust burrs	150

<b>E</b>	
ECHLIN Bone rongeurs	127
EIF Hooks	169
Elevators	106-107
Enucleators	256, 262
Exploration hooks	176
<b>F</b>	
FARABEUF Raspatories	110
FERGUSON FRAZIER Aspirating instruments	82
FERRIS-SMITH KERRISON Rongeurs	164
FISCH Hook	170
FIXIT Head rest system	131-138
Flat drill	150
Foot switch	275
Forceps	31-63
Forceps atraumatic	36-39
Forceps bayonet	47-53, 60-63
Forceps bipolar	58-63
Forceps bipolar non-stick	57-61
Forceps bone cutting	127-128
Forceps cup jaws	258-259
Forceps delicate	32-33
Forceps dressing/tissue	32-35
Forceps drill guide	147
Forceps grasping	53, 257, 260
Forceps HM	32, 35, 52
Forceps jeweler's	39, 58-59
Forceps micro	39-50
Forceps micro titanium	44, 46
Forceps MICRO 2000	40-42, 48, 54-56
Forceps non-stick	57-61
Forceps plate holding	247
Forceps screw holding	247
Forceps spreading	263
Forceps suturing	54-56
Forceps tumor	53, 257
Forceps vascular	36-37
FRAZIER Aspirating instruments	81-82
FRAZIER Dura and skin hook	173
FRAZIER (FERGUSON) Aspirating instruments	82
FRAZIER Separator	174
FREER Elevators	107
FREER Raspatory	108
FRIEDMANN Bone rongeur	119
<b>G</b>	
Galea hooks	142
GALT Skull trephines	147
GIGLI (OLIVECRONA) Wire saws	148
GIGLI Handles	148
GILLIES Hooks	173
GILLIES Tissue forceps	34



Grasping forceps	53, 257, 260
GREENBERG PAR	
Delicate dissecting scissors	14
GRUENWALD Bayonet forceps	51
Guiding instruments	148
<b>H</b>	
HALSEY HM Needle holder	67
Hand drills	150-152
Hand pieces	145, 271
Handles	148
HARDY Curettes	253
HARDY Dissectors	261
HARDY Enucleators	262
HARDY Implant fork	262
HARTMANN PAPAVERO	
Spreader for specula	264
Head rest systems	131-138
Head rests	134-137
HEGAR MAYO HM Needle holders	68
HEGEMANN-DIETHRICH Vascular scissors	19
Hemostatic forceps	88
HM Forceps	32, 35, 52
HM Ligature scissors	30
HM Wire and Mesh plate cutting scissors	246
HM Wire and plate cutting pliers	246
HOEN Elevators	106
HOEN Scalp forceps	88
HOEN Separators	174
Hook sympathectomy	176
Hooks	166-176, 255
Hooks dura	172-173
Hooks exploration	176
Hooks galea	142
Hooks nerv	166-169
Hooks skin	172-173
Hooks vessel	169
HOPKINS JOHNS	
Applying and removing forceps	87
HOPKINS JOHNS Bulldog clamps	87
HORSLEY Separator	175
HUDSON Hand drill	150
HUNT Tumor grasping forceps	52
<b>I</b>	
Implant fork	262
Instrument tray	187
Instruments for the	
Trepanation and craniotomy	143-152
Irrigating instruments	80-83
Irrigation tubes	271
<b>J</b>	
JACOBSON-ADSON Micro forceps	40
JACOBSON Button probe	189

JACOBSON HM Micro needle holders	74
JACOBSON Hook	170
JACOBSON Ligature fork	196
JACOBSON Micro forceps	43
JACOBSON Micro needle holders	74
JACOBSON Micro scissors	24
JACOBSON Vessel knife	192
JAMESON REYNOLDS Dissecting scissors	18
JANSEN ZAUFAL Bone rongeur	123
Jeweler's forceps	39, 58-59
JOHNS-HOPKINS	
Applying and removing forceps	87
JOHNS-HOPKINS Bulldog clamp	87
JULIAN HM Needle holders	70
JULIAN Needle holders	70
<b>K</b>	
KERRISON "DieBlauen" Rongeurs	153-157
KERRISON Dismantable rongeurs	155-157
KERRISON (FERRIS-SMITH) Rongeurs	164
KERRISON (MICRO) Rongeurs	160-163
KERRISON (SCHLESINGER) Rongeurs	159
KERRISON (SPURLING) Rongeurs	158
KEY Raspatories	111
KEY LISTON Bone cutting forceps	127
KILLIAN Septum elevator	107
KLEINERT-KUTZ Bone rongeurs	119
KLIMA-ROSEGGER Puncture cannula	81
Knives diamond	185-187
Knives lancet	195
Knives tumor	194
Knives vessel	192-193
KOCHER MATHIEU HM Needle holder	71
KOOS Vessel knives	193
KRÄMER Raspatories	109
KRAYENBÜHL Hooks	169
KUTZ KLEINERT Bone rongeurs	119
<b>L</b>	
LAHEY CLINIC Skin hook	173
LAMBOTTE Raspatories	111
Lamina chisel	257
Lancet knives	195
LANDOLT Curette	254
LANDOLT CUSHING Specula	263
LANDOLT Enucleators	256
LANDOLT Hook	255
LANDOLT Scalpel handles	6
LANDOLT Spoon	254
LANDOLT Spreading forceps for specula	263
LANDOLT-REULEN Dissector	255
LANDOLT-REULEN Hook	255
LANDOLT-REULEN Raspatory	256
LANDOLT Tumor grasping forceps	257



**Alphabetischer Index**  
**Alphabetical Index**  
**Índice alfabético**  
**Index alphabétique**  
**Índice alfabético**

D02

ENGLISH

LANGENBECK Elevators	106
LANGENBECK HM Needle holders	72
LANGENBECK Raspatory	112
LEKSELL Bone rongeurs	125-126
LEMPERT Bone rongeurs	120
LEYLA Brain spatula retractors	202-203
LEYLA Flexible tension arm	204
Ligature fork	196
Ligature guides	196
Ligature scissors	30
LISTON-KEY Bone cutting forceps	127
LISTON LITTAUER Bone cutting forceps	128
LISTON RUSKIN Bone cutting forceps	128
LITTAUER-LISTON Bone cutting forceps	128
Lubrication of the motor	276
LUCAE Nerve hooks	166
LUER Bone rongeurs	120
LUER STILLE Bone rongeurs	124
<b>M</b>	
MARQUARDT Bone rongeur	123
MASEL Burr hole plates	243
MATHIEU HM Needle holders	71
MATHIEU Needle holders	71
MATHIEU-KOCHER HM Needle holders	71
MAYO HEGAR HM Needle holders	68
MAYO Operating scissors	13
MCINDOE Bone cutting forceps	128
MCINDOE Dressing forceps	34
MCKENZIE Perforator	150
Medicontainer	249
MEHDORN Applying forceps	92
MEHDORN Micro vessel clips	92
Mesh plate cutting scissors	30, 246
METZENBAUM Dissecting scissors	16
METZENBAUM BABY Delicate dissecting scissors	15
METZENBAUM-SLIM Dissecting scissors	17
MICHELE Skull trephines	147
MICRO 2000 Forceps	40-42, 48, 54-56
MICRO 2000 Needle holders	76, 78
MICRO 2000 Scissors	21, 26
MICRO 2000 Suturing forceps	54-56
MICRO-ADSON Delicate forceps	32
Micro button probes	189
MICRO CASTROVIEJO Micro needle holders	73
Micro curettes	198
Micro forceps	39-50
Micro forceps titanium	44, 46
Micro forceps cup jaws	259
Micro hooks	174
Micro instruments	189-198
MICRO KERRISON Rongeurs	160-163

Micro lancet knives	195
Micro ligature adjuster	196
Micro ligature guides	196
Micro needle	197
Micro needle holders titanium	77
Micro needle holders	72-78
Micro raspatories	190-192
Micro scissors	20-28, 260
Micro scissors MICRO 2000	21, 26
Micro scoops	197
Micro sharp curettes	197-198
Micro tissue claws	195
Micro tumor knives	194
Micro vessel clips	92-98
Micro vessel dilators	189
Micro vessel knives	192-193
MILLESI Micro scissors	24
MINI RUSKIN Bone rongeurs	121
MINI-RYDER HM Needle holders	70
MISKIMON Self-retaining retractor	102
MOD. AACHEN Brain spatulas	200
MOD. KÖLN Scalp clip	142
Motor tube	275
Motor with INTRA coupling	269
MÜHLING Raspatories	108
MÜLLER BIEMER Approximators	95-96
<b>N</b>	
Needle holders	65-78
Needle holders Micro	72-78
Needle holders MICRO 2000	76, 78
Needle holders titanium	77
Needle	197
NEIVERT HM Needle holder	67
Nerve hooks	166-169
Nerve separators	174-175
Neuro burrs	273
Neuro-fixation system	233-249
NICOLA Curettes	253-254
NICOLA Forceps cup jaws	258
NICOLA Micro scissors	260
Non-stick forceps	57-61
<b>O</b>	
OLIVECRONA Brain spatulas	201
OLIVECRONA Dissectors	177
OLIVECRONA GIGLI Wire saws	148
OLIVECRONA Raspatory	110
OLIVECRONA Trigeminal scissors	29
Operating scissors	10-13
<b>P</b>	
PAPAVERO-CASPAR Specula	264
PAPAVERO Lamina chisel	257
PAPAVERO-HARTMANN Spreader for specula	264



PEN Suction cannulas	79-80
PENFIELD Dissectors	178-179
Perforators	150
PETERSEN SMITH Bone rongeurs	122
Plate cutting pliers	246
Plate bending pliers	247
Plate holding forceps	247
Pneumatic high speed motors	144, 269-270
POTTS-SMITH Forceps, dressing/tissue	34
POTTS-SMITH Vascular scissors	19-20
POTTS-YASARGIL Micro scissors	24
Probes button	189
Punches skull	146
Puncture cannulas	81
<b>Q</b>	
QUINCKE Puncture cannulas	81
<b>R</b>	
RAIMONDI Scalp forceps	88
RALK Hand drill	152
RANEY Scalp clips	140-141
Raspatories	108-117, 190-192, 256
RAY Curettes	252
Removing forceps	87
Removing forceps for cerebrovascular clips	229
Removing forceps for scalp clips	140-141
Retractors delicate	100
Retractors self-retaining	101-104
REULEN LANDOLT Dissector	255
REULEN LANDOLT Hook	255
REULEN LANDOLT Raspatory	256
REYNOLDS (JAMESON) Dissecting scissors	18
RHOTON Button probe	189
RHOTON Dissectors	182
RHOTON Hooks	171
RHOTON Needle	197
RHOTON Raspatories	191
RHOTON Sharp curettes	197
RIECHERT Fixation bases	204
RIECHERT Holder for flat brain spatulas	204
Rongeurs	153-164
Rongeurs bone	119-127
ROSEGGGER KLIMA Puncture cannula	81
Rosen burrs	272
RUSKIN Bone rongeurs	121-122
RUSKIN-LISTON Bone cutting forceps	128
RUSKIN-MINI Bone rongeurs	121
RYDER MINI HM Needle holders	70
<b>S</b>	
SACHS Separator	175
SAMII Lancet knives	195

SAMII Tumor knives	194
Scalp clips	139-142
Scalp forceps	88
Scalp retractor	103
Scalpel blades	4-6
Scalpel handles	4-6
Scalpels	3-6
SCHLESINGER KERRISON Rongeurs	159
SCHMIEDEN (TAYLOR) Dura scissors	29
Scissors	7-30
Scissors delicate	10, 14-15
Scissors dissecting	14-18
Scissors dura	29
Scissors ligature	30
Scissors Mesh plate cutting	30, 246
Scissors micro	20-28, 260
Scissors MICRO 2000	21, 26
Scissors operating	10-13
Scissors trigeminal	29
Scissors tumor	22
Scissors wire	30, 246
Scissors vascular	19-20
Screw holding forceps	247
Screwdriver blades	241, 245, 250
Screwdriver handles	241, 245, 250
SEDILLOT Raspatories	109
SELECT Delicate forceps	33
SEMB-STILLE Bone rongeurs	124
SEMKEN Delicate forceps	33
Separators	174-175
Septum elevators	107
Sharp curettes	197-198
SHEA Delicate dissecting scissors	14
SHERMAN STILLE Hand drill	151
Skin hooks	172-173
Skull punches	146
Skull traction tongs	149
Skull trephines	147
SLIM Delicate dissecting scissors	15
SLIM METZENBAUM Dissecting scissors	17
SMITH FERRIS KERRISON Rongeurs	164
SMITH POTTS Forceps, dressing/tissue	34
SMITH POTTS Vascular scissors	19-20
SMITH-PETERSEN Bone rongeurs	122
SMITHWICK Sympathectomy hook	176
SÖRENSEN Head rests	134-137
Spatulas brain	200-201
Specula	263-264
Specula spreader	264
Specula spreading forceps	263
Spherical burrs	150
Splash guard for dermabrasion	274



**Alphabetischer Index**  
**Alphabetical Index**  
**Índice alfabético**  
**Index alphabétique**  
**Índice alfabético**

D02

ENGLISH

Spray adaptor	276
Spreader for specula	264
Spreading forceps	263
SPURLING KERRISON Rongeurs	158
STELLBRINK Bone rongeurs	119
STILLE Bone rongeur	126
STILLE Hand drill	151
STILLE-LUER Bone rongeurs	124
STILLE SEMB Bone rongeurs	124
STILLE-SHERMAN Hand drill	151
STRAIGHT Skin hook	173
STRULLY Trigeminal scissors	29
Suction and irrigating instruments	80-83
Suction cannulas	80, 82-83
Suction cannulas "drop shape design"	83
Suturing forceps	54-56
Sympathectomy hook	176
<b>T</b>	
TAYLOR CUSHING Bayonet forceps	51
TAYLOR CUSHING HM Bayonet forceps	51
TAYLOR SCHMIEDEN Dura scissors	29
Tissue claws	195
Titanium Bulldog clamps	85
Titanium clips	90
Titanium micro forceps	44, 46
Titanium micro needle holders	77
Titanium plates	234-239, 242-243, 250
Titanium screws	240, 244, 250
TOENNIS Dissectors	180
TOENNIS HM Needle holders	72
TOENNIS Hook	174
TOENNIS Tumor grasping forceps	53
Tools tray	276
Tray for cleaning	276
Tray for neurofixation	248
Trays for cerebrovascular clips	230-232
Trepan motor	144
Trepanation burrs	145
Trepine	151
Trigeminal scissors	29
Tumor grasping forceps	53, 257
Tumor knives	194
Tumor scissors	22
TUOHY Puncture cannulas	81
Twist drills	151-152, 241, 245, 250, 274
<b>U</b>	
UNIVERSAL HM	
Wire and Mesh plate cutting scissors	30, 246
UNIVERSAL	
Wire and Mesh plate cutting scissors	30
<b>V</b>	
Vascular forceps atraumatic	36-37

Vascular scissors	19-20
Vertebra burrs	273
Vessel clips	89-98
Vessel dilators	189
Vessel hooks	169
Vessel knives	192-193
VIPAIR - System	
Pneumatic high speed	143-145, 265-276
<b>W</b>	
WAGNER Raspatories	117
Wall tubes	275
WEITLANER Self-retaining retractor	101-102
WEITLANER-BECKMANN	
Self-retaining retractor	104
WILLIGER Raspatories	108
Wire and Mesh plate cutting scissors	30, 246
Wire and plate cutting pliers	246
Wire basket	249
Wire saws	148
WOOD CRILE BABY HM Needle holders	70
WOOD CRILE BABY Needle holders	69
WOOD CRILE HM (DEBAKEY HM)	
Needle holders	69
WOOD CRILE Needle holders	69
<b>Y</b>	
YASARGIL Applying forceps	
for cerebrovascular clips	221-228
YASARGIL Cerebrovascular clips	207-220
YASARGIL Cerebrovascular clips "Mini"	219-220
YASARGIL Cerebrovascular clips "Standard"	209-218
YASARGIL Dissector	181
YASARGIL Forceps cup jaws	258
YASARGIL Galea hooks	142
YASARGIL Grasping forceps	260
YASARGIL Ligature guides	196
YASARGIL Micro forceps	47, 49-50
YASARGIL Micro needle holders	74, 78
YASARGIL Micro scissors	24, 26-28
YASARGIL POTTS Micro scissors	24
YASARGIL Raspatories	191-192
YASARGIL Removing forceps	
for cerebrovascular clips	229
YASARGIL Suction tubes	82
YASARGIL Tissue claws	195
YASARGIL Tumor grasping forceps	53
YASARGIL Vessel knives	193
<b>Z</b>	
ZAUFAL-JANSEN Bone rongeur	123





<b>A</b>	
ACLAND Aproximadores	97
ACLAND Micro clips vasculares	93, 97
ACLAND Pinzas para aplicar	93, 97
Adaptador de spray	276
ADSON-ANDERSON	
Separador autoestático	103
ADSON Elevador	107
ADSON Ganchitos	172
ADSON HM Pinzas finas	32
ADSON JACOBSON Micro pinzas	40
ADSON Legras	110
ADSON MICRO Pinzas finas	32
ADSON Pinzas finas	32
ADSON Pinza guía de taladros	147
ADSON Separadores autoestáticos	103
Aguja	197
Alicates para cortar alambre y placas	246
ANDERSON ADSON	
Separador autoestático	103
Aproximadores	94-98
AUSTIN Pinza para sutura	56
<b>B</b>	
BABY-CRILE-WOOD HM Porta-aguja	70
BABY-CRILE-WOOD Porta-aguja	69
BABY DANDY Pinza hemostática	88
BABY-METZENBAUM	
Tijeras finas para disección	15
BACON Pinza gubia	120
BAILEY DE MARTEL	
Instrumentos para la introducción	148
Bandeja de limpieza	276
BARRAQUER Micro porta-agujas	73
BAUMGARTNER HM Porta-aguja	67
BECKMANN WEITLANER	
Separadores autoestáticos	104
BEYER Pinzas gubias	119, 123
BIEMER Aproximadores	94, 98
BIEMER Llave de repuesto	98
BIEMER Micro clips vasculares	94
BIEMER Micro tijera	23
BIEMER-MÜLLER Aproximadores	95-96
BIEMER Pinzas para aplicar	94-96
BIER Cánulas para punción	81
Bisturís	3-6
Broca espiral	241, 245, 250
Broca plano	150
Brocas helicoidales	150
Brocas	150-151, 272-274
Brocas espirales	151-152, 274
Brocas para cemento	273
Brocas Rosen	272

<b>C</b>	
Cabezales de trabajo	145, 271
Cables de conexión bipolar	64
Caja para instrumentos	187
Caja para terminales	276
Cajas para clips cerebrovascular	230-232
Caja para la neurofijación	248
Cánulas de aspiración	80, 82-83
Cánulas de aspiración con dispositivo en forma de "gota"	83
Cánulas de aspiración en forma de bayoneta	83
Cánulas para punción	81
CASPAR Disectores	183-184
CASPAR Ganchitos para exploración	176
CASPAR Legras	108
CASPAR PAPAVERO Espéculos	264
CASTROVIEJO HM Micro porta-agujas	72-73
CASTROVIEJO Micro porta-agujas	72
CASTROVIEJO-MICRO Micro porta-agujas	73
Cestille	249
Cinzel para lámina	257
Clamps	85-88
Clamps atraumáticas	85, 87
Clamps Bulldog	85-87
Clamps Bulldog atraumáticas	85, 87
Clamps Bulldog titanio	85
CLINIC LAHEY Ganchito para piel	173
Clips de titanio	
Clips hemostáticos para cuero cabelludo	139-142
Clips vasculares	89-98
Clips cerebrovascular	207-220
Clips cerebrovascular "Mini"	219-220
Clips cerebrovascular "Standard"	209-218
COBB Legras	116
CONE Pinza saca-bocada para craneotomía	146
Contenedor doble	276
Contenedor para la esterilización	249
CONTOUR Separador autoestático	103
Cráneotomos	145
CRILE Ganchitos	172
CRILE-WOOD BABY HM Porta-aguja	70
CRILE-WOOD BABY Porta-aguja	69
CRILE-WOOD HM (DEBAKEY HM) Porta-agujas	69
CRILE-WOOD Porta-agujas	69
CRUTCHFIELD Perforador	151
CRUTCHFIELD Pinzas craneales de tracción	149
Cucharilla	254
Cucharillas cortantes	197-198
Cuchillos de diamante	185-187
Cuchillos en forma de lancete	195
Cuchillos para tumores	194



**Alphabetischer Index**  
**Alphabetical Index**  
**Indice alfabético**  
**Index alphabétique**  
**Indice alfabetico**

D03

Cuchillos para vasos	192-193
Curetas	198, 252-254
CUSHING Broca plano	150
CUSHING Ganchitos para nervios	167
CUSHING HM Pinzas anatómicas/quirúrgicas	35
CUSHING-LANDOLT Espéculos	263
CUSHING Legras	112
CUSHING Pinzas anatómicas/quirúrgicas	35
CUSHING (TAYLOR) HM	
Pinza en forma bajoneta	51
CUSHING (TAYLOR) Pinzas en forma bajoneta	51
<b>D</b>	
DAHLGREN Pinza saca-bocada para craneotomía	146
DANDY-BABY Pinza hemostática	88
DANDY Pinzas hemostáticas	88
DAVIS Disector	177
DAVIS Espátulas cerebrales	200
DAVIS Separador	175
DEBAKEY AT Clamps Bulldog	87
DEBAKEY AT Pinzas atraumáticas	38-39
DEBAKEY AT	
Pinzas vasculares atraumáticas	36-37
DEBAKEY HM Porta-agujas	69
DE MARTEL (BAILEY)	
Instrumento para la introducción	148
DENNIS Micro pinzas	45
D'ERRICO Broca helicoidal	150
DEVILBISS	
Pinza saca-bocadas para craneotomía	146
DIEFFENBACH Clamps Bulldog	86
DIETHRICH Clamps Bulldog	86
DIETHRICH HEGEMANN Tijeras vasculares	19
Dilatadores vasculares	189
Disectores	177-184, 255, 261
Disectores para duramadre	177
Dispositivo	64
<b>E</b>	
ECHLIN Pinzas gubias	127
EIF Ganchito	169
Elevadores	106-107
Elevadores para el tabique nasal	107
Enucleadores	256, 262
Espátulas cerebrales	200-201
Espéculos	263-264
<b>F</b>	
FARABEUF Legras	110
FERGUSSON FRAZIER	
Instrumentos de aspiración	82
FERRIS-SMITH KERRISON	
Pinzas saca-bocadas	164
Fijadores craneales	134-137

FISCH Ganchito	170
FIXIT Systema de fijación craneal	131-138
FRAZIER (FERGUSSON)	
Instrumentos de aspiración	82
FRAZIER Ganchito para duramadre y piel	173
FRAZIER Instrumentos de aspiración	81-82
FRAZIER Separador	174
FREER Elevadores	107
FREER Legra	108
Fresas	150-151, 272-274
Fresas "Flameshape"	273
Fresas cilíndricas	273
Fresas cilíndricas de diamante	272
Fresas de trepano	145
Fresas neuro	273
Fresas para craneotomo	145
Fresas para la dermoabrasión	274
Fresas para vértebras	273
Fresas redondas	150
Fresas redondas de diamante	272
FRIEDMANN Pinza gubia	119
<b>G</b>	
GALT Trépanos craneales	147
Ganchitos	170-171, 255
Ganchitos para duramadre	172-173
Ganchitos para exploración	176
Ganchitos para nervios	166-169
Ganchitos para piel	172-173
Ganchitos para vasos	169
Gancho simpatectomia	176
Ganchos	166-176, 255
Ganchos para galea	142
Ganchos y disectores	165-184, 255
Garras para tejido	195
GIGLI (OLIVECRONA) Sierras de hilo de acero	148
GIGLI Mangos	148
GILLIES Ganchitos	173
GILLIES Pinza quirúrgica	34
GREENBERG PAR Tijeras finas para disección	14
GRUENWALD Pinzas en forma bajoneta	51
Guías-ligaduras	196
<b>H</b>	
HALSEY HM Porta-aguja	67
HARDY Curetas	253
HARDY Disectores	261
HARDY Enucleadores	262
HARDY Horquilla para implantar	262
HARTMANN PAPAVERO	
Separador para espéculos	264
HEGAR MAYO HM Porta-agujas	68
HEGEMANN-DIETHRICH Tijeras vasculares	19
HM Alicates para cortar alambre y placas	246



HM Pinzas	32, 35, 52
HM Tijeras para cortar alambre y placas Mesh	246
HM Tijeras para ligaduras	30
HOEN Elevadores	106
HOEN Pinza para cuero cabelludo	88
HOEN Separadores	174
Hojas de bisturí	4-6
Hojas para atornillador	241, 245, 250
HOPKINS JOHNS Clamps Bulldog	87
HOPKINS JOHNS Pinza para aplicar y quitar	87
Horquilla de hilos	196
Horquilla para implantar	262
HORSLEY Separador	175
HUDSON Perforador de mano	150
HUNT Pinzas para agarrar tumores	52
<b>I</b>	
Instrumento de adaptación	248
Instrumentos de aspiración y de lavado	80-83
Instrumentos de microcirugía	189-198
Instrumentos para la introducción	148
Instrumentos para la trepanación y craneotomía	143-152
Instrumento para medir la profundidad	248
Interruptor a pedal	275
<b>J</b>	
JACOBSON-ADSON Micro pinzas	40
JACOBSON Cuchillo para vaso	192
JACOBSON Sonda abotonada	189
JACOBSON Ganchito	170
JACOBSON HM Micro porta-agujas	74
JACOBSON Horquilla de hilos	196
JACOBSON Micro pinzas	43
JACOBSON Micro porta-agujas	74
JACOBSON Micro tijera	24
JAMESON REYNOLDS Tijeras para disección	18
JANSEN ZAUFAL Pinza gubia	123
JOHNS-HOPKINS Clamps Bulldog	87
JOHNS-HOPKINS Pinza para aplicar y quitar	87
JULIAN HM Porta-agujas	70
JULIAN Porta-agujas	70
<b>K</b>	
KERRISON "DieBlauen" Pinzas saca-bocadas	153-157
KERRISON (FERRIS-SMITH) Pinzas saca-bocadas	164
KERRISON (MICRO) Pinzas saca-bocadas	160-163
KERRISON (SCHLESINGER) Pinzas saca-bocadas	159
KERRISON (SPURLING) Pinzas saca-bocadas	158
KERRISON Pinzas saca-bocadas desmontable	155-157
KEY Legras	111
KEY LISTON Pinza cortante para huesos	127

KILLIAN Elevador para el tabique nasal	107
KLEINERT-KUTZ Pinzas gubias	119
KLIMA-ROSEGGER Cánulas para punción	81
KOCHER MATHIEU HM Porta-agujas	71
KOOS Cuchillos para vasos	193
KRÄMER Legras	109
KRAYENBÜHL Ganchitos	169
KUTZ KLEINERT Pinzas gubias	119
<b>L</b>	
LAHEY CLINIC Ganchito para piel	173
LAMBOTTE Legras	111
LANDOLT Cucharilla	254
LANDOLT Cureta	254
LANDOLT CUSHING Espéculos	263
LANDOLT Eucleadores	256
LANDOLT Ganchito	255
LANDOLT Mangos de bisturí	6
LANDOLT Pinza dilatatore para espéculos	263
LANDOLT Pinza para agarrar tumores	257
LANDOLT-REULEN Disector	255
LANDOLT-REULEN Ganchito	255
LANDOLT-REULEN Legra	256
LANGENBECK Elevadores	106
LANGENBECK HM Porta-agujas	72
LANGENBECK Legra	112
Legras	108-117, 190-191, 256
LEKSELL Pinzas gubias	125-126
LEMPERT Pinzas gubias	120
LEYLA Brazo tensor flexible	204
LEYLA Separadores para espátulas cerebrales	202-203
LISTON-KEY Pinza cortante para huesos	127
LISTON LITTAUER Pinza cortante para huesos	128
LISTON RUSKIN Pinzas cortante para huesos	128
LITTAUER-LISTON Pinza cortante para huesos	128
Lubrificante para el motor	276
LUCAE Ganchitos para nervios	166
LUER Pinzas gubias	120
LUER STILLE Pinzas gubias	124
<b>M</b>	
Mangos	148
Mangos de bisturí	4-6
Mangos para atornillador	241, 245, 250
MARQUARDT Pinza gubia	123
MASEL Placas para tapar los orificios perforados	243
MATHIEU HM Porta-agujas	71
MATHIEU-KOCHER HM Porta-agujas	71
MATHIEU Porta-agujas	71



**Alphabetischer Index**  
**Alphabetical Index**  
**Indice alfabético**  
**Index alphabétique**  
**Indice alfabético**

D03

MAYO-HEGAR HM Porta-agujas	68
MAYO Tijeras quirúrgicas	13
MCINDOE Pinzas cortantes para huesos	128
MCINDOE Pinza anatómica	34
MCKENZIE Broca helicoidal	150
MEHDORN Micro clips vasculares	92
MEHDORN Pinza para aplicar	92
METZENBAUM Tijeras para disección	16
METZENBAUM BABY Tijeras finas para disección	15
METZENBAUM-SLIM Tijeras para disección	17
MICHELE Trépanos craneales	147
MICRO 2000 Pinzas para sutura	54-56
MICRO 2000 Porta-agujas	76, 78
MICRO 2000 Tijeras	21, 26
MICRO 2000 Pinzas	40-42, 48, 54-56
MICRO-ADSON Pinzas finas	32
Micro aguja	197
MICRO CASTROVIEJO Micro porta-agujas	73
Micro clips vasculares	92-98
Micro cucharillas	197-198
Micro cuchillos en forma de lanceta	195
Micro cuchillos para tumores	194
Micro cuchillos para vasos	192-193
Micro curetas	198
Micro dilataores vasculares	189
Micro garras para tejido	195
Micro guías-ligaduras	196
Micro horquilla de hilos	196
Micro instrumentos	189-198
Micro pinzas titanio	44, 46
Micro sondas abotonados	189
Micro ganchitos	174
MICRO KERRISON Pinzas saca-bocadas	160-163
Micro legras	191-192
Micro pinzas	39-50
Micro pinzas con boca de cucharilla	259
Micro porta-agujas	72-78
Micro porta-agujas titanio	77
Micro tijeras	20-28, 260
Micro tijeras MICRO 2000	21, 26
MILLES I Micro tijeras	24
MINI RUSKIN Pinzas gubias	121
MINI-RYDER HM Porta-agujas	70
MISKIMON Separador autoestático	102
MOD. AACHEN Espátulas cerebrales	201
MOD. KÖLN Clip hemostático para cuero cabelludo	142
Motor angulado	144, 270
Motor con acoplamiento INTRA	269
Motor de trépano	144

Motores neumáticos	144, 269-270
MÜHLING Legras	108
MÜLLER BIEMER Aproximadores	95-96

<b>N</b>	
NEIVERT HM Porta-aguja	67
NICOLA Curetas	253-254
NICOLA Micro tijera	260
NICOLA Pinza con boca de cucharilla	258

<b>O</b>	
OLIVECRONA Disectores	177
OLIVECRONA Espátulas cerebrales	201
OLIVECRONA GIGLI Sierras de hilo de acero	148
OLIVECRONA Legra	110
OLIVECRONA Tijera para trigémino	29

<b>P</b>	
PAPAVERO-CASPAR Espéculos	264
PAPAVERO Cíncel para lámina	257
PAPAVERO-HARTMANN Separador para espéculos	264
PEN Cánulas de aspiración	79-80
PENFIELD Disectores	178-179
Perforadores de mano	150-152
PETERSEN SMITH Pinzas gubias	122
Pinza dilatador	263
Pinza para aplicar	92-97
Pinza saca-bocada desmontable	153-157
Pinzas	31-63
Pinzas anatómicas/quirúrgicas	32-35
Pinzas atraumáticas	36-39
Pinzas bipolares	58-63
Pinzas bipolares no adherentes	57-61
Pinzas con boca de cucharilla	258-259
Pinzas cortantes para huesos	127-128
Pinzas craneales de tracción	149
Pinzas de agarre para placas	247
Pinzas de agarre para tornillos	247
Pinzas en forma de bajoneta	47-53, 60-63
Pinzas finas, anatómicas y quirúrgicas	32-33
Pinzas gubias	119-127
Pinzas guía de taladros	147
Pinzas hemostáticas	88
Pinzas HM	32, 35, 52
Pinzas micro	39-50
Pinzas MICRO 2000	40-42, 48, 54-56
Pinzas micro titanio	44, 46
Pinzas no adherentes	57-61
Pinzas para agarrar	53, 260, 257
Pinzas para agarrar tumores	53, 261, 257
Pinzas para aplicar	92-97
Pinzas para aplicar clamps Bulldog	87
Pinzas para aplicar clips cerebrovascular	221-228



Pinzas para aplicar para clips de titanio	91
Pinzas para aplicar y quitar	140-141
Pinzas para cuero cabelludo	88
Pinzas para doblar placas	247
Pinzas para joyero/relojero	39, 58-59
Pinzas para quitar	87
Pinzas para quitar clips vasculares cerebrales	229
Pinzas para sutura	54-56
Pinzas saca-bocadas	153-164
Pinzas saca-bocadas desmontable	155-157
Pinzas saca-bocadas para craneotomía	146
Pinzas vasculares atraumáticas	36-37
Placas de titanio	234-239, 242-243, 250
Placas para tapar los orificios perforados	235, 243
Porta-agujas	65-78
Porta-agujas micro	72-78
Porta-agujas MICRO 2000	76, 78
Porta-agujas titanio	77
POTTS-SMITH Pinzas anatómicas/quirúrgicas	34
POTTS-SMITH Tijeras vasculares	19-20
POTTS-YASARGIL Micro tijera	24
Protección contra riego para la dermabrasion	274
<b>Q</b>	
QUINCKE Cánulas para punción	81
<b>R</b>	
RAIMONDI Pinza para cuero cabelludo	88
RALK Perforador de mano	152
RANEY	
Clips hemostáticos para cuero cabelludo	140-141
RAY Curetas	252
REULEN LANDOLT Disector	255
REULEN LANDOLT Ganchito	255
REULEN LANDOLT Legra	256
REYNOLDS (JAMESON) Tijeras para disección	18
RHOTON Aguja	197
RHOTON Cucharillas cortantes	197
RHOTON Disectores	182
RHOTON Sonda abotonada	189
RHOTON Ganchitos	171
RHOTON Legras	191
RIECHERT Fijadores	204
RIECHERT	
Soporte para espátulas cerebrales planas	204
ROEGGER KLIMA Cánulas para punción	81
RUSKIN Pinzas gubias	121-122
RUSKIN-LISTON	
Pinzas cortantes para huesos	128
RUSKIN-MINI Pinzas gubias	121
RYDER MINI HM Porta-agujas	70
<b>S</b>	
SACHS Separador	175
SAMII Cuchillos en forma de lanceta	195

SAMII Cuchillos para tumores	194
SCHLESINGER KERRISON	
Pinzas saca-bocadas	159
SCHMIEDEN (TAYLOR)	
Tijeras para duramadre	29
SEDILLOT Legras	109
SELECT Pinzas finas	33
SEMB-STILLE Pinzas gubias	124
SEMKEN Pinzas finas	33
Separador para el cuero cabelludo	103
Separador para espéculos	264
Separadores	99-100, 174-175
Separadores autoestáticos	101-104
Separadores finos	100
Separadores para duramadre	174-175
Separadores para espátulas cerebrales	202-206
Separadores para nervios	174-175
SHEA Tijeras finas para disección	14
SHERMAN STILLE Perforador de mano	151
Sierras de hilo de acero	148
Sistema para neuro-fijación	233-249
Sistemas de fijación craneal	131-138
SLIM METZENBAUM Tijeras para disección	17
SLIM Tijeras finas para disección	15
SMITH FERRIS KERRISON	
Pinzas saca-bocadas	164
SMITH POTTS Pinzas anatómicas/quirúrgicas	34
SMITH POTTS Tijeras vasculares	19-20
SMITH-PETERSEN Pinzas gubias	122
SMITHWICK Gancho simpatectomia	176
Sondas abotonadas	189
SÖRENSEN Fijadores craneales	134-137
SPURLING KERRISON Pinzas saca-bocadas	158
STELLBRINK Pinzas gubias	119
STILLE Perforador de mano	151
STILLE Pinza gubia	126
STILLE-LUER Pinzas gubias	124
STILLE SEMB Pinzas gubias	124
STILLE-SHERMAN Perforador de mano	151
STRAIGHT Ganchito para piel	173
STRULLY Tijera para trigémino	29
<b>T</b>	
TAYLOR CUSHING HM	
Pinza en forma bajoneta	51
TAYLOR CUSHING Pinzas en forma bajoneta	51
TAYLOR SCHMIEDEN Tijeras para duramadre	29
Tijeras	
Tijeras finas	7-30
Tijeras finas para disección	10, 14-16
Tijeras finas para disección	14-15
Tijeras micro	20-28, 260
Tijeras MICRO 2000	21, 26
Tijeras para cortar alambre y placas Mesh	30, 246



Tijeras para disección	14-18
Tijeras para duramadre	29
Tijeras para ligaduras	30
Tijeras para trigémino	29
Tijeras para tumores	22
Tijeras quirúrgicas	10-13
Tijeras vasculares	19-20
Titanio clamps Bulldog	85
Titanio Clips	90
Titanio micro pinzas	44, 46
Titanio micro porta-agujas	77
TOENNIS Disectores	180
TOENNIS Gancho	174
TOENNIS HM Porta-agujas	72
TOENNIS Pinzas para agarrar tumores	53
Tornillos de titanio	240, 244, 250
Trépano	151
Trépanos craneales	147
Tubos de irrigación	271
Tubos de motor	275
Tubos murales	275
TUOHY Cánulas para punción	81
<b>U</b>	
UNIVERSAL HM Tijera para cortar alambre y placas Mesh	30, 246
UNIVERSAL Tijera para cortar alambre y placas Mesh	30
<b>V</b>	
VIPAIR - Sistema de motor neumático	143-145, 265-276
<b>W</b>	
WAGNER Legras	117
WEITLANER Separadores autoestáticos	101-102
WEITLANER-BECKMANN Separadores autoestáticos	104
WILLIGER Legras	108
WOOD CRILE BABY HM Porta-aguja	70
WOOD CRILE BABY Porta-aguja	69
WOOD CRILE HM (DEBAKEY HM) Porta-agujas	69
WOOD CRILE Porta-agujas	69
<b>Y</b>	
YASARGIL Clips cerebrovascular	207-220
YASARGIL Clips cerebrovascular "Mini"	219-220
YASARGIL Clips cerebrovascular "Standard"	209-218
YASARGIL Cuchillos para vasos	193
YASARGIL Disector	181
YASARGIL Ganchos para galea	142
YASARGIL Garras para tejido	195
YASARGIL Guías-ligaduras	196

YASARGIL Legras	191-192
YASARGIL Micro pinzas	47, 49-50
YASARGIL Micro porta-agujas	74, 78
YASARGIL Micro tijeras	24, 26-28
YASARGIL Pinzas con boca de cucharilla	258
YASARGIL Pinzas para agarrar	260
YASARGIL Pinzas para agarrar tumores	53
YASARGIL Pinzas para aplicar clips cerebrovascular	221-228
YASARGIL Pinzas para quitar clips cerebrovascular	229
YASARGIL POTTS Micro tijera	24
YASARGIL Tubos aspirador	82
<b>Z</b>	
ZAUFAL-JANSEN Pinza gubia	123

<b>A</b>	
ACLAND Approximateurs	97
ACLAND Micro clips vasculaires	93, 97
ACLAND Pincés à appliquer	93, 97
Adaptateur du spray	276
ADSON-ANDERSON Ecarteur autostatique	103
ADSON Crochets	172
ADSON Ecarteurs autostatiques	103
ADSON Elévateur	107
ADSON HM Pincés délicates	32
ADSON JACOBSON Micro pincés	40
ADSON MICRO Pincés délicates	32
ADSON Pincés délicates	32
ADSON Pincés guide-forêt	147
ADSON Rugines	110
Aiguille	197
ANDERSON ADSON Ecarteur autostatique	103
Approximateurs	94-98
AUSTIN Pince à sutures	56
<b>B</b>	
BABY-CRILE-WOOD HM Porte-aiguille	70
BABY-CRILE-WOOD Porte-aiguille	69
BABY DANDY Pince hémostatique	88
BABY-METZENBAUM	
Ciseaux délicats pour dissection	15
BACON Pince-gouge	120
BAILEY DE MARTEL Instrument à introduire	148
BARRAQUER Micro porte-aiguilles	73
BAUMGARTNER HM Porte-aiguille	67
BECKMANN WEITLANER	
Ecarteurs autostatiques	104
BEYER Pincés-gouges	119, 123
BIEMER Approximateurs	94, 98
BIEMER Clé de rechange	98
BIEMER Micro ciseaux	23
BIEMER Micro clips vasculaires	94
BIEMER-MÜLLER Approximateurs	95-96
BIEMER Pincés à appliquer	94-96
BIER Canules à ponction	81
Bistouris	3-6
<b>C</b>	
Câbles connecteurs bipolaires	64
Canules à aspiration	80, 82-83
Canules à aspiration	
avec dispositif en forme de "goutte"	83
Canules à aspiration en forme baïonnette	83
Canules à ponctions	81
CASPAR Crochets pour exploration	176
CASPAR Dissecteurs	183-184
CASPAR PAPAVERO Spéculums	264
CASPAR Rugines	108
Cassette pour instruments	187

Cassette pour outils	276
Cassettes pour clips vasculaires cérébraux	230-232
Cassettes pour la neurofixation	248
CASTROVIEJO HM Micro-porte-aiguilles	72-73
CASTROVIEJO Micro porte-aiguilles	72
CASTROVIEJO-MICRO Micro porte-aiguilles	73
Ciseaux	7-30
Ciseaux à ligatures	30
Ciseaux burins pour les lames	257
Ciseaux chirurgicaux	10-13
Ciseaux coupe-fil et	
coupe-plaques Mesh	30, 246
Ciseaux délicats	10, 14-15
Ciseaux délicats pour dissection	14-15
Ciseaux pour dissection	14-18
Ciseaux micro	20-28, 260
Ciseaux MICRO 2000	21, 26
Ciseaux pour dure-mère	29
Ciseaux pour trijumeau	29
Ciseaux pour tumeur	22
Ciseaux vasculaires	19-20
Clamps	85-88
Clamps atraumatiques	85, 87
Clamps Bulldog	85-87
Clamps Bulldog atraumatiques	85, 87
Clamps Bulldog en titane	85
CLINIC LAHEY Crochet pour peau	173
Clips en titane	90
Clips hémostatiques pour cuir chevelu	139-142
Clips vasculaires	89-98
Clips vasculaires cérébraux	207-220
Clips vasculaires cérébraux "Mini"	219-220
Clips vasculaires cérébraux "Standard"	209-218
COBB Rugines	116
CONE Pince emporte-pièce crâniennes	146
Container double	276
Container pour la stérilisation	249
CONTOUR Ecarteur autostatiques	103
Couteaux à tumeurs	194
Couteaux de diamant	185-187
Couteaux lancéolaires	195
Couteaux pour vaisseaux	192-193
Crâniotomes	145
CRILE Crochets	172
CRILE-WOOD BABY HM Porte-aiguille	70
CRILE-WOOD BABY Porte-aiguille	69
CRILE-WOOD HM (DEBAKEY HM)	
Porte-aiguilles	69
CRILE-WOOD Porte-aiguilles	69
Crochet sympathectome	176
Crochets	166-176, 255
Crochets à nerfs	166-169



**Alphabetischer Index**  
**Alphabetical Index**  
**Índice alfabético**  
**Index alphabétique**  
**Índice alfabético**

D04

Crochets à vaisseaux	169
Crochets de galea	142
Crochets et dissecteurs	165-184, 255
Crochets pour dure-mère	172-173
Crochets pour exploration	176
Crochets pour peau	172-173
CRUTCHFIELD Alésoir	151
CRUTCHFIELD Pincés de traction crâne	149
Cuillères	254
Curettes	198, 252-254
Curettes tranchantes	197-198
CUSHING Crochets à nerfs	167
CUSHING Fraises en plat	150
CUSHING HM	
Pincés anatomiques/chirurgicales	35
CUSHING-LANDOLT Spéculum	263
CUSHING Pincés anatomiques/chirurgicales	35
CUSHING Rugines	112
CUSHING (TAYLOR) HM	
Pince en forme baïonnette	51
CUSHING (TAYLOR)	
Pincés en forme baïonnette	51
<b>D</b>	
DAHLGREN	
Pince emporte-pièce crâniennes	146
DANDY Pincés hémostatiques	88
DANDY-BABY Pince hémostatique	88
DAVIS Dissecteur	177
DAVIS Séparateur	175
DAVIS Spatulas cérébrales	200
DEBAKEY AT Clamps Bulldog	87
DEBAKEY AT Pincés atraumatiques	38-39
DEBAKEY AT	
Pincés vasculaires atraumatiques	36-37
DEBAKEY HM Porte-aiguilles	69
DE MARTEL (BAILEY)	
Instrument à introduire	148
DENNIS Micro pincés	45
D'ERRICO Fraise hélicoïdal	150
DEVILBISS Pincés emporte-pièce crâniennes	146
DIEFFENBACH Clamps Bulldog	86
DIETHRICH Clamps Bulldog	86
DIETHRICH HEGEMANN	
Ciseaux vasculaires	19
Dilatateurs vasculaires	189
Dispositif	64
Dissecteurs	177-184, 255, 261
Dissecteurs pour dure-mère	177
<b>E</b>	
Ecarteur pour le cuir chevelu	103
Ecarteur pour spéculum	264
Ecarteurs	99-100

Ecarteurs autostatiques	101-104
Ecarteurs fins	100
Ecarteurs pour des spatules cérébrales	202-206
Ecarteurs pour opérations cérébelleuses	103
ECHLIN Pincés-gouges	127
EIF Crochet	169
Élévateur pour la cloison nasale	107
Élévateurs	106-107
Enucléateurs	256, 262
<b>F</b>	
FARABEUF Rugines	110
FERGUSON FRAZIER	
Instruments à aspiration	82
FERRIS-SMITH KERRISON	
Pincés emporte-pièce	164
FISCH Crochet	170
FIXIT Système de maintien crânien	131-138
Foret hélicoïdal	241, 245, 250
Fourchette pour implants	262
Fraise en plat	150
Fraises	150-151, 272-274
Fraises hélicoïdales	150
Fraises "Flameshape"	273
Fraises à ciment	273
Fraises à dermabrasion	274
Fraises à trépan	145
Fraises cylindriques	273
Fraises cylindriques diamantées	272
Fraises de Rosen	272
Fraises pour crâniotome	145
Fraises en spirale	151-152, 274
Fraises forme boule	150
Fraises forme boule diamantées	272
Fraises neuro	273
Fraises vertébrales	273
FRAZIER (FERGUSON)	
Instruments à aspiration	82
FRAZIER Crochet pour dure-mère et peau	173
FRAZIER Instruments à aspiration	81-82
FRAZIER Séparateur	174
FREER Élévateurs	107
FREER Rugine	108
FRIEDMANN Pince-gouge	119
<b>G</b>	
GALT Tréphines crâniennes	147
GIGLI (OLIVECRONA) Scies en fil d'acier	148
GIGLI Manches	148
GILLIES Crochets	173
GILLIES Pince chirurgicale	34
GREENBERG PAR	
Ciseaux délicats pour dissection	14
Griffes tissulaires	195



GRUENWALD Pincen en forme baïonnette	51
Guides-fils	196
<b>H</b>	
HALSEY HM Porte-aiguille	67
HARDY Curettes	253
HARDY Dissecteurs	261
HARDY Enucléateurs	262
HARDY Fourchette pour implants	262
HARTMANN PAPAVERO Ecarteur pour spéculums	264
HEGAR MAYO HM Porte-aiguilles	68
HEGEMANN-DIETHRICH Ciseaux vasculaires	19
HM Ciseaux à ligatures	30
HM Ciseaux coupe-fils et coupe-plaques Mesh	246
HM Pincen	32, 35, 52
HM Pincen coupe-fils et coupe-plaques	246
HOEN Elévateurs	106
HOEN Pince pour le cuir chevelu	88
HOEN Séparateurs	174
HOPKINS JOHNS Clamps Bulldog	87
HOPKINS JOHNS Pince à poser et retirer	87
HORSLEY Séparateur	175
HUDSON Perforateur à main	150
HUNT Pincen pour saisir des tumeurs	52
<b>I</b>	
Instruments à aspiration et à irrigation	80-83
Instruments à introduire	148
Instruments d'adaptation	248
Instruments de microchirurgie	189-198
Instruments pour la trépanation et craniotomie	143-152
Instruments pour mesurer la profondeur	248
Interrupteur à pédale	275
<b>J</b>	
JACOBSON-ADSON Micro pincen	40
JACOBSON Couteau pour vaisseaux	192
JACOBSON Crochet	170
JACOBSON HM Micro porte-aiguilles	74
JACOBSON Micro ciseaux	24
JACOBSON Micro pincen	43
JACOBSON Micro porte-aiguilles	74
JACOBSON Pousse-fil	196
JACOBSON Sonde boutonée	189
JAMESON REYNOLDS Ciseaux pour dissection	18
JANSEN-ZAUFAL Pince-gouge	123
JOHNS-HOPKINS Clamps Bulldog	87
JOHNS-HOPKINS Pince à poser et retirer	87
JULIAN HM Porte-aiguilles	70
JULIAN Porte-aiguilles	70

<b>K</b>	
KERRISON "DieBlauen" Pincen emporte-pièce	153-157
KERRISON (FERRIS-SMITH) Pincen emporte-pièce	164
KERRISON (MICRO) Pincen emporte-pièce	160-163
KERRISON (SCHLESINGER) Pincen emporte-pièce	159
KERRISON (SPURLING) Pincen emporte-pièce	158
KERRISON Pincen emporte-pièce desmontables	153-157
KEY Rugines	111
KEY LISTON Pince coupante à os	127
KILIAN Elévateur pour la cloison nasale	107
KLEINERT-KUTZ Pincen-gouges	119
KLIMA-ROSEGGER Canule ponction	81
KOCHER MATHIEU HM Porte-aiguilles	71
KOOS Couteaux pour vaisseaux	193
KRÄMER Rugines	109
KRAYENBÜHL Crochets	169
KUTZ KLEINERT Pincen-gouges	119
<b>L</b>	
LAHEY-CLINIC Crochet pour peau	173
LAMBOTTE Rugines	111
Lames de bistouri	4-6
Lames de tournevis	241, 245, 250
LANDOLT Crochet	255
LANDOLT Curettes	254
LANDOLT CUSHING Spéculums	263
LANDOLT Enucléateurs	256
LANDOLT Manches pour bistouri	6
LANDOLT Pince écartante pour spéculums	263
LANDOLT Pince pour préhension de tumeurs	257
LANDOLT-REULEN Crochet	255
LANDOLT-REULEN Dissecteur	255
LANDOLT-REULEN Rugine	256
LANGENBECK Elévateurs	106
LANGENBECK HM Porte-aiguilles	72
LANGENBECK Rugine	112
LEKSELL Pincen-gouges	125-126
LEMPERT Pincen-gouges	120
LEYLA Bras tendeur flexible	204
LEYLA Ecarteurs pour des spatules cérébrales	202-203
LISTON-KEY Pince à os	127
LISTON LITTAUER Pince coupante à os	128
LISTON-RUSKIN Pince à os	128
LITTAUER-LISTON Pince à os	128
Lubrifiant pour le moteur	276
LUCAE Crochets à nerfs	166
LUER Pincen-gouges	120



**Alphabetischer Index**  
**Alphabetical Index**  
**Indice alfabético**  
**Index alphabétique**  
**Indice alfabético**

D04

LUER STILLE Pincers-gouges	124
<b>M</b>	
Maintiens crâniens	134-137
Manches	148
Manches de tournevis	241, 245, 250
Manches pour bistouris	4-6
MARQUARDT Pince-gouge	123
MASEL Plaques pour trous de forage	243
MATHIEU HM Porte-aiguilles	71
MATHIEU-KOCHER HM Porte-aiguilles	71
MATHIEU Porte-aiguilles	71
MAYO Ciseaux chirurgicaux	13
MAYO HEGAR HM Porte-aiguilles	68
MCINDOE Pincers coupantes à os	128
MCINDOE Pincers anatomiques	34
MCKENZIE Fraise hélicoïdale	150
MEHDORN Micro clips vasculaires	92
MEHDORN Pince à poser	92
<b>METZENBAUM BABY</b>	
Ciseaux délicats pour dissection	15
METZENBAUM Ciseaux pour dissection	16
<b>METZENBAUM-SLIM</b>	
Ciseaux pour dissection	17
MICHELE Tréphines crâniennes	147
MICRO 2000 Ciseaux	21, 26
MICRO 2000 Pincers	40-42, 48, 54-56
MICRO 2000 Pincers à suture	54-56
MICRO 2000 Porte-aiguilles	76, 78
MICRO ADSON Pincers délicates	32
Micro aiguille	197
MICRO CASTROVIEJO Micro porte-aiguilles	73
Micro ciseaux	20-28, 260
Micro ciseaux MICRO 2000	21, 26
Micro clips vasculaires	92-98
Micro couteaux à tumeurs	194
Micro couteaux lancéolaires	195
Micro couteaux pour vaisseaux	192-193
Micro crochets	174
Micro curettes	197-198
Micro dilateurs vasculaires	189
Micro griffes tissulaires	195
Micro guides-fils	196
Micro instruments	189-198
MICRO KERRISON Pincers emporte-pièce	160-163
Micro pincers mors cuillère	259
Micro pincers titane	44, 46
Micro pincers	39-50
Micro porte-aiguilles	72-78
Micro porte-aiguilles en titane	77
Micro pousse-fil	196
Micro rugines	191-192
Micro stylets boutonnés	189

MILLES Micro ciseaux	24
MINI RUSKIN Pincers-gouges	121
MINI-RYDER HM Porte-aiguilles	70
MISKIMON Ecarteur autostatique	102
MOD. AACHEN Spatulas cérébrales	200
<b>MOD. KÖLN</b>	
Clip hémostatique pour cuir chevelu	142
Moteur à trépan	144
Moteur angulaire	144, 270
Moteur avec embrayage INTRA	269
Moteurs pneumatiques	144, 269-270
MÜHLING Rugines	108
MÜLLER BIEMER Approximateurs	95-96
<b>N</b>	
NEIVERT HM Porte-aiguille	67
NICOLA Curettes	253-254
NICOLA Micro ciseaux	260
NICOLA Pince mors cuillère	258
<b>O</b>	
OLIVECRONA Ciseaux pour trijumeau	29
OLIVECRONA Dissecteurs	177
OLIVECRONA GIGLI Scies en fil d	148
OLIVECRONA Rugine	110
OLIVECRONA Spatulas cérébrales	201
<b>P</b>	
Panier	249
PAPAVERO-CASPAR Spéculums	264
PAPAVERO Ciseau burin pour les lames	257
<b>PAPAVERO-HARTMANN</b>	
Ecarteur pour spéculums	264
PEN Canules à aspiration	79-80
PENFIELD Dissecteurs	178-179
Perforateurs à main	150-152
PETERSEN SMITH Pincers-gouges	122
Pièces à main	145, 271
Pince à poser	92-97
Pince écartante	263
Pincers	31-63
Pincers à appliquer	92-97
Pincers à appliquer clips vasculaires cérébraux	221-228
Pincers à appliquer et retirer	140-141
Pincers anti-adhésives	57-61
Pincers à poser clamps Bulldog	87
Pincers à poser pour clips en titane	91
Pincers à retirer	87
Pincers à retirer clips vasculaires cérébraux	229
Pincers à saisir	53, 260, 257
Pincers à saisir pour tumeurs	53, 257
Pincers à suture	54-56
Pincers anatomiques/chirurgicales	32-35
Pincers atraumatiques	36-39



Pincés bipolaires	58-63
Pincés bipolaires anti-adhésives	57-61
Pincés coupantes à os	127-128
Pincés coupe-fils et coupe-plaques	246
Pincés délicates, anatomiques et chirurgicales	32-33
Pincés de traction crâne	149
Pincés emporte-pièce	153-164, 258
Pincés emporte-pièce crâniennes	146
Pincés emporte-pièce desmontables	155-157
Pincés en forme baïonnette	47-53, 60-63
Pincés guide-forêt	147
Pincés hémostatiques	88
Pincés HM	32, 35, 52
Pincés micro	39-50
Pincés MICRO 2000	40-42, 48, 54-56
Pincés micro titane	44, 46
Pincés mors cuillère	258-259
Pincés pour joaillier/horloger	39, 58-59
Pincés pour le cuir chevelu	88
Pincés pour plier les plaques	247
Pincés pour saisir	53
Pincés pour tenir les plaques	247
Pincés pour tenir les vis	247
Pincés vasculaires atraumatiques	36-37
Pincés-gouges	119-127
Plaques en titane	234-239, 242-243, 250
Plaques pour trous de forage	235, 243
Porte-aiguilles	65-78
Porte-aiguilles micro	72-78
Porte-aiguilles MICRO 2000	76, 78
Porte-aiguilles titane	77
POTTS-SMITH Ciseaux vasculaires	19-20
POTTS-SMITH Pincés anatomiques/chirurgicales	34
POTTS-YASARGIL Micro ciseaux	24
Pousse-fil	196
Protection anti-projections à dermabrasion	274
<b>Q</b>	
QUINCKE Canules à ponction	81
<b>R</b>	
RAIMONDI Pince pour le cuir chevelu	88
RALK Perforateur à main	152
RANEY Clips hémostatiques pour cuir chevelu	140-141
RAY Curettes	252
REULEN LANDOLT Crochet	255
REULEN LANDOLT Dissecteur	255
REULEN LANDOLT Rugine	256
REYNOLDS (JAMESON) Ciseaux pour dissection	18
RHOTON Aiguille	197
RHOTON Crochets	175

RHOTON Curettes tranchantes	197
RHOTON Dissecteurs	182
RHOTON Rugines	191
RHOTON Sone boutonnée	189
RIECHERT Bases de fixation	204
RIECHERT Support pour des spatules cérébrales plantes	204
ROSEGGER KLIMA Canule à ponction	81
Rugines	108-117, 190-192, 256
RUSKIN Pincés-gouges	121-122
RUSKIN-LISTON Pincés coupantes à os	128
RUSKIN-MINI Pincés-gouges	121
RYDER MINI HM Porte-aiguilles	70
<b>S</b>	
SACHS Séparateur	175
SAMII Couteaux à tumeurs	194
SAMII Couteaux lancéolaires	195
SCHLESINGER KERRISON Pincés emporte-pièce	159
SCHMIEDEN (TAYLOR) Ciseaux pour dure-mère	29
Scies en fil d'acier	148
SEDILLOT Rugines	109
SELECT Pincés délicates	33
SEMB-STILLE Pincés-gouges	124
SEMKEN Pincés délicates	33
Séparateurs pour dure-mère	174-175
Séparateurs pour nerfs	174-175
SHEA Ciseaux délicates pour dissection	14
SHERMAN STILLE Perforateur à main	151
SLIM Ciseaux délicates pour dissection	15
SLIM METZENBAUM Ciseaux pour dissection	17
SMITH FERRIS KERRISON Pincés emporte-pièce	164
SMITH POTTS Ciseaux vasculaires	19-20
SMITH POTTS Pincés anatomiques/chirurgicales	34
SMITH-PETERSEN Pincés-gouges	122
SMITHWICK Crochet sympathectome	176
Sondes boutonnées	189
SÖRENSEN Maintiens crâniens	134-137
Spatulas cérébrales	200-201
Spéculum	263-264
SPURLING KERRISON Pincés emporte-pièce	158
STELLBRINK Pincés-gouges	119
STILLE Perforateur à main	151
STILLE Pince-gouge	126
STILLE-LUER Pincés-gouges	124
STILLE SEMB Pincés-gouges	124
STILLE-SHERMAN Perforateur à main	151



STRAIGHT Crochet pour peau	173
STRULLY Ciseaux pour trijumeau	29
Système de neuro-fixation	233-249
Systèmes de maintien crânien	131-138

**T**

TAYLOR CUSHING HM Pince en forme baïonnette	51
TAYLOR CUSHING Pincés en forme baïonnette	51
TAYLOR SCHMIEDEN Ciseaux pour dure-mère	29
Titane micro pincés	44, 46
Titane micro porte-aiguilles	77
TOENNIS Crochet	174
TOENNIS Dissecteurs	180
TOENNIS HM Porte-aiguilles	72
TOENNIS Pincés à saisir pour tumeurs	53
Tray de nettoyage	276
Tréphine	151
Tréphines crâniennes	147
TUOHY Canules à ponction	81
Tuyaux d'irrigation	271
Tuyaux muraux	275
Tuyaux moteur	275

**U**

UNIVERSAL Ciseaux coupe-fil et coupe-plaques Mesh	30
UNIVERSAL HM Ciseaux coupe-fil et coupe-plaques Mesh	30, 246

**V**

VIPAIR - Système de moteur à air comprimé	143-145, 265-276
Vis en titane	240, 244, 250

**W**

WAGNER Rugines	117
WEITLANER Ecarteurs autostatiques	101-102
WEITLANER-BECKMANN Ecarteurs autostatiques	104
WILLIGER Rugines	108
WOOD CRILE BABY HM Porte-aiguille	70
WOOD CRILE BABY Porte-aiguille	69
WOOD CRILE HM (DEBAKEY HM) Porte-aiguilles	69
WOOD CRILE Porte-aiguilles	69

**Y**

YASARGIL Clips vasculaires cérébraux	207-220
YASARGIL Clips vasculaires cérébraux "Mini"	219-220
YASARGIL Clips vasculaires cérébraux "Standard"	209-218
YASARGIL Couteaux pour vaisseaux	193
YASARGIL Crochets de galea	142

YASARGIL Dissecteurs	181
YASARGIL Griffes tissulaires	195
YASARGIL Guides-fils	196
YASARGIL Micro ciseaux	24, 26-28
YASARGIL Micro pincés	47, 49-50
YASARGIL Micro porte-aiguilles	74, 78
YASARGIL Pincés à appliquer clips vasculaires cérébraux	221-228
YASARGIL Pincés à retirer clips vasculaires cérébraux	229
YASARGIL Pincés à saisir	260
YASARGIL Pincés mors cuillère	258
YASARGIL Pincés pour saisir des tumeurs	53
YASARGIL POTTS Micro ciseaux	24
YASARGIL Rugines	191-192
YASARGIL Tubes à aspiration	82

**Z**

ZAUFAL-JANSEN Pince-gouge	123
---------------------------	-----



<b>A</b>	
ACLAND Approssimatori	97
ACLAND Micro clip vascolari	93, 97
ACLAND Pinza per applicare	93, 97
Adattatore per spray	276
ADSON-ANDERSON Divaricatore autostatico	103
ADSON Divaricatori autostatici	103
ADSON Elevatore	107
ADSON HM Pinze delicate	32
ADSON JACOBSON Micro pinze	40
ADSON MICRO Pinze delicate	32
ADSON Periostotomi	110
ADSON Pinze delicate	32
ADSON Pinze guida-perforatore	147
ADSON Uncini	172
Ago	197
ANDERSON ADSON Divaricatore autostatico	103
Approssimatore	94-98
Artiglie per tessuti	195
AUSTIN Pinza per sutura	56
<b>B</b>	
BABY-CRILE-WOOD HM Portaghi	70
BABY-CRILE-WOOD Portaghi	69
BABY DANDY Pinza emostatica	88
BABY-METZENBAUM Forbici delicate per dissezione	15
BACON Pinza sgorbia	120
BAILEY DE MARTEL Strumento introduttore	148
BARRAQUER Micro portaghi	73
BAUMGARTNER HM Portaghi	67
BECKMANN WEITLANER Divaricatori autostatici	104
BEYER Pinze sgorbie	119, 123
BIEMER Approssimatori	94, 98
BIEMER Chiave di ricambio	98
BIEMER Micro clip vascolari	94
BIEMER Micro forbice	23
BIEMER Pinze per applicare	94-96
BIEMER-MÜLLER Approssimatori	95-96
BIER Cannule per puntura	81
Bisturi	3-6
Bisturi diamantati	185-187
<b>C</b>	
Cannule per aspirazione	80, 82-83
Cannula per aspirazione a forma di baionetta	83
Cannule per aspirazione con dispositivo a forma di "goccia"	83
Cannule per puntura	81
CASPAR Dissettori	183-184
CASPAR PAPAVERO Specoli	264
CASPAR Periostotomi	108
CASPAR Uncini per esplorazione	176

Cassetta per punte	276
Cassetta per strumenti	187
Cassetta per il neuro-fissaggio	248
Cassette per clip cerebrovascolari	230-232
CASTROVIEJO HM Micro portaghi	72-73
CASTROVIEJO Micro portaghi	72
CASTROVIEJO-MICRO Micro portaghi	73
Cavi di connessione bipolari	64
Cestello	249
Clamp Bulldog	85-87
Clamp Bulldog atraumatiche	85, 87
Clamp Bulldog titanio	85
Clamps atraumatiche	85, 87
CLINIC LAHEY Uncino per pelle	173
Clip cerebrovascolari	207-220
Clip cerebrovascolari "Mini"	219-220
Clip cerebrovascolari "Standard"	209-218
Clip emostatiche per cuoio capelluto	139-142
Clip in titanio	90
Clip vascolari	89-98
COBB Periostotomi	116
CONE Pinza per craniotomia	146
Contenitore doppio	276
Contenitore per sterilizzazione	249
CONTOUR Divaricatore autostatico	103
Coltelli lanceolati	195
Coltelli per tumori	194
Coltelli per vasi	192-193
Craniotomi	145
CRILE Uncino	172
CRILE-WOOD-BABY HM Portaghi	70
CRILE-WOOD-BABY Portaghi	69
CRILE-WOOD HM (DEBAKEY HM) Portaghi	69
CRILE-WOOD Portaghi	69
CRUTCHFIELD Perforatore	151
CRUTCHFIELD Pinze di trazione per cranio	149
Cucchiari taglienti	197-198
Cucchiaio	254
Curette	198, 252-254
CUSHING HM Pinze anatomiche/chirurgiche	35
CUSHING-LANDOLT Specoli	263
CUSHING Perforatore piatto	150
CUSHING Periostotomi	112
CUSHING Pinze anatomiche/chirurgiche	35
CUSHING (TAYLOR) HM Pinza a forma di baionetta	51
CUSHING (TAYLOR) Pinze a forma di baionetta	51
CUSHING Uncini per nervi	167
<b>D</b>	
DAHLGREN Pinza per craniotomia	146
DANDY Pinze emostatiche	88



**Alphabetischer Index**  
**Alphabetical Index**  
**Indice alfabético**  
**Index alphabétique**  
**Indice alfabetico**

D05

DANDY-BABY Pinza emostatica	88
DAVIS Dissetto	177
DAVIS Separatore	175
DAVIS Spatole cerebrali	200
DEBAKEY AT Pinze atraumatiche	38-39
DEBAKEY AT Pinze Bulldog	87
DEBAKEY AT Pinze vascolari atraumatiche	36-37
DEBAKEY HM Portaghi	69
DE MARTEL (BAILEY) Strumento introduttore	148
DENNIS Micro pinze	45
D'ERRICO Perforatore elicoidale	150
DEVILBISS Pinza per craniotomia	146
DIEFFENBACH Pinze Bulldog	86
DIETHRICH HEGEMANN Forbici vascolari	19
DIETHRICH Pinze Bulldog	86
Dilatatori vascolari	189
Dispositivo di denuta	64
Dissettori	177-184, 255, 261
Dissettori per dura-madre	177
Divaricatore per il cuoio capelluto	103
Divaricatore per specoli	264
Divaricatori autostatici	101-104
Divaricatori delicati	100
Divaricatori per spatole cerebrali	202-206
<b>E</b>	
ECHLIN Pinze sgorbie	127
EIF Uncino	169
Elevatore per il setto nasale	107
Elevatori	106-107
Enucleatori	256, 262
<b>F</b>	
FARABEUF Periostotomi	110
FERGUSON-FRAZIER Strumenti per aspirazione	82
FERRIS-SMITH KERRISON Laminotomi	164
FISCH Uncino	170
FIXIT sistema di fissazione cranica	131-138
Forbice per fili d'acciaio e placche Mesh HM	246
Forbici	7-30
Forbici chirurgiche	10-13
Forbici delicate	10, 14-15
Forbici delicate per dissezione	14-15
Forbici MICRO 2000	21, 26
Forbici per dura-madre	29
Forbici per fili d'acciaio e placche Mesh	30
Forbici per legatura	30
Forbici per dissezione	14-18
Forbici per trigemino	29
Forbici per tumori	22
Forbici vascolari	19-20
Forbici micro	20-28, 260
Forchetta da sutura	196

Forchetta per trapianto	262
FRAZIER (FERGUSON) Strumenti per aspirazione	82
FRAZIER Separatore	174
FRAZIER Strumenti per aspirazione	81-82
FRAZIER Uncino per dura-madre e pelle	173
FREER Elevatori	107
FREER Periostotomia	108
Frese	150-151, 272-274
Frese "Flameshape"	273
Frese a pallina	150
Frese a pallina diamantate	272
Frese cilindriche	273
Frese cilindriche diamantate	272
Frese neuro	273
Frese per craniotomia	145
Frese per la dermoabrasione	274
Frese per vertebre	273
FRIEDMANN Pinza sgorbia	119
<b>G</b>	
GALT Trepani cranici	147
GIGLI (OLIVECRONA) Seghe di filo d'acciaio	148
GIGLI Manici	148
GILLIES Pinza chirurgica	34
GILLIES Uncini	173
GREENBERG PAR Forbici delicate per dissezione	14
GRUENWALD Pinze a forma di baionetta	51
<b>H</b>	
HALSEY HM Portaghi	67
HARDY Curette	253
HARDY Dissettori	261
HARDY Enucleatori	262
HARDY Forchetta per trapianto	262
HARTMANN PAPAVERO Divaricatore per specoli	264
HEGAR MAYO HM Portaghi	68
HEGEMANN-DIETHRICH Forbici vascolari	19
HM Forbice per fili d'acciaio e placche Mesh	246
HM Forbici per legatura	30
HM Pinze	32, 35, 52
HM Pinze per tagliare fili e placche	246
HOEN Elevatori	106
HOEN Pinza per il cuoio capelluto	88
HOEN Separatori	174
HOPKINS JOHNS Pinze Bulldog	87
HOPKINS JOHNS Pinza per applicare e togliere	87
HORSLEY Separatore	175
HUDSON Trapano a mano	150
HUNT Pinze da presa per tumori	52



<b>I</b>	
Inseriti lavorativi	145, 271
Interruttore a pedale	275
<b>J</b>	
JACOBSON Coltello per vasi	192
JACOBSON Forchetta da sutura	196
JACOBSON HM Micro portaghi	74
JACOBSON Micro forbice	24
JACOBSON Micro pinze	43
JACOBSON Micro portaghi	74
JACOBSON Sonda bottonuta	189
JACOBSON Uncino	170
JACOBSON-ADSON Micro pinze	40
JAMESON REYNOLDS Forbici per dissezione	18
JANSEN ZAUFAL Pinza sgorbia	123
JOHNS-HOPKINS Pinze Bulldog	87
JOHNS-HOPKINS Pinza per applicare e togliere	87
JULIAN HM Portaghi	70
JULIAN Portaghi	70
<b>K</b>	
KERRISON "DieBlauen" Laminotomi	153-157
KERRISON (FERRIS-SMITH) Laminotomi	164
KERRISON (MICRO) Laminotomi	160-163
KERRISON (SCHLESINGER) Laminotomi	159
KERRISON (SPURLING) Laminotomi	158
KERRISON Laminotomi smontabili	155-157
KEY Periostotomi	111
KEY LISTON Pinza ossivora	127
KILLIAN Elevatore per il setto nasale	107
KLEINERT-KUTZ Pinze sgorbie	119
KLIMA-ROSEGGER Cannule per puntura sternale	81
KOCHER MATHIEU HM Portaghi	71
KOOS Coltelli per vasi	193
KRÄMER Periostotomi	109
KRAYENBÜHL Uncini	169
KUTZ KLEINERT Pinze sgorbie	119
<b>L</b>	
LAHEY-CLINIC Uncino per pelle	173
LAMBOTTE Periostotomi	111
Lame per bisturi	4-6
Lame per cacciavite	241, 245, 250
Laminotomi	153-164
Laminotomi smontabili	155-157
LANDOLT Cucchiaio	254
LANDOLT Curetta	254
LANDOLT CUSHING Specoli	263
LANDOLT ENUCLEATORI	256
LANDOLT Manici per bisturi	6
LANDOLT Pinza divaricatrice per specoli	263

LANDOLT Pinza per afferrare tumori	257
LANDOLT-REULEN Dissettore	255
LANDOLT-REULEN Periostotomo	256
LANDOLT-REULEN Uncino	255
LANDOLT Uncini	255
LANGENBECK Elevatori	106
LANGENBECK HM Portaghi	72
LANGENBECK Periostotomi	112
LEKSELL Pinze sgorbie	125-126
LEMPERT Pinze sgorbie	120
LEYLA Braccio tenditore flessibile	204
LEYLA Divaricatori per spatole cerebrali	202-203
LISTON-KEY Pinza ossivora	127
LISTON LITTAUER Pinza ossivora	128
LISTON RUSKIN Pinze ossivore	128
LITTAUER-LISTON Pinza ossivora	128
Lubrificante per motore	276
LUCAE Uncini per nervi	166
LUER Pinze sgorbie	120
LUER STILLE Pinze sgorbie	124
<b>M</b>	
Manici	148
Manici per bisturi	4-6
Manici per cacciavite	241, 245, 250
MARQUARDT Pinza sgorbia	123
MASEL Placche di copertura per fori	243
MATHIEU HM Portaghi	71
MATHIEU-KOCHER HM Portaghi	71
MATHIEU Portaghi	71
MAYO Forbici chirurgiche	13
MAYO HEGAR HM Portaghi	68
MCINDOE Pinza anatomica	34
MCINDOE Pinze ossivore	128
MCKENZIE Perforatore elicoidale	150
MEHDORN Micro clip vascolari	92
MEHDORN Pinza per applicare	92
METZENBAUM Forbici per dissezione	16
METZENBAUM BABY Forbici delicate per dissezione	15
METZENBAUM-SLIM Forbici per dissezione	17
MICHELE Trepani cranici	147
MICRO 2000 Forbici	21, 26
MICRO 2000 Portaghi	76, 78
MICRO 2000 Pinze	40-42, 48, 54-56
MICRO 2000 pinze per sutura	54-56
MICRO ADSON Pinze delicate	32
Micro ago	197
Micro artigli per tessuti	195
MICRO CASTROVIEJO Micro portaghi	73
Micro clip vascolari	92-98
Micro coltelli lanceolato	195
Micro coltelli per tumori	194



**Alphabetischer Index**  
**Alphabetical Index**  
**Índice alfabético**  
**Index alphabétique**  
**Indice alfabetico**

D05

Micro coltelli per vasi	192-193
Micro cucchiai	197-198
Micro curette	198
Micro dilatatori vascolari	189
Micro forbici	20-28, 260
Micro forbici MICRO 2000	21, 26
Micro forchetta da sutura	196
MICRO KERRISON Laminotomi	160-163
Micro passafilo	196
Micro periostotomi	191-192
Micro pinze	39-50
Micro pinze con morso a cucchiaio	259
Micro pinze titanio	44, 46
Micro portaghi	72-78
Micro portaghi in titanio	77
Micro sonde bottonute	189
Micro strumenti	189-198
Micro uncini	174
MILLESÌ Micro forbice	24
MINI RUSKIN Pinze sgorbie	121
MINI-RYDER HM Portaghi	70
MISKIMON Divaricatore autostatico	102
MOD. AACHEN Spatole cerebrali	200
MOD. KÖLN	
Clip emostatica per cuoio capelluto	142
Motore angolato	144, 270
Motore con accoppiamento INTRA	269
Motore trapano	144
Motori pneumatici	144, 269-270
MÜHLING Periostotomi	108
MÜLLER BIEMER Approssimatori	95-96
<b>N</b>	
NEIVERT HM Portaghi	67
NICOLA Curette	253-254
NICOLA Micro forbice	260
NICOLA Pinza con morso a cucchiaio	258
<b>O</b>	
OLIVECRONA Dissettori	177
OLIVECRONA Forbice per trigemino	29
OLIVECRONA GIGLI Seghe di filo d'acciaio	148
OLIVECRONA Periostotomo	110
OLIVECRONA Spatole cerebrali	201
<b>P</b>	
PAPAVERO-CASPAR Specoli	264
PAPAVERO Scalpello per lamina	257
PAPAVERO-HARTMANN	
Divaricatore per specoli	264
Passafilo	196
PEN Cannule per aspirazione	79-80
PENFIELD Dissettori	178-179
Perforatore piatto	150
Perforatori elicoidali	150, 241, 245, 250

Perforatori a spirale	151-152, 274
Perforatori di Rosen	272
Perforatori per cemento	273
Periostotomi	108-117, 190-191, 256
PETERSEN-SMITH Pinze sgorbie	122
Pinza divaricatrice	263
Pinza per applicare	92-97
Pinze	31-63
Pinze a forma di baionetta	47-53, 60-63
Pinze anatomiche/chirurgiche	32-35
Pinze antiaderenti	57-61
Pinze atraumatiche	36-39
Pinze bipolari	58-63
Pinze bipolari antiaderenti	57-61
Pinze Bulldog	85-87
Pinze Bulldog atraumatiche	85, 87
Pinze Bulldog titanio	85
Pinze di trazione per cranio	149
Pinze da presa	53
Pinze da presa per placche	247
Pinze da presa per viti	247
Pinze delicate, anatomiche e chirurgiche	32-33
Pinze emostatiche	88
Pinze guida-perforatore	147
Pinze HM	32, 35, 52
Pinze micro	39-50
Pinze MICRO 2000	40-42, 48, 54-56
Pinze micro titanio	44, 46
Pinze con morso a cucchiaio	258-259
Pinze ossivore	127-128
Pinze per afferrare	53, 260, 257
Pinze per afferrare tumori	53, 257
Pinze per applicare	92-97
Pinze per applicare clamps Bulldog	87
Pinze per applicare clip cerebrovascolari	221-228
Pinze per applicare e togliere	140-141
Pinze per applicare per clip in titanio	91
Pinze per craniotomia	146
Pinze per gioielliere/orologiaio	39, 58-59
Pinze per il cuoio capelluto	88
Pinze per sutura	54-56
Pinze per tagliare fili e placche	246
Pinze per togliere	87
Pinze per togliere clip cerebrovascolari	229
Pinze piegaplacche	247
Pinze sgorbie	119-127
Pinze vascolari atraumatiche	36-37
Pinze forbice	260
Placche di copertura per fori	235, 243
Placche in titanio	234-239, 242-243, 250
Portaghi	65-78
Portaghi MICRO 2000	76, 78



Portaghi micro	72-78
Portaghi titanio	77
POTTS-SMITH Forbici vascolari	19-20
POTTS-SMITH	
Pinze anatomiche/chirurgiche	34
POTTS-YASARGIL Micro forbice	24
Protezione antispruzzo per la dermoabrasione	274
Punte per perforatore	145
<b>Q</b>	
QUINCKE Cannule per puntura	81
<b>R</b>	
RAIMONDI Pinza per il cuoio capelluto	88
RALK Trapano a mano	152
RANEY	
Clip emostatiche per cuoio capelluto	140-141
RAY Curette	252
REULEN LANDOLT Dissettori	255
REULEN LANDOLT Periostotomo	256
REULEN LANDOLT Uncino	255
REYNOLDS (JAMESON)	
Forbici per dissezione	18
RHOTON Ago	197
RHOTON Cucchiari taglienti	197
RHOTON Dissettori	182
RHOTON Periostotomi	191
RHOTON Sonda bottonuta	189
RHOTON Uncini	171
RIECHERT Fissagi	204
RIECHERT	
Sostegno per spatole cerebrali piatte	204
ROSEGER KLIMA Cannule per puntura	81
RUSKIN Pinze sgorbie	121-122
RUSKIN-LISTON Pinze ossivore	128
RUSKIN-MINI Pinze sgorbie	121
RYDER MINI HM Portaghi	70
<b>S</b>	
SACHS Separatore	175
SAMII Coltelli lanceolati	195
SAMII Coltelli per tumori	194
Scalpello per lamina	257
SCHLESINGER KERRISON Laminotomi	159
SCHMIEDEN (TAYLOR)	
Forbice per dura-madre	29
SEDILLOT Periostotomi	109
Seghe di filo d'acciaio	148
SELECT Pinze delicate	33
SEMB-STILLE Pinze sgorbie	124
SEMKEN Pinze delicate	33
Separatori per dura-madre	174-175
Separatori per nervi	174-175
SHEA Forbici delicate per dissezione	14
SHERMAN STILLE Trapano a mano	151

Sistema di neuro-fissaggio	233-249
Sistemi di fissazione cranica	131-138
SLIM Forbici delicate per dissezione	15
SLIM METZENBAUM Forbici per dissezione	17
SMITH FERRIS KERRISON Laminotomi	164
SMITH POTTS Forbici vascolari	19-20
SMITH POTTS Pinze anatomiche/chirurgiche	34
SMITH-PETERSEN Pinze sgorbie	122
SMITHWICK Uncino simpatectomia	176
Sonde bottonute	189
SÖRENSEN Testieras	134-137
Spatole cerebrali	200-201
Specoli	263-264
SPURLING KERRISON Laminotomi	158
STELLBRINK Pinze sgorbie	119
STILLE Pinza sgorbia	126
STILLE Trapano a mano	151
STILLE-LUER Pinze sgorbie	124
STILLE SEMB Pinze sgorbie	124
STILLE-SHERMAN Trapano a mano	151
STRAIGHT Uncino per pelle	173
STRULLY Forbice per trigemino	29
Strumenti di micro	189-198
Strumenti introduttori	148
Strumenti per adattamento	248
Strumenti per aspirazione e lavaggio	80-83
Strumenti per la trapanazione e craniotomia	143-152
Strumenti per misurare la profondità	248
Supporto di pulizia	276
<b>T</b>	
TAYLOR CUSHING HM	
Pinza a forma di baionetta	51
TAYLOR CUSHING	
Pinze a forma di baionetta	51
TAYLOR SCHMIEDEN	
Forbici per dura-madre	29
Testieras	134-137
Titanio micro pinze	44, 46
Titanio micro portaghi	77
Titanio clips	90
Titanio pinze Bulldog	85
TOENNIS Dissettori	180
TOENNIS HM Portaghi	72
TOENNIS Pinze per afferrare tumori	53
TOENNIS Uncino	174
Trapani	151
Trapani a mano	150-152
Trepano cranico	147
Tubi d'irrigazione	271
Tubi da parete	275
Tubo d'alimentazione	275
TUOHY Cannule per puntura	81

**D05**

**Alphabetischer Index**  
**Alphabetical Index**  
**Índice alfabético**  
**Index alphabétique**  
**Índice alfabético**

<b>U</b>	
Uncini	166-176, 255
Uncini e dissettori	165-184, 255
Uncini per dura-madre	172-173
Uncini per esplorazione	176
Uncini per nervi	166-169
Uncini per pelle	172-173
Uncini per vasi	169
Uncini per galea	142
Uncino simpatectomia	176
<b>UNIVERSAL</b>	
Forbice per fili d'acciaio e placche Mesh	30
<b>UNIVERSAL HM</b>	
Forbice per fili d'acciaio e placche Mesh	30, 246
<b>V</b>	
Viti in titanio	240, 244, 250
VIPAIR - Sistema di motore pneumatico	143-145, 265-276
<b>W</b>	
WAGNER Periostotomi	117
WEITLANER Divaricatori autostatici	101-102
WEITLANER-BECKMANN Divaricatori autostatici	104
WILLIGER Periostotomi	108
WOOD CRILE BABY HM Portaghi	70
WOOD CRILE BABY Portaghi	69
WOOD CRILE HM (DEBAKEY HM) Portaghi	69
WOOD CRILE Portaghi	69
<b>Y</b>	
YASARGIL Artiglie per tessuti	195
YASARGIL Cannule per aspirazione	82
YASARGIL Clip cerebrovascolari	207-220
YASARGIL Clip cerebrovascolare "Mini"	219-220
YASARGIL Clip cerebrovascolare "Standard"	209-218
YASARGIL Coltelli per vasi	193
YASARGIL Dissetto	181
YASARGIL Passafilo	196
YASARGIL Micro forbice	24, 26-28
YASARGIL Micro pinze	47, 49-50
YASARGIL Micro portaghi	74, 78
YASARGIL Periostotomi	191-192
YASARGIL Pinze da presa per tumori	53
YASARGIL Pinze con morso a cucchiaio	258
YASARGIL Pinze per afferrare	260
YASARGIL Pinze per applicare clip cerebrovascolari	221-228
YASARGIL Pinze per togliere clip cerebrovascolari	229
YASARGIL POTTS Micro forbice	24
YASARGIL Uncini per galea	142
<b>Z</b>	
ZAUFAL-JANSEN Pinza sgorbia	123

# MEDICONTAINER CONTAINER System



**D06**

**Numerischer Index**  
**Numerical Index**  
**Indice numérico**  
**Index numérique**  
**Indice numerico**

01.22.10	4	03.50.14	13	05.15.70	21	06.20.62	32
01.22.11	4	03.50.17	13	05.15.71	21	06.20.65	32
01.22.12	4	03.50.64	13	05.15.72	21	06.21.12	32
01.22.15	4	03.50.67	13	05.15.73	21	06.21.13	32
01.22.20	5	03.51.14	13	05.15.74	20	06.21.62	32
01.22.21	5	03.51.17	13	05.15.75	20	06.21.65	32
01.22.25	5	03.51.64	13	05.15.76	20	06.22.12	32
01.22.32	4	03.51.67	13	05.15.77	20	06.22.15	32
01.22.35	4	04.13.12	14	05.15.81	21	06.23.12	32
01.27.03	4	04.24.14	15	05.15.83	21	06.23.15	32
01.27.07	4	04.24.64	15	05.16.68	22	06.30.12	33
01.27.21	6	04.25.14	15	05.16.69	22	06.30.15	33
01.27.25	6	04.25.64	15	05.16.74	22	06.30.22	33
01.27.40	4	04.32.11	15	05.16.75	22	06.30.25	33
01.28.04	5	04.32.14	16	05.18.68	22	06.31.12	33
01.28.14	5	04.32.18	16	05.18.69	22	06.31.15	33
01.28.45	5	04.32.20	16	05.18.70	21	06.31.22	33
01.30.36	6	04.32.61	15	05.18.71	21	06.31.25	33
01.30.37	6	04.32.64	16	05.18.72	21	06.31.32	33
01.30.62	6	04.32.68	16	05.18.73	21	06.34.55	33
01.30.64	6	04.32.70	16	05.18.74	22	06.34.58	33
01.30.65	6	04.33.11	15	05.18.75	22	06.34.60	33
01.30.67	6	04.33.14	16	05.18.81	21	06.35.55	33
01.30.69	6	04.33.18	16	05.18.83	21	06.35.58	33
02.50.45	10	04.33.20	16	05.18.84	23	06.35.60	33
03.02.14	10	04.33.61	15	05.18.85	23	06.40.15	34
03.02.16	10	04.33.64	16	05.18.86	23	06.40.85	34
03.02.64	10	04.33.68	16	05.18.87	23	06.46.18	34
03.02.84	13	04.33.70	16	05.18.89	23	06.46.20	34
03.03.14	10	04.34.14	17	05.18.90	23	06.46.25	34
03.03.16	10	04.34.18	17	05.18.92	23	06.48.18	34
03.03.64	10	04.34.20	17	05.18.93	23	06.48.20	34
03.03.84	13	04.34.64	17	05.18.94	23	06.48.25	34
03.04.14	11	04.34.68	17	05.18.95	23	06.50.15	36
03.04.16	11	04.34.70	17	05.18.96	24	06.50.19	36
03.04.64	11	04.35.14	17	05.18.97	24	06.50.24	36
03.04.84	12	04.35.18	17	05.18.98	24	06.50.30	36
03.05.14	11	04.35.20	17	05.18.99	24	06.51.15	37
03.05.16	11	04.35.64	17	05.19.01	24	06.51.20	37
03.05.64	11	04.35.68	17	05.19.02	25	06.52.15	36
03.05.84	12	04.35.70	17	05.19.10	25	06.52.19	36
03.06.14	11	04.66.12	18	05.19.25	25	06.52.24	36
03.06.16	11	04.66.14	18	05.19.45	25	06.52.30	36
03.06.64	11	04.66.16	18	05.19.60	25	06.54.15	36
03.06.84	12	04.66.18	18	05.21.68	22	06.54.19	36
03.07.14	11	04.67.12	18	05.21.69	22	06.54.24	36
03.07.16	11	04.67.14	18	05.21.74	22	06.54.30	36
03.07.64	11	04.67.16	18	05.21.75	22	06.55.15	36
03.07.84	12	04.67.18	18	06.20.12	32	06.55.19	36



**Numerischer Index  
Numerical Index  
Indice numérico  
Index numérique  
Indice numerico**

06.55.24	36	07.64.03	41	09.83.76	82	10.20.68	69
06.55.30	36	07.64.04	41	09.83.78	82	10.20.70	69
06.60.17	35	07.64.13	41	09.83.80	82	10.20.73	69
06.60.18	35	07.64.14	41	09.83.82	82	10.20.75	69
06.60.68	35	07.64.63	42	09.83.99	83	10.20.76	69
06.60.69	35	07.64.64	42	09.84.13	82	10.20.80	69
06.60.87	35	07.64.73	42	09.84.15	82	10.21.20	70
06.60.88	35	07.64.74	42	09.84.18	82	10.21.23	70
06.62.15	37	07.64.83	42	09.84.22	82	10.21.70	70
06.62.19	37	07.64.84	42	09.84.23	82	10.21.73	70
06.62.24	37	07.64.93	42	09.84.25	82	10.28.63	70
06.64.15	37	07.64.94	42	09.84.28	82	10.28.65	70
06.64.19	37	07.66.12	40	09.84.32	82	10.28.68	70
06.64.24	37	07.66.15	40	09.84.33	82	10.28.70	70
06.70.15	38	07.70.11	43	09.84.35	82	10.28.73	70
06.70.20	38	07.70.15	43	09.84.38	82	11.18.64	71
06.70.24	38	07.70.18	43	09.84.42	82	11.18.67	71
06.72.15	38	07.72.19	41	09.84.43	82	11.18.70	71
06.72.20	38	07.74.15	44	09.84.45	82	11.20.14	71
06.72.24	38	07.74.18	44	09.84.48	82	11.20.17	71
06.74.15	38	07.74.21	44	09.84.52	82	11.20.20	71
06.74.20	38	07.75.20	47	09.99.01	80	11.20.64	71
06.74.24	38	07.75.30	43	09.99.07	80	11.20.67	71
06.90.15	39	07.75.31	43	09.99.08	80	11.20.70	71
06.90.18	39	07.75.32	43	09.99.09	80	11.20.74	71
06.90.21	39	07.75.40	48	09.99.11	80	11.34.66	72
06.92.15	39	07.75.42	48	09.99.12	80	11.34.68	72
06.92.18	39	07.75.43	48	09.99.13	80	11.34.70	72
06.92.21	39	07.76.15	44	10.08.62	67	11.36.66	72
07.26.18	51	07.76.18	44	10.10.63	67	11.36.68	72
07.26.19	51	07.76.21	44	10.14.64	67	11.36.70	72
07.26.68	51	09.70.18	81	10.18.65	68	11.62.14	72
07.27.18	51	09.72.07	81	10.18.68	68	11.62.15	72
07.30.16	51	09.72.08	81	10.18.70	68	11.62.17	72
07.30.19	51	09.72.10	81	10.18.73	68	11.62.18	72
07.31.16	51	09.72.11	81	10.18.74	68	11.62.63	72
07.31.19	51	09.72.12	81	10.18.76	68	11.62.64	73
07.60.03	39	09.72.13	81	10.18.80	68	11.62.67	73
07.60.04	39	09.72.14	81	10.18.85	68	11.62.84	73
07.60.05	39	09.73.12	81	10.18.88	68	11.62.87	73
07.60.07	39	09.73.14	81	10.18.90	68	11.70.22	73
07.60.10	40	09.73.16	81	10.18.93	68	11.70.23	73
07.61.05	40	09.73.92	81	10.20.14	69	11.70.24	73
07.61.06	40	09.73.93	81	10.20.15	69	11.70.25	73
07.61.11	41	09.83.56	82	10.20.18	69	11.74.13	73
07.61.12	41	09.83.58	82	10.20.20	69	11.74.15	73
07.61.14	41	09.83.60	82	10.20.23	69	11.74.23	73
07.63.31	40	09.83.62	82	10.20.64	70	11.74.25	73
07.63.32	40	09.83.73	82	10.20.65	69	11.80.68	74

**D06**

**Numerischer Index**  
**Numerical Index**  
**Indice numérico**  
**Index numérique**  
**Indice numerico**

11.80.71	74	12.18.69	75	13.71.62	54	15.15.38	87
11.82.18	74	12.18.70	76	13.71.70	54	15.15.51	87
11.82.21	74	12.18.71	76	13.71.72	54	15.16.07	87
11.82.68	74	12.18.72	76	13.71.82	55	15.17.07	87
11.82.71	74	12.18.73	76	13.71.83	55	15.19.93	87
11.84.68	74	12.18.74	76	13.71.84	56	16.11.83	88
11.85.68	74	12.18.75	76	13.71.86	56	16.11.84	88
11.86.68	74	12.18.76	75	14.06.84	30	16.11.94	88
11.87.68	74	12.18.77	75	14.06.88	30	16.11.97	88
12.12.40	78	12.18.78	75	14.06.93	30	16.11.98	88
12.12.41	78	12.18.79	75	14.23.12	30	20.20.34	166
12.12.42	78	12.18.80	75	14.23.62	30, 246	20.20.57	166
12.12.43	78	12.18.81	75	14.26.72	246, 248	20.20.59	166
12.12.48	78	12.18.82	75	14.30.13	246	20.22.01	166
12.12.54	75	12.18.83	75	14.30.17	246	20.22.02	166
12.12.55	75	12.18.85	77	15.04.30	85	20.22.03	166
12.12.56	75	12.18.86	77	15.04.31	85	20.22.31	167
12.12.57	75	12.18.87	77	15.04.35	85	20.22.32	167
12.12.59	75	12.18.88	77	15.04.36	85	20.22.36	167
12.12.61	75	12.21.56	75	15.04.40	85	20.22.37	167
12.15.30	78	12.21.57	75	15.04.41	85	20.27.22	172
12.15.31	78	12.21.60	75	15.04.50	85	20.27.23	172
12.15.32	78	12.21.61	75	15.04.51	85	20.27.37	172
12.15.33	78	12.21.66	75	15.05.30	85	20.30.12	173
12.15.50	74	12.21.67	75	15.05.31	85	20.30.19	173
12.15.51	74	12.21.70	75	15.05.35	85	20.30.20	173
12.15.56	75	12.21.71	75	15.05.36	85	20.31.13	173
12.15.57	75	12.21.76	75	15.05.40	85	20.31.15	173
12.15.66	75	12.21.77	75	15.05.41	85	20.64.01	100
12.15.67	75	12.21.78	75	15.05.50	85	20.64.02	100
12.15.70	76	12.21.79	75	15.05.51	85	20.64.03	100
12.15.71	76	12.21.80	75	15.07.30	85	20.64.04	100
12.15.72	76	12.21.81	75	15.07.31	85	20.65.01	100
12.15.73	76	12.21.82	75	15.07.35	85	20.65.02	100
12.15.76	75	12.21.83	75	15.07.36	85	20.65.03	100
12.15.77	75	12.21.95	77	15.07.40	85	20.65.04	100
12.15.78	75	12.21.96	77	15.07.41	85	20.66.01	100
12.15.79	75	12.21.97	77	15.07.50	85	20.66.02	100
12.16.75	77	12.21.98	77	15.07.51	85	20.66.03	100
12.16.76	77	13.70.42	54	15.10.08	86	20.66.04	100
12.16.77	77	13.70.72	56	15.10.12	86	20.67.01	100
12.16.78	77	13.70.74	56	15.10.16	86	20.67.02	100
12.18.56	75	13.71.22	56	15.10.38	86	20.67.03	100
12.18.57	75	13.71.23	56	15.10.51	86	20.67.04	100
12.18.60	75	13.71.42	55	15.11.08	86	24.22.13	101
12.18.61	75	13.71.43	55	15.11.12	86	24.22.14	101
12.18.66	75	13.71.50	54	15.11.16	86	24.22.16	101
12.18.67	75	13.71.52	54	15.11.38	86	24.22.17	101
12.18.68	75	13.71.60	54	15.11.51	86	24.22.20	101



**Numerischer Index**  
**Numerical Index**  
**Indice numérico**  
**Index numérique**  
**Indice numerico**

**D06**

24.22.21	101	26.56.25	111	30.76.29	120	55.15.46	20
24.22.24	101	26.60.35	112	31.04.02	121	55.15.50	19
24.22.25	101	26.62.01	112	31.04.03	121	55.15.51	19
24.22.26	102	26.62.02	112	31.05.02	121	56.50.01	90
24.22.27	102	26.64.06	113	31.05.03	121	56.50.02	90
24.26.70	103	26.64.06P	113	31.06.05	121	56.50.03	90
24.28.01	103	26.64.13	113	31.06.25	122	56.50.04	90
24.28.02	103	26.64.13P	113	31.07.05	121	56.50.11	90
24.28.03	103	26.64.16	113	31.07.25	122	56.50.12	90
24.28.10	102	26.64.16P	113	31.09.03	122	56.50.14	90
24.30.13	104	26.64.26	113	31.09.13	122	56.50.15	91
24.30.14	104	26.64.26P	113	31.09.23	122	56.50.19	91
24.30.16	104	26.64.73	114	31.11.04	123	56.50.25	91
24.30.17	104	26.64.75P	114	31.11.05	123	56.50.29	91
24.30.20	104	26.64.84	115	31.11.13	123	56.50.30	91
24.30.21	104	26.64.86P	115	31.30.23	124	56.50.40	91
26.27.57	106	26.64.94	115	31.30.24	124	56.74.06	95
26.27.65	106	26.64.96P	115	31.31.23	124	56.74.09	95
26.27.70	106	26.65.10	116	31.31.24	124	56.75.09	95
26.29.07	106	26.65.10P	116	31.31.53	124	56.76.09	95
26.29.10	106	26.65.13	116	31.31.57	124	56.77.09	95
26.35.01	108	26.65.13P	116	31.31.83	126	56.78.01	96
26.35.02	107	26.65.19	116	31.51.05	125	56.78.02	96
26.35.03	107	26.65.19P	116	31.51.08	125	56.78.03	96
26.42.03	108	26.65.25	116	31.53.03	125	56.78.04	96
26.42.05	108	26.65.25P	116	31.53.05	125	56.79.00	98
26.42.07	108	26.67.27	117	31.53.08	125	56.79.01	98
26.47.01	108	26.67.27P	117	31.54.03	126	56.80.04	92
26.47.02	108	26.67.33	117	31.54.05	126	56.80.06	92
26.47.11	108	26.67.33P	117	31.54.08	126	56.80.14	92
26.47.12	108	26.67.34	117	31.61.02	127	56.81.04	92
26.47.32	109	26.67.34P	117	31.61.03	127	56.81.06	92
26.47.33	109	26.68.20	114	31.61.04	127	56.85.07	93
26.47.35	109	26.68.20P	114	33.02.15	128	56.85.08	93
26.47.38	109	26.73.09	112	33.56.18	128	56.85.10	93
26.48.01	110	26.73.13	112	33.57.18	128	56.85.11	93
26.48.02	107	26.73.19	112	33.58.18	128	56.85.13	93
26.48.03	110	30.05.14	119	33.59.17	128	56.85.14	93
26.48.04	110	30.52.17	120	33.59.18	128	56.85.16	93
26.50.58	110	30.52.18	120	33.75.27	127	56.85.17	93
26.53.13	110	30.53.18	120	49.50.13	249	56.85.18	93
26.53.23	110	30.54.70	120	49.90.00	276	56.85.19	93
26.54.10	111	30.71.02	119	49.90.04	187	56.85.47	97
26.54.15	111	30.71.03	119	49.97.02	249	56.85.48	97
26.54.20	111	30.76.13	119	55.15.32	19	56.85.50	97
26.54.25	111	30.76.14	119	55.15.34	19	56.85.51	97
26.56.06	111	30.76.17	119	55.15.36	19	56.85.53	97
26.56.12	111	30.76.18	119	55.15.42	20	56.85.54	97
26.56.20	111	30.76.19	120	55.15.44	20	56.85.56	97

**D06**

**Numerischer Index**  
**Numerical Index**  
**Indice numérico**  
**Index numérique**  
**Indice numerico**

<b>56.85.57</b>	97	<b>57.07.22</b>	161	<b>57.09.62</b>	162	<b>57.28.43</b>	156
<b>56.85.58</b>	97	<b>57.07.23</b>	161	<b>57.09.63</b>	162	<b>57.28.44</b>	156
<b>56.85.59</b>	97	<b>57.07.24</b>	161	<b>57.09.64</b>	162	<b>57.28.45</b>	156
<b>56.85.91</b>	93, 97	<b>57.07.25</b>	161	<b>57.09.65</b>	162	<b>57.28.46</b>	156
<b>56.85.93</b>	93, 97	<b>57.07.26</b>	161	<b>57.09.66</b>	162	<b>57.28.51</b>	156
<b>56.85.98</b>	93, 97	<b>57.07.31</b>	161	<b>57.09.67</b>	162	<b>57.28.52</b>	156
<b>56.86.36</b>	93	<b>57.07.32</b>	161	<b>57.09.68</b>	162	<b>57.28.53</b>	156
<b>56.86.37</b>	93	<b>57.07.33</b>	161	<b>57.09.69</b>	162	<b>57.28.54</b>	156
<b>56.86.58</b>	97	<b>57.07.34</b>	161	<b>57.10.05</b>	164	<b>57.28.55</b>	156
<b>56.86.59</b>	97	<b>57.07.35</b>	161	<b>57.10.15</b>	164	<b>57.28.56</b>	156
<b>56.87.05</b>	94	<b>57.07.36</b>	161	<b>57.11.39</b>	163	<b>57.28.61</b>	156
<b>56.87.08</b>	94	<b>57.07.41</b>	160	<b>57.11.40</b>	163	<b>57.28.62</b>	156
<b>56.87.18</b>	94	<b>57.07.42</b>	160	<b>57.11.41</b>	163	<b>57.28.63</b>	156
<b>56.87.35</b>	94	<b>57.07.43</b>	160	<b>57.11.42</b>	163	<b>57.28.64</b>	156
<b>56.87.38</b>	98	<b>57.07.44</b>	160	<b>57.11.51</b>	163	<b>57.28.65</b>	156
<b>56.87.45</b>	94-96	<b>57.07.45</b>	160	<b>57.11.52</b>	163	<b>57.28.66</b>	156
<b>56.87.46</b>	94-96	<b>57.07.46</b>	160	<b>57.11.53</b>	163	<b>57.28.71</b>	157
<b>56.87.49</b>	98	<b>57.07.51</b>	160	<b>57.11.54</b>	163	<b>57.28.72</b>	157
<b>57.01.20</b>	146	<b>57.07.52</b>	160	<b>57.25.16</b>	29	<b>57.28.73</b>	157
<b>57.01.21</b>	146	<b>57.07.53</b>	160	<b>57.25.20</b>	29	<b>57.28.74</b>	157
<b>57.06.43</b>	159	<b>57.07.54</b>	160	<b>57.25.70</b>	29	<b>57.28.75</b>	157
<b>57.06.45</b>	159	<b>57.07.55</b>	160	<b>57.27.91</b>	155	<b>57.28.76</b>	157
<b>57.06.53</b>	158	<b>57.07.56</b>	160	<b>57.27.92</b>	155	<b>57.28.91</b>	157
<b>57.06.55</b>	158	<b>57.07.61</b>	161	<b>57.28.01</b>	155	<b>57.28.92</b>	157
<b>57.06.57</b>	158	<b>57.07.62</b>	161	<b>57.28.02</b>	155	<b>57.28.93</b>	157
<b>57.06.59</b>	158	<b>57.07.63</b>	161	<b>57.28.03</b>	155	<b>57.28.94</b>	157
<b>57.06.63</b>	158	<b>57.07.64</b>	161	<b>57.28.04</b>	155	<b>57.28.95</b>	157
<b>57.06.65</b>	158	<b>57.07.65</b>	161	<b>57.28.05</b>	155	<b>57.28.96</b>	157
<b>57.06.67</b>	158	<b>57.07.66</b>	161	<b>57.28.06</b>	155	<b>57.29.07</b>	53
<b>57.06.69</b>	158	<b>57.07.71</b>	161	<b>57.28.11</b>	155	<b>57.29.10</b>	53
<b>57.06.73</b>	159	<b>57.07.72</b>	161	<b>57.28.12</b>	155	<b>57.29.12</b>	53
<b>57.06.75</b>	159	<b>57.07.73</b>	161	<b>57.28.13</b>	155	<b>57.29.19</b>	200
<b>57.06.83</b>	159	<b>57.07.74</b>	161	<b>57.28.14</b>	155	<b>57.29.20</b>	200
<b>57.06.85</b>	159	<b>57.07.75</b>	161	<b>57.28.15</b>	155	<b>57.31.09</b>	201
<b>57.06.93</b>	159	<b>57.07.76</b>	161	<b>57.28.16</b>	155	<b>57.31.13</b>	201
<b>57.06.95</b>	159	<b>57.07.77</b>	163	<b>57.28.21</b>	155	<b>57.31.18</b>	201
<b>57.07.01</b>	160	<b>57.07.78</b>	163	<b>57.28.22</b>	155	<b>57.31.22</b>	201
<b>57.07.02</b>	160	<b>57.07.79</b>	163	<b>57.28.23</b>	155	<b>57.31.39</b>	201
<b>57.07.03</b>	160	<b>57.07.80</b>	163	<b>57.28.24</b>	155	<b>57.31.43</b>	201
<b>57.07.04</b>	160	<b>57.07.81</b>	163	<b>57.28.25</b>	155	<b>57.31.48</b>	201
<b>57.07.05</b>	160	<b>57.07.82</b>	163	<b>57.28.26</b>	155	<b>57.31.52</b>	201
<b>57.07.06</b>	160	<b>57.09.50</b>	162	<b>57.28.31</b>	155	<b>57.31.59</b>	201
<b>57.07.11</b>	160	<b>57.09.51</b>	162	<b>57.28.32</b>	155	<b>57.31.63</b>	201
<b>57.07.12</b>	160	<b>57.09.52</b>	162	<b>57.28.33</b>	155	<b>57.31.68</b>	201
<b>57.07.13</b>	160	<b>57.09.53</b>	162	<b>57.28.34</b>	155	<b>57.31.72</b>	201
<b>57.07.14</b>	160	<b>57.09.54</b>	162	<b>57.28.35</b>	155	<b>57.32.14</b>	200
<b>57.07.15</b>	160	<b>57.09.55</b>	162	<b>57.28.36</b>	155	<b>57.32.17</b>	200
<b>57.07.16</b>	160	<b>57.09.56</b>	162	<b>57.28.41</b>	156	<b>57.32.20</b>	200
<b>57.07.21</b>	161	<b>57.09.57</b>	162	<b>57.28.42</b>	156	<b>57.33.07</b>	200





**Numerischer Index**  
**Numerical Index**  
**Indice numérico**  
**Index numérique**  
**Indice numerico**

<b>57.33.08</b>	200	<b>57.50.40</b>	176	<b>57.70.14</b>	134	<b>58.30.10</b>	190
<b>57.33.10</b>	200	<b>57.59.01</b>	202	<b>57.70.16</b>	133, 136	<b>58.30.15</b>	181
<b>57.33.11</b>	200	<b>57.59.02</b>	203	<b>57.70.18</b>	136	<b>58.30.16</b>	190
<b>57.33.13</b>	200	<b>57.59.10</b>	202-204	<b>57.70.20</b>	134	<b>58.30.17</b>	190
<b>57.33.14</b>	200	<b>57.59.21</b>	202, 204	<b>57.70.24</b>	134	<b>58.30.18</b>	190
<b>57.33.16</b>	200	<b>57.59.22</b>	203-204	<b>57.70.30</b>	134	<b>58.30.20</b>	189
<b>57.33.17</b>	200	<b>57.59.26</b>	205	<b>57.70.34</b>	134	<b>58.30.23</b>	189
<b>57.33.19</b>	200	<b>57.59.30</b>	202-204	<b>57.70.40</b>	133, 135	<b>58.30.24</b>	189
<b>57.33.22</b>	200	<b>57.59.32</b>	205	<b>57.70.42</b>	135	<b>58.30.25</b>	189
<b>57.34.16</b>	174	<b>57.59.41</b>	206	<b>57.70.44</b>	133, 137	<b>58.30.26</b>	170
<b>57.35.01</b>	174	<b>57.59.42</b>	206	<b>57.70.46</b>	137	<b>58.30.31</b>	169
<b>57.35.02</b>	174	<b>57.59.43</b>	206	<b>57.70.50</b>	133	<b>58.30.32</b>	169
<b>57.35.05</b>	174	<b>57.59.45</b>	206	<b>57.70.60</b>	133	<b>58.30.35</b>	169
<b>57.35.10</b>	175	<b>57.60.00</b>	150	<b>57.70.65</b>	138	<b>58.30.36</b>	169
<b>57.35.19</b>	175	<b>57.60.03</b>	150	<b>57.70.66</b>	138	<b>58.30.41</b>	195
<b>57.35.20</b>	175	<b>57.60.05</b>	150	<b>57.85.01</b>	141	<b>58.30.42</b>	195
<b>57.36.01</b>	177	<b>57.60.09</b>	150	<b>57.85.03A</b>	140	<b>58.30.55</b>	196
<b>57.36.02</b>	177	<b>57.60.14</b>	150	<b>57.85.05</b>	141	<b>58.30.61</b>	196
<b>57.36.03</b>	177	<b>57.60.16</b>	150	<b>57.85.07</b>	140	<b>58.30.62</b>	196
<b>57.36.04</b>	177	<b>57.60.22</b>	150	<b>57.85.10</b>	142	<b>58.30.63</b>	196
<b>57.36.14</b>	177	<b>57.60.34</b>	150	<b>57.85.11</b>	142	<b>58.30.65</b>	196
<b>57.36.25</b>	180	<b>57.60.43</b>	150	<b>57.85.50</b>	142	<b>58.30.91</b>	222
<b>57.36.26</b>	180	<b>57.60.76</b>	150	<b>58.16.45</b>	78	<b>58.30.92</b>	222
<b>57.36.29</b>	180	<b>57.60.95</b>	147	<b>58.16.48</b>	78	<b>58.30.93</b>	222
<b>57.36.51</b>	178	<b>57.61.11</b>	146	<b>58.19.20</b>	26	<b>58.30.94</b>	222
<b>57.36.52</b>	178	<b>57.63.05</b>	147	<b>58.19.21</b>	26	<b>58.31.91</b>	222
<b>57.36.53</b>	178	<b>57.63.08</b>	147	<b>58.19.30</b>	26	<b>58.31.92</b>	222
<b>57.36.54</b>	179	<b>57.63.13</b>	147	<b>58.19.31</b>	26	<b>58.31.93</b>	222
<b>57.36.55</b>	179	<b>57.63.16</b>	147	<b>58.19.40</b>	78	<b>58.31.94</b>	222
<b>57.39.02</b>	81	<b>57.63.19</b>	147	<b>58.19.45</b>	78	<b>58.32.03</b>	170
<b>57.48.03</b>	252	<b>57.64.02</b>	148	<b>58.20.60</b>	48	<b>58.32.04</b>	172
<b>57.48.04</b>	252	<b>57.64.06</b>	148	<b>58.20.64</b>	48	<b>58.32.13</b>	170
<b>57.48.05</b>	252	<b>57.64.30</b>	148	<b>58.20.70</b>	26	<b>58.32.18</b>	170
<b>57.48.13</b>	252	<b>57.64.40</b>	148	<b>58.20.71</b>	26	<b>58.32.21</b>	181
<b>57.48.14</b>	252	<b>57.64.50</b>	148	<b>58.24.15</b>	83	<b>58.32.22</b>	181
<b>57.48.15</b>	252	<b>57.64.60</b>	148	<b>58.24.16</b>	83	<b>58.32.23</b>	181
<b>57.48.23</b>	252	<b>57.64.70</b>	148	<b>58.24.17</b>	83	<b>58.32.32</b>	194
<b>57.48.24</b>	252	<b>57.64.90</b>	148	<b>58.24.18</b>	83	<b>58.32.33</b>	194
<b>57.48.25</b>	252	<b>57.67.01</b>	149	<b>58.24.19</b>	83	<b>58.32.50</b>	198
<b>57.48.33</b>	252	<b>57.67.02</b>	149	<b>58.24.20</b>	83	<b>58.32.51</b>	198
<b>57.48.34</b>	252	<b>57.67.22</b>	151	<b>58.24.21</b>	83	<b>58.32.54</b>	191
<b>57.48.35</b>	252	<b>57.68.02</b>	149	<b>58.24.22</b>	83	<b>58.32.55</b>	191
<b>57.49.10</b>	169	<b>57.68.12</b>	149	<b>58.24.23</b>	83	<b>58.32.56</b>	191
<b>57.49.19</b>	168	<b>57.68.13</b>	149	<b>58.24.24</b>	83	<b>58.32.57</b>	182
<b>57.49.20</b>	168	<b>57.70.00</b>	133-134	<b>58.24.25</b>	83	<b>58.32.58</b>	182
<b>57.49.21</b>	168	<b>57.70.02</b>	133, 136	<b>58.24.26</b>	83	<b>58.32.59</b>	182
<b>57.50.24</b>	168	<b>57.70.06</b>	134, 136	<b>58.24.30</b>	83	<b>58.32.60</b>	182
<b>57.50.25</b>	168	<b>57.70.10</b>	134	<b>58.24.31</b>	83	<b>58.32.61</b>	182
<b>57.50.26</b>	168	<b>57.70.12</b>	133-134	<b>58.30.01</b>	192	<b>58.32.62</b>	197

**D06**

**Numerischer Index**  
**Numerical Index**  
**Indice numérico**  
**Index numérique**  
**Indice numerico**

<b>58.32.63</b>	171	<b>58.35.03</b>	261	<b>58.41.17</b>	217	<b>58.43.70</b>	220
<b>58.32.64</b>	171	<b>58.35.04</b>	261	<b>58.41.20</b>	217	<b>58.43.71</b>	220
<b>58.32.65</b>	171	<b>58.35.05</b>	261	<b>58.41.25</b>	216	<b>58.43.72</b>	220
<b>58.32.66</b>	189	<b>58.35.06</b>	261	<b>58.41.27</b>	216	<b>58.43.73</b>	220
<b>58.32.67</b>	197	<b>58.35.07</b>	262	<b>58.41.30</b>	216	<b>58.44.05</b>	52
<b>58.32.68</b>	197	<b>58.35.08</b>	262	<b>58.41.35</b>	217	<b>58.45.01</b>	260
<b>58.32.91</b>	222	<b>58.35.16</b>	257	<b>58.41.37</b>	217	<b>58.45.10</b>	258
<b>58.32.92</b>	222	<b>58.35.18</b>	258	<b>58.41.45</b>	217	<b>58.45.15</b>	258
<b>58.32.93</b>	222	<b>58.35.19</b>	262	<b>58.41.47</b>	217	<b>58.45.40</b>	260
<b>58.32.94</b>	222	<b>58.35.44</b>	253	<b>58.41.55</b>	218	<b>58.46.20</b>	259
<b>58.33.01</b>	193	<b>58.35.46</b>	253	<b>58.41.57</b>	218	<b>58.46.25</b>	259
<b>58.33.02</b>	193	<b>58.35.48</b>	253	<b>58.41.65</b>	218	<b>58.46.30</b>	259
<b>58.33.05</b>	193	<b>58.35.49</b>	253	<b>58.41.67</b>	218	<b>58.46.40</b>	22
<b>58.33.06</b>	193	<b>58.35.50</b>	254	<b>58.42.03</b>	219	<b>58.46.42</b>	22
<b>58.33.09</b>	198	<b>58.35.70</b>	263	<b>58.42.04</b>	219	<b>58.46.43</b>	22
<b>58.33.17</b>	191	<b>58.35.86</b>	254	<b>58.42.05</b>	219	<b>58.47.01</b>	176
<b>58.33.18</b>	192	<b>58.35.90</b>	263	<b>58.42.06</b>	219	<b>58.47.02</b>	176
<b>58.33.19</b>	192	<b>58.35.91</b>	263	<b>58.42.07</b>	219	<b>58.47.03</b>	176
<b>58.33.22</b>	183	<b>58.35.92</b>	255	<b>58.42.53</b>	219	<b>58.47.04</b>	176
<b>58.33.23</b>	183	<b>58.35.96</b>	254	<b>58.42.55</b>	219	<b>58.47.05</b>	216
<b>58.33.24</b>	183	<b>58.35.97</b>	256	<b>58.42.58</b>	219	<b>58.47.07</b>	216
<b>58.33.25</b>	184	<b>58.35.98</b>	256	<b>58.42.63</b>	219	<b>58.47.10</b>	216
<b>58.33.26</b>	184	<b>58.35.99</b>	263	<b>58.42.65</b>	219	<b>58.47.15</b>	217
<b>58.33.27</b>	184	<b>58.36.02</b>	184	<b>58.43.03</b>	219	<b>58.47.17</b>	217
<b>58.33.41</b>	194	<b>58.36.03</b>	184	<b>58.43.05</b>	219	<b>58.47.20</b>	217
<b>58.33.42</b>	194	<b>58.36.17</b>	255	<b>58.43.06</b>	219	<b>58.47.25</b>	216
<b>58.33.43</b>	194	<b>58.36.20</b>	255	<b>58.43.07</b>	219	<b>58.47.27</b>	216
<b>58.33.44</b>	194	<b>58.36.32</b>	256	<b>58.43.08</b>	219	<b>58.47.30</b>	216
<b>58.33.48</b>	195	<b>58.36.40</b>	264	<b>58.43.09</b>	220	<b>58.47.35</b>	217
<b>58.33.49</b>	195	<b>58.36.41</b>	264	<b>58.43.10</b>	220	<b>58.47.37</b>	217
<b>58.33.65</b>	186	<b>58.36.42</b>	264	<b>58.43.15</b>	219	<b>58.47.45</b>	217
<b>58.33.66</b>	187	<b>58.36.43</b>	264	<b>58.43.16</b>	220	<b>58.47.47</b>	217
<b>58.33.67</b>	186	<b>58.36.44</b>	257	<b>58.43.17</b>	220	<b>58.47.55</b>	218
<b>58.33.68</b>	187	<b>58.36.91</b>	223	<b>58.43.40</b>	220	<b>58.47.57</b>	218
<b>58.33.70</b>	186	<b>58.36.92</b>	223	<b>58.43.41</b>	220	<b>58.47.65</b>	218
<b>58.33.71</b>	187	<b>58.36.93</b>	223	<b>58.43.42</b>	220	<b>58.47.67</b>	218
<b>58.33.72</b>	186	<b>58.36.94</b>	223	<b>58.43.43</b>	220	<b>58.53.50</b>	214
<b>58.33.73</b>	187	<b>58.37.91</b>	223	<b>58.43.48</b>	220	<b>58.53.51</b>	214
<b>58.33.75</b>	186	<b>58.37.92</b>	223	<b>58.43.53</b>	219	<b>58.53.52</b>	214
<b>58.33.76</b>	187	<b>58.37.93</b>	223	<b>58.43.55</b>	219	<b>58.53.53</b>	214
<b>58.33.80</b>	186	<b>58.37.94</b>	223	<b>58.43.57</b>	219	<b>58.53.54</b>	214
<b>58.33.91</b>	222	<b>58.38.91</b>	223	<b>58.43.58</b>	219	<b>58.53.55</b>	214
<b>58.33.92</b>	222	<b>58.38.92</b>	223	<b>58.43.59</b>	219	<b>58.53.56</b>	214
<b>58.33.93</b>	222	<b>58.38.93</b>	223	<b>58.43.61</b>	220	<b>58.53.57</b>	214
<b>58.33.94</b>	222	<b>58.38.94</b>	223	<b>58.43.63</b>	220	<b>58.53.58</b>	214
<b>58.34.91</b>	223	<b>58.41.05</b>	216	<b>58.43.65</b>	219	<b>58.53.60</b>	215
<b>58.34.92</b>	223	<b>58.41.07</b>	216	<b>58.43.67</b>	220	<b>58.53.61</b>	215
<b>58.34.93</b>	223	<b>58.41.10</b>	216	<b>58.43.68</b>	220	<b>58.53.62</b>	215
<b>58.34.94</b>	223	<b>58.41.15</b>	217	<b>58.43.69</b>	220	<b>58.53.63</b>	215



**Numerischer Index  
Numerical Index  
Indice numérico  
Index numérique  
Indice numerico**

<b>58.53.64</b>	215	<b>58.55.20</b>	210	<b>58.56.06</b>	219	<b>58.58.12</b>	214
<b>58.53.65</b>	215	<b>58.55.28</b>	210	<b>58.56.07</b>	219	<b>58.58.15</b>	214
<b>58.53.66</b>	215	<b>58.55.30</b>	210	<b>58.56.53</b>	219	<b>58.58.17</b>	214
<b>58.53.67</b>	215	<b>58.55.32</b>	210	<b>58.56.55</b>	219	<b>58.58.21</b>	214
<b>58.53.68</b>	215	<b>58.55.36</b>	210	<b>58.56.58</b>	219	<b>58.58.25</b>	214
<b>58.53.69</b>	216	<b>58.55.37</b>	211	<b>58.56.63</b>	219	<b>58.58.27</b>	214
<b>58.53.70</b>	216	<b>58.55.38</b>	211	<b>58.56.65</b>	219	<b>58.58.31</b>	214
<b>58.53.71</b>	216	<b>58.55.39</b>	211	<b>58.56.91</b>	228	<b>58.58.37</b>	215
<b>58.53.74</b>	216	<b>58.55.40</b>	213	<b>58.56.92</b>	228	<b>58.58.39</b>	215
<b>58.53.75</b>	216	<b>58.55.41</b>	213	<b>58.56.96</b>	226	<b>58.58.42</b>	215
<b>58.53.76</b>	216	<b>58.55.42</b>	213	<b>58.56.97</b>	227	<b>58.58.45</b>	215
<b>58.53.77</b>	217	<b>58.55.43</b>	211	<b>58.56.98</b>	227	<b>58.58.47</b>	215
<b>58.53.78</b>	217	<b>58.55.44</b>	211	<b>58.56.99</b>	227	<b>58.58.51</b>	215
<b>58.53.79</b>	217	<b>58.55.45</b>	211	<b>58.57.03</b>	219	<b>58.58.55</b>	215
<b>58.53.81</b>	216	<b>58.55.46</b>	211	<b>58.57.05</b>	219	<b>58.58.57</b>	215
<b>58.53.82</b>	216	<b>58.55.47</b>	211	<b>58.57.06</b>	219	<b>58.58.61</b>	215
<b>58.53.83</b>	216	<b>58.55.48</b>	212	<b>58.57.07</b>	219	<b>58.58.65</b>	216
<b>58.53.86</b>	217	<b>58.55.49</b>	212	<b>58.57.08</b>	219	<b>58.58.67</b>	216
<b>58.53.87</b>	217	<b>58.55.50</b>	212	<b>58.57.09</b>	220	<b>58.58.71</b>	216
<b>58.53.88</b>	217	<b>58.55.51</b>	212	<b>58.57.10</b>	220	<b>58.58.98</b>	227
<b>58.53.89</b>	217	<b>58.55.52</b>	212	<b>58.57.15</b>	219	<b>58.58.99</b>	227
<b>58.53.91</b>	218	<b>58.55.55</b>	212	<b>58.57.16</b>	220	<b>58.59.06</b>	211
<b>58.53.92</b>	218	<b>58.55.57</b>	212	<b>58.57.17</b>	220	<b>58.59.09</b>	211
<b>58.53.93</b>	218	<b>58.55.58</b>	209	<b>58.57.40</b>	220	<b>58.59.12</b>	211
<b>58.53.94</b>	218	<b>58.55.60</b>	209	<b>58.57.41</b>	220	<b>58.59.17</b>	211
<b>58.54.08</b>	209	<b>58.55.62</b>	213	<b>58.57.42</b>	220	<b>58.59.20</b>	211
<b>58.54.10</b>	209	<b>58.55.63</b>	213	<b>58.57.43</b>	220	<b>58.59.50</b>	214
<b>58.54.12</b>	209	<b>58.55.64</b>	210	<b>58.57.48</b>	220	<b>58.59.51</b>	214
<b>58.54.16</b>	209	<b>58.55.65</b>	212	<b>58.57.53</b>	219	<b>58.59.52</b>	214
<b>58.54.18</b>	209	<b>58.55.66</b>	210	<b>58.57.55</b>	219	<b>58.59.53</b>	214
<b>58.54.21</b>	209	<b>58.55.67</b>	213	<b>58.57.57</b>	219	<b>58.59.54</b>	214
<b>58.54.26</b>	209	<b>58.55.68</b>	213	<b>58.57.58</b>	219	<b>58.59.55</b>	214
<b>58.54.36</b>	226	<b>58.55.71</b>	210	<b>58.57.59</b>	219	<b>58.59.56</b>	214
<b>58.54.58</b>	209	<b>58.55.72</b>	210	<b>58.57.61</b>	220	<b>58.59.57</b>	214
<b>58.54.60</b>	209	<b>58.55.80</b>	210	<b>58.57.63</b>	220	<b>58.59.58</b>	214
<b>58.54.62</b>	209	<b>58.55.81</b>	210	<b>58.57.65</b>	219	<b>58.59.60</b>	215
<b>58.54.66</b>	209	<b>58.55.86</b>	210	<b>58.57.67</b>	220	<b>58.59.61</b>	215
<b>58.54.67</b>	209	<b>58.55.87</b>	212	<b>58.57.68</b>	220	<b>58.59.62</b>	215
<b>58.54.71</b>	209	<b>58.55.89</b>	212	<b>58.57.69</b>	220	<b>58.59.63</b>	215
<b>58.54.72</b>	209	<b>58.55.90</b>	212	<b>58.57.70</b>	220	<b>58.59.64</b>	215
<b>58.54.96</b>	226	<b>58.55.91</b>	210	<b>58.57.71</b>	220	<b>58.59.65</b>	215
<b>58.54.97</b>	227	<b>58.55.92</b>	211	<b>58.57.72</b>	220	<b>58.59.66</b>	215
<b>58.54.98</b>	227	<b>58.55.93</b>	212	<b>58.57.73</b>	220	<b>58.59.67</b>	215
<b>58.54.99</b>	227	<b>58.55.94</b>	211	<b>58.58.01</b>	225	<b>58.59.68</b>	215
<b>58.55.08</b>	209	<b>58.55.95</b>	211	<b>58.58.02</b>	225	<b>58.59.69</b>	216
<b>58.55.10</b>	209	<b>58.55.96</b>	212	<b>58.58.03</b>	225	<b>58.59.70</b>	216
<b>58.55.12</b>	210	<b>58.56.03</b>	219	<b>58.58.04</b>	225	<b>58.59.71</b>	216
<b>58.55.16</b>	210	<b>58.56.04</b>	219	<b>58.58.07</b>	214	<b>58.59.74</b>	216
<b>58.55.17</b>	210	<b>58.56.05</b>	219	<b>58.58.09</b>	214	<b>58.59.75</b>	216

**D06**

**Numerischer Index**  
**Numerical Index**  
**Indice numérico**  
**Index numérique**  
**Indice numerico**

<b>58.59.76</b>	216	<b>58.60.67</b>	209	<b>58.61.91</b>	210	<b>58.65.21</b>	213
<b>58.59.77</b>	217	<b>58.60.71</b>	209	<b>58.61.92</b>	211	<b>58.65.25</b>	212
<b>58.59.78</b>	217	<b>58.60.72</b>	209	<b>58.61.93</b>	212	<b>58.65.29</b>	213
<b>58.59.79</b>	217	<b>58.61.08</b>	209	<b>58.61.94</b>	211	<b>58.65.31</b>	213
<b>58.59.81</b>	216	<b>58.61.10</b>	209	<b>58.61.95</b>	211	<b>58.65.37</b>	213
<b>58.59.82</b>	216	<b>58.61.12</b>	210	<b>58.61.96</b>	212	<b>58.65.41</b>	213
<b>58.59.83</b>	216	<b>58.61.16</b>	210	<b>58.61.98</b>	227	<b>58.65.49</b>	213
<b>58.59.85</b>	212	<b>58.61.17</b>	210	<b>58.61.99</b>	227	<b>58.66.00</b>	229
<b>58.59.86</b>	217	<b>58.61.20</b>	210	<b>58.63.05</b>	212	<b>58.66.03</b>	229
<b>58.59.87</b>	217	<b>58.61.28</b>	210	<b>58.63.06</b>	211	<b>58.66.06</b>	229
<b>58.59.88</b>	217	<b>58.61.30</b>	210	<b>58.63.07</b>	212	<b>58.66.09</b>	229
<b>58.59.89</b>	217	<b>58.61.32</b>	210	<b>58.63.08</b>	213	<b>59.16.20</b>	27
<b>58.59.91</b>	218	<b>58.61.36</b>	210	<b>58.63.09</b>	211	<b>59.16.21</b>	27
<b>58.59.92</b>	218	<b>58.61.37</b>	211	<b>58.63.10</b>	212	<b>59.18.10</b>	49
<b>58.59.93</b>	218	<b>58.61.38</b>	211	<b>58.63.12</b>	211	<b>59.18.14</b>	49
<b>58.59.94</b>	218	<b>58.61.39</b>	211	<b>58.63.17</b>	211	<b>59.18.16</b>	47
<b>58.59.98</b>	228	<b>58.61.40</b>	213	<b>58.63.20</b>	211	<b>59.19.10</b>	45
<b>58.59.99</b>	228	<b>58.61.41</b>	213	<b>58.63.21</b>	213	<b>59.19.11</b>	45
<b>58.60.00</b>	232	<b>58.61.42</b>	213	<b>58.63.25</b>	212	<b>59.19.12</b>	45
<b>58.60.01</b>	230	<b>58.61.43</b>	211	<b>58.63.29</b>	213	<b>59.19.13</b>	45
<b>58.60.02</b>	231	<b>58.61.44</b>	211	<b>58.63.31</b>	213	<b>59.19.14</b>	45
<b>58.60.03</b>	231	<b>58.61.45</b>	211	<b>58.63.37</b>	213	<b>59.19.15</b>	45
<b>58.60.04</b>	231	<b>58.61.46</b>	211	<b>58.63.41</b>	213	<b>59.19.16</b>	45
<b>58.60.05</b>	232	<b>58.61.47</b>	211	<b>58.63.49</b>	213	<b>59.19.17</b>	45
<b>58.60.08</b>	209	<b>58.61.48</b>	212	<b>58.64.07</b>	214	<b>59.19.18</b>	45
<b>58.60.10</b>	209	<b>58.61.49</b>	212	<b>58.64.09</b>	214	<b>59.19.19</b>	45
<b>58.60.12</b>	209	<b>58.61.50</b>	212	<b>58.64.12</b>	214	<b>59.20.10</b>	49
<b>58.60.16</b>	209	<b>58.61.51</b>	212	<b>58.64.15</b>	214	<b>59.20.14</b>	49
<b>58.60.18</b>	209	<b>58.61.52</b>	212	<b>58.64.17</b>	214	<b>59.20.16</b>	49
<b>58.60.21</b>	209	<b>58.61.55</b>	212	<b>58.64.21</b>	214	<b>59.20.18</b>	49
<b>58.60.26</b>	209	<b>58.61.57</b>	212	<b>58.64.25</b>	214	<b>59.20.20</b>	27
<b>58.60.31</b>	225	<b>58.61.58</b>	209	<b>58.64.27</b>	214	<b>59.20.21</b>	27
<b>58.60.32</b>	225	<b>58.61.60</b>	209	<b>58.64.31</b>	214	<b>59.20.23</b>	27
<b>58.60.33</b>	225	<b>58.61.62</b>	213	<b>58.64.37</b>	215	<b>59.20.30</b>	27
<b>58.60.34</b>	225	<b>58.61.63</b>	213	<b>58.64.39</b>	215	<b>59.20.31</b>	27
<b>58.60.41</b>	225	<b>58.61.64</b>	210	<b>58.64.42</b>	215	<b>59.20.40</b>	78
<b>58.60.42</b>	225	<b>58.61.65</b>	212	<b>58.64.45</b>	215	<b>59.20.45</b>	78
<b>58.60.43</b>	225	<b>58.61.66</b>	210	<b>58.64.47</b>	215	<b>59.23.10</b>	50
<b>58.60.44</b>	225	<b>58.61.67</b>	213	<b>58.64.51</b>	215	<b>59.23.14</b>	50
<b>58.60.45</b>	221	<b>58.61.68</b>	213	<b>58.64.55</b>	215	<b>59.23.20</b>	28
<b>58.60.46</b>	221	<b>58.61.71</b>	210	<b>58.64.57</b>	215	<b>59.23.21</b>	28
<b>58.60.51</b>	225	<b>58.61.72</b>	210	<b>58.64.61</b>	215	<b>59.23.30</b>	28
<b>58.60.52</b>	225	<b>58.61.80</b>	210	<b>58.64.65</b>	216	<b>59.23.31</b>	28
<b>58.60.53</b>	225	<b>58.61.81</b>	210	<b>58.64.67</b>	216	<b>59.23.40</b>	28
<b>58.60.54</b>	225	<b>58.61.85</b>	212	<b>58.64.71</b>	216	<b>59.23.41</b>	28
<b>58.60.58</b>	209	<b>58.61.86</b>	210	<b>58.65.05</b>	212	<b>59.23.42</b>	78
<b>58.60.60</b>	209	<b>58.61.87</b>	212	<b>58.65.07</b>	212	<b>59.23.45</b>	78
<b>58.60.62</b>	209	<b>58.61.89</b>	212	<b>58.65.08</b>	213	<b>59.24.10</b>	49
<b>58.60.66</b>	209	<b>58.61.90</b>	212	<b>58.65.10</b>	212	<b>59.24.14</b>	49



**Numerischer Index  
Numerical Index  
Indice numérico  
Index numérique  
Indice numerico**

<b>59.44.03</b>	52	<b>68.85.03A</b>	240	<b>68.87.74</b>	234	<b>76.51.21</b>	152
<b>59.44.05</b>	52	<b>68.85.04A</b>	240	<b>68.87.75</b>	234	<b>76.69.15</b>	152
<b>59.44.13</b>	52	<b>68.85.05A</b>	240	<b>68.87.77</b>	235	<b>76.69.20</b>	152
<b>59.44.15</b>	52	<b>68.85.24A</b>	240	<b>68.93.00A</b>	244	<b>76.69.25</b>	152
<b>59.44.43</b>	53	<b>68.85.26A</b>	240	<b>68.93.05A</b>	244	<b>76.69.30</b>	152
<b>59.44.45</b>	53	<b>68.85.43A</b>	240	<b>68.93.12</b>	242	<b>76.69.32</b>	152
<b>59.44.50</b>	50	<b>68.85.44A</b>	240	<b>68.93.20</b>	242	<b>76.69.35</b>	152
<b>59.44.73</b>	52	<b>68.85.45A</b>	240	<b>68.93.23A</b>	244	<b>76.69.40</b>	152
<b>59.44.75</b>	52	<b>68.85.64A</b>	240	<b>68.93.24A</b>	244	<b>76.69.45</b>	152
<b>59.45.15</b>	46	<b>68.85.66A</b>	240	<b>68.93.34A</b>	244	<b>76.69.50</b>	152
<b>59.45.18</b>	46	<b>68.85.73A</b>	240	<b>68.93.49</b>	242	<b>76.69.60</b>	152
<b>59.45.21</b>	46	<b>68.85.74A</b>	240	<b>68.93.50</b>	242	<b>88.00.20</b>	64
<b>59.46.15</b>	46	<b>68.85.75A</b>	240	<b>68.93.51</b>	243	<b>88.00.21</b>	64
<b>59.46.18</b>	46	<b>68.85.83A</b>	240	<b>68.93.52</b>	242	<b>88.00.22</b>	64
<b>59.46.21</b>	46	<b>68.85.84A</b>	240	<b>68.93.53</b>	243	<b>88.00.23</b>	64
<b>59.47.15</b>	46	<b>68.85.85A</b>	240	<b>68.93.54</b>	243	<b>88.00.24</b>	64
<b>59.47.18</b>	46	<b>68.85.98S</b>	250	<b>68.93.59</b>	242	<b>88.00.27</b>	64
<b>59.47.21</b>	46	<b>68.85.99S</b>	250	<b>68.93.60</b>	243	<b>88.00.40</b>	64
<b>59.48.15</b>	46	<b>68.86.11</b>	235	<b>68.93.62</b>	243	<b>88.07.02</b>	58
<b>59.48.18</b>	46	<b>68.86.12</b>	235	<b>68.93.75</b>	242	<b>88.07.03</b>	58
<b>59.48.21</b>	46	<b>68.86.13</b>	235	<b>69.02.40</b>	248	<b>88.07.07</b>	58
<b>59.49.15</b>	47	<b>68.86.14</b>	235	<b>75.23.16</b>	241, 248	<b>88.07.08</b>	58
<b>59.49.18</b>	47	<b>68.86.60</b>	235	<b>75.23.19</b>	241, 245, 248, 250	<b>88.07.12</b>	58
<b>59.49.21</b>	47	<b>68.86.61</b>	235	<b>75.23.41</b>	241, 245, 248	<b>88.07.13</b>	58
<b>63.69.96</b>	276	<b>68.86.62</b>	235	<b>75.23.49</b>	241, 248	<b>88.07.14</b>	58
<b>66.54.10</b>	107	<b>68.86.63</b>	235	<b>75.23.50</b>	241, 245, 248, 250	<b>88.07.15</b>	58
<b>68.76.06</b>	247	<b>68.86.88</b>	236	<b>75.23.52</b>	241, 245, 248, 250	<b>88.07.20</b>	59
<b>68.76.31</b>	241, 245, 248, 250	<b>68.86.90</b>	236	<b>75.23.78A</b>	241, 245, 248, 250	<b>88.07.23</b>	59
<b>68.76.32</b>	241, 248	<b>68.86.91</b>	237	<b>76.50.00</b>	151	<b>88.07.56</b>	59
<b>68.76.41</b>	247	<b>68.86.92</b>	237	<b>76.50.01</b>	151	<b>88.07.57</b>	59
<b>68.76.44</b>	248	<b>68.86.93</b>	237	<b>76.50.10</b>	151	<b>88.07.58</b>	59
<b>68.76.52</b>	247	<b>68.86.94</b>	237	<b>76.50.11</b>	151	<b>88.07.81</b>	58
<b>68.76.53</b>	247	<b>68.87.00</b>	238	<b>76.50.12</b>	151	<b>88.07.82</b>	58
<b>68.76.54</b>	247, 248	<b>68.87.01</b>	238	<b>76.50.13</b>	151	<b>88.07.83</b>	58
<b>68.76.56</b>	248	<b>68.87.02</b>	234	<b>76.50.14</b>	151	<b>88.07.91</b>	59
<b>68.83.03A</b>	240	<b>68.87.03</b>	234	<b>76.50.15</b>	151	<b>88.07.92</b>	59
<b>68.83.04A</b>	240	<b>68.87.07</b>	234	<b>76.50.16</b>	151	<b>88.07.93</b>	59
<b>68.83.05A</b>	240	<b>68.87.14</b>	234	<b>76.50.17</b>	151	<b>88.08.01</b>	60
<b>68.83.34A</b>	240	<b>68.87.27</b>	239	<b>76.50.18</b>	151	<b>88.08.02</b>	60
<b>68.83.36A</b>	240	<b>68.87.28</b>	239	<b>76.50.19</b>	151	<b>88.08.03</b>	60
<b>68.83.53A</b>	240	<b>68.87.29</b>	239	<b>76.50.30</b>	151	<b>88.08.04</b>	60
<b>68.83.54A</b>	240	<b>68.87.30</b>	239	<b>76.50.31</b>	151	<b>88.08.05</b>	60
<b>68.83.55A</b>	240	<b>68.87.34</b>	234	<b>76.50.80</b>	152	<b>88.08.06</b>	60
<b>68.83.73A</b>	240	<b>68.87.44</b>	234	<b>76.50.81</b>	152	<b>88.08.07</b>	60
<b>68.83.74A</b>	240	<b>68.87.46</b>	234	<b>76.51.20</b>	152	<b>88.08.08</b>	60
<b>68.83.75A</b>	240	<b>68.87.59</b>	234			<b>88.08.09</b>	60
<b>68.83.84A</b>	240	<b>68.87.70</b>	234			<b>88.08.10</b>	60
<b>68.83.86A</b>	240	<b>68.87.72</b>	234			<b>88.08.11</b>	60
						<b>88.08.12</b>	60

**D06**

**Numerischer Index**  
**Numerical Index**  
**Indice numérico**  
**Index numérique**  
**Indice numerico**

<b>88.08.13</b>	60	<b>93.00.44</b>	271	<b>93.02.35</b>	273	<b>93.06.01</b>	272
<b>88.08.14</b>	60	<b>93.00.46</b>	271	<b>93.02.37</b>	273	<b>93.06.03</b>	272
<b>88.08.15</b>	60	<b>93.00.48</b>	271	<b>93.02.39</b>	273	<b>93.06.07</b>	272
<b>88.08.71</b>	61	<b>93.00.50</b>	271	<b>93.02.41</b>	273	<b>93.06.08</b>	274
<b>88.08.72</b>	61	<b>93.00.52</b>	271	<b>93.02.43</b>	273	<b>93.06.09</b>	272
<b>88.08.73</b>	61	<b>93.00.54</b>	271	<b>93.02.45</b>	272	<b>93.06.11</b>	272
<b>88.08.76</b>	61	<b>93.00.55</b>	271	<b>93.02.47</b>	274	<b>93.06.13</b>	272
<b>88.08.77</b>	61	<b>93.00.56</b>	271	<b>93.02.49</b>	274	<b>93.06.30</b>	273
<b>88.08.81</b>	61	<b>93.00.60</b>	274	<b>93.02.52</b>	272	<b>93.07.03</b>	272
<b>88.08.82</b>	61	<b>93.00.70</b>	271	<b>93.02.54</b>	272	<b>93.07.05</b>	272
<b>88.08.91</b>	61	<b>93.00.72</b>	271	<b>93.02.66</b>	272	<b>93.07.07</b>	272
<b>88.08.92</b>	61	<b>93.00.74</b>	271	<b>93.02.68</b>	272	<b>93.07.08</b>	272
<b>88.08.93</b>	61	<b>93.00.76</b>	271	<b>93.03.01</b>	272	<b>93.07.09</b>	272
<b>88.12.05</b>	63	<b>93.00.78</b>	271	<b>93.03.03</b>	272	<b>203.02.14</b>	10
<b>88.12.06</b>	63	<b>93.00.80</b>	276	<b>93.03.05</b>	272	<b>203.02.16</b>	10
<b>88.12.07</b>	63	<b>93.00.83</b>	276	<b>93.03.07</b>	272	<b>203.03.14</b>	10
<b>88.12.08</b>	63	<b>93.00.85</b>	276	<b>93.03.08</b>	272	<b>203.03.16</b>	10
<b>88.17.05</b>	62	<b>93.01.01</b>	272	<b>93.03.09</b>	272	<b>203.04.14</b>	11
<b>88.17.06</b>	62	<b>93.01.03</b>	272	<b>93.03.10</b>	272	<b>203.05.14</b>	11
<b>88.17.07</b>	62	<b>93.01.05</b>	272	<b>93.03.11</b>	272	<b>203.06.14</b>	11
<b>88.17.08</b>	62	<b>93.01.07</b>	272	<b>93.03.13</b>	272	<b>203.06.16</b>	11
<b>88.20.05</b>	62	<b>93.01.09</b>	272	<b>93.03.15</b>	272	<b>203.07.14</b>	11
<b>88.20.06</b>	62	<b>93.01.11</b>	272	<b>93.03.17</b>	272	<b>203.50.14</b>	13
<b>88.20.07</b>	62	<b>93.01.13</b>	272	<b>93.03.19</b>	272	<b>203.50.17</b>	13
<b>88.20.08</b>	62	<b>93.01.15</b>	145	<b>93.03.20</b>	272	<b>203.50.64</b>	13
<b>88.23.03</b>	63	<b>93.01.17</b>	274	<b>93.03.21</b>	273	<b>203.50.67</b>	13
<b>88.23.07</b>	63	<b>93.01.19</b>	274	<b>93.03.22</b>	273	<b>203.51.14</b>	13
<b>88.23.12</b>	63	<b>93.01.20</b>	272	<b>93.03.23</b>	273	<b>203.51.17</b>	13
<b>88.24.03</b>	63	<b>93.01.22</b>	272	<b>93.03.35</b>	273	<b>203.51.64</b>	13
<b>88.24.07</b>	63	<b>93.01.23</b>	272	<b>93.03.37</b>	145	<b>203.51.67</b>	13
<b>88.24.12</b>	63	<b>93.02.01</b>	272	<b>93.03.38</b>	145	<b>204.13.12</b>	14
<b>88.70.05</b>	63	<b>93.02.03</b>	272	<b>93.03.40</b>	274	<b>204.13.62</b>	14
<b>88.70.06</b>	63	<b>93.02.05</b>	272	<b>93.03.50</b>	272	<b>204.24.14</b>	15
<b>88.70.16</b>	63	<b>93.02.07</b>	272	<b>93.03.66</b>	272	<b>204.24.64</b>	15
<b>88.70.38</b>	62	<b>93.02.09</b>	272	<b>93.03.68</b>	272	<b>204.25.14</b>	15
<b>88.70.39</b>	62	<b>93.02.11</b>	272	<b>93.04.00</b>	145	<b>204.25.64</b>	15
<b>93.00.00</b>	275	<b>93.02.13</b>	272	<b>93.04.01</b>	272	<b>204.32.11</b>	15
<b>93.00.02</b>	275	<b>93.02.17</b>	272	<b>93.04.03</b>	272	<b>204.32.14</b>	16
<b>93.00.04</b>	275	<b>93.02.19</b>	272	<b>93.04.05</b>	145	<b>204.32.18</b>	16
<b>93.00.10</b>	275	<b>93.02.20</b>	274	<b>93.04.07</b>	272	<b>204.32.20</b>	16
<b>93.00.15</b>	275	<b>93.02.21</b>	272	<b>93.04.09</b>	272	<b>204.32.61</b>	15
<b>93.00.20</b>	144, 270	<b>93.02.22</b>	274	<b>93.04.10</b>	145	<b>204.32.64</b>	16
<b>93.00.22</b>	269	<b>93.02.23</b>	272	<b>93.04.21</b>	272	<b>204.32.68</b>	16
<b>93.00.25</b>	144	<b>93.02.24</b>	274	<b>93.04.23</b>	272	<b>204.32.70</b>	16
<b>93.00.30</b>	145	<b>93.02.25</b>	272	<b>93.05.03</b>	272	<b>204.33.11</b>	15
<b>93.00.32</b>	145	<b>93.02.30</b>	272	<b>93.05.07</b>	272	<b>204.33.14</b>	16
<b>93.00.34</b>	145	<b>93.02.31</b>	273	<b>93.05.09</b>	272	<b>204.33.18</b>	16
<b>93.00.40</b>	271	<b>93.02.32</b>	273	<b>93.05.11</b>	272	<b>204.33.20</b>	16
<b>93.00.42</b>	271	<b>93.02.33</b>	273	<b>93.05.13</b>	272	<b>204.33.61</b>	15



**Numerischer Index**  
**Numerical Index**  
**Indice numérico**  
**Index numérique**  
**Indice numerico**



204.33.64	16	224.13.62	14
204.33.68	16	224.67.66	18
204.33.70	16	224.67.68	18
204.34.14	17	225.15.32	19
204.34.18	17	225.15.34	19
204.34.20	17	225.15.36	19
204.34.64	17	225.15.42	20
204.34.68	17	225.15.44	20
204.34.70	17	225.15.46	20
204.35.14	17	225.19.25	25
204.35.18	17	225.19.45	25
204.35.20	17	225.19.60	25
204.35.64	17	255.15.32	19
204.35.68	17	255.15.34	19
204.35.70	17	255.15.36	19
204.67.12	18	255.15.42	20
204.67.16	18	255.15.44	20
204.67.18	18	255.15.46	20
205.15.74	20	909.81.01	80
205.18.70	21		
205.18.71	21		
213.02.14	10		
213.03.14	10		
213.04.14	11		
213.05.14	11		
213.06.14	11		
213.07.14	11		
213.50.14	13		
213.50.17	13		
213.51.14	13		
213.51.17	13		
214.13.12	14		
214.32.11	15		
214.32.14	16		
214.32.18	16		
214.32.20	16		
214.33.11	15		
214.33.14	16		
214.33.18	16		
214.33.20	16		
214.34.14	17		
214.34.18	17		
214.34.20	17		
214.35.14	17		
214.35.18	17		
214.35.20	17		
214.67.12	18		
214.67.16	18		
214.67.18	18		



||| CMF

||| SURGICAL

||| NEURO+SPINE



**Medicon eG**

Gänsäcker 15  
D-78532 Tuttlingen

P. O. Box 44 55  
D-78509 Tuttlingen

Tel.: +49 (0) 74 62 / 20 09-0  
Fax: +49 (0) 74 62 / 20 09-50

E-Mail: [sales@medicon.de](mailto:sales@medicon.de)  
Internet: [www.medicon.de](http://www.medicon.de)

Germany

450.00.58

**medicon**<sup>®</sup>

||| NEURO+SPINE

