

MEDICON eG · GERMANY · 47° 57' 31.4" N · 8° 46' 58.6" E

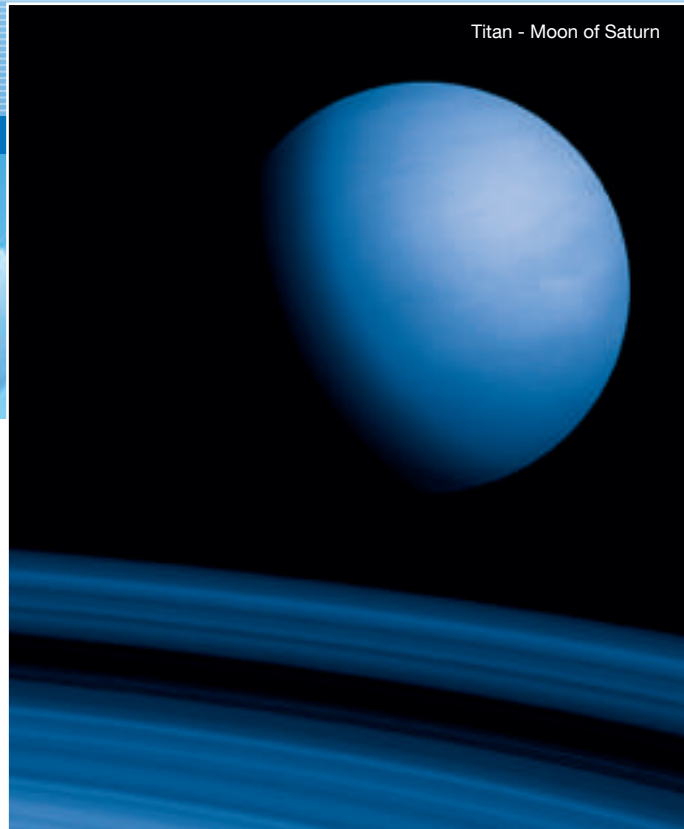

TITAN

Titan-Instrumente für die Herz- und Gefäßchirurgie
Titanium Instruments for Cardiac and Vascular Surgery
Instrumentos de titanio para la cirugía cardíaca y vascular
Instruments en titane pour la chirurgie cardiaque et vasculaire
Strumenti in titanio per la chirurgia cardiaca e vascolare

medicon[®]



Not all products illustrated in this documentation are available for sale in all countries.
Please contact your local distributor for more information.

Modelländerungen vorbehalten
Patterns are subject to change
Salvo modificaciones
Tous droits réservés des changements de modèle
Ci riserviamo la facoltà di cambiamenti nei modelli

Für Druckfehler übernehmen wir keinerlei Haftung
We are not liable for misprints
Declinamos toda responsabilidad por los errores de impresión que pueda contener este documento
Nous déclinons toute responsabilité en cas d'erreurs d'impression
Non ci assumiamo nessuna responsabilità per eventuali errori di stampa

Gedruckt in Deutschland
Printed in Germany
Impreso en Alemania
Imprimé en Allemagne
Stampato in Germania
Trykket i Tyskland

© Copyright 11/2015, MEDICON eG, Tuttlingen, Germany

Mikro-Scheren
Micro Scissors
Micro tijeras
Micro ciseaux
Micro forbici



15 cm – 6"
05.16.68



18 cm – 7 1/8"
05.18.68



21 cm – 8 1/4"
05.21.68



15 cm – 6"
05.16.69



18 cm – 7 1/8"
05.18.69



21 cm – 8 1/4"
05.21.69



15 cm – 6"
05.16.74



18 cm – 7 1/8"
05.18.74



21 cm – 8 1/4"
05.21.74



8 mm



15 cm – 6"
05.16.75



18 cm – 7 1/8"
05.18.75



21 cm – 8 1/4"
05.21.75



Rundgriff
 Round handle
 Mango redondo
 Manche rond
 Manico rotondo



spitz
 sharp
 aguda
 pointu
 acuta



Mikro-Scheren und Feine Pinzetten
Micro Scissors and Delicate Forceps
Micro tijeras y Pinzas finas
Micro ciseaux et Pincés délicates
Micro forbici e Pinze delicate



"HM"



25°

18,5 cm – 7¼"

05.20.25



45°

18,5 cm – 7¼"

05.20.45



60°

18,5 cm – 7¼"

05.20.60

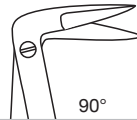

90°

17,5 cm – 7"

05.20.90

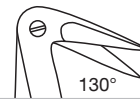

130°

17,5 cm – 7"

05.20.95



Feine Pinzetten
 Delicate forceps
 Pinzas finas
 Pincés délicates
 Pinze delicate



Micro-Adson



12 cm – 4¾"

06.22.22



Micro-Adson

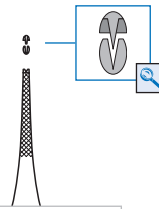

12 cm – 4¾"

06.23.22

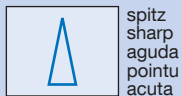

Anatomische und chirurgische Pinzetten
 Dressing and Tissue Forceps
 Pinzas anatómicas y quirúrgicas
 Pincas anatomiques et chirurgicales
 Pinze anatomiche e chirurgiche



Gerald

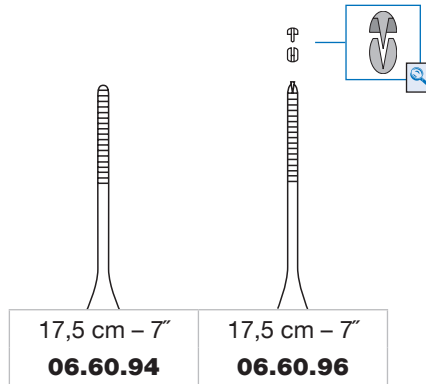

Resano

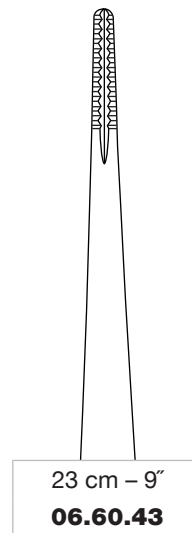

Vergrößerung
 Magnification
 Engrandecimiento
 Agrandissement
 Ingrandimento



Atraumatische Pinzetten
Atraumatic Forceps
Pinzas atraumáticas
Pinces atraumatiques
Pinze atraumatiche



DeBakey "AT"

1,0 mm

1,0 mm

1,0 mm



15 cm – 6"
06.70.15

20 cm – 8"
06.70.20

24 cm – 9½"
06.70.24



DeBakey "AT"

1,5 mm

1,5 mm

1,5 mm

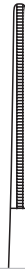

15 cm – 6"
06.72.15

20 cm – 8"
06.72.20

24 cm – 9½"
06.72.24

"AT"

 Atraumatische Riefung
 Atraumatic serration
 Estrías atraumáticas
 Striure atraumatique
 Zigrinatura atraumatica

Atraumatische Pinzetten
Atraumatic Forceps
Pinzas atraumáticas
Pinces atraumatiques
Pinze atraumatiche

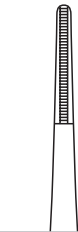

2,0 mm



15 cm – 6"
06.74.15

2,0 mm

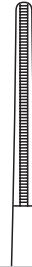

20 cm – 8"
06.74.20

2,0 mm

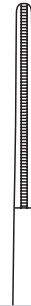

24 cm – 9½"
06.74.24

DeBakey "AT"



2,8 mm



15 cm – 6"
06.76.15

2,8 mm

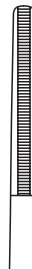

20 cm – 8"
06.76.20

2,8 mm

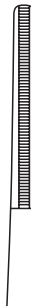

24 cm – 9½"
06.76.24

DeBakey "AT"

"AT"



Atraumatische Riefung
 Atraumatic serration
 Estriás atraumáticas
 Striure atraumatique
 Zigrinatura atraumatica



Atraumatische Pinzetten
Atraumatic Forceps
Pinzas atraumáticas
Pinces atraumatiques
Pinze atraumatiche



DeBakey "AT"

1,2 mm

1,2 mm

1,2 mm

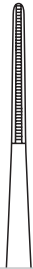
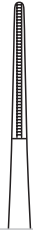
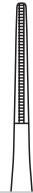

15 cm – 6"
06.90.15

18 cm – 7 1/8"
06.90.18

21 cm – 8 1/4"
06.90.21



DeBakey "AT"

1,2 mm

1,2 mm

1,2 mm

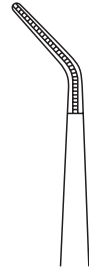
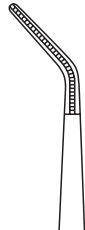
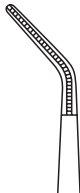

15 cm – 6"
06.91.15

18 cm – 7 1/8"
06.91.18

21 cm – 8 1/4"
06.91.21



Atraumatische Riefung
Atraumatic serration
Estrías atraumáticas
Striure atraumatique
Zigrinatura atraumatica

Atraumatische Pinzetten
Atraumatic Forceps
Pinzas atraumáticas
Pinces atraumatiques
Pinze atraumatiche



DeBakey "AT"

1,8 mm

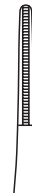

15 cm – 6"
06.92.15

1,8 mm

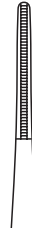

18 cm – 7 1/8"
06.92.18

1,8 mm



21 cm – 8 1/4"
06.92.21



DeBakey "AT"

1,8 mm

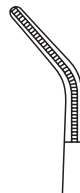

15 cm – 6"
06.93.15

1,8 mm



18 cm – 7 1/8"
06.93.18

1,8 mm

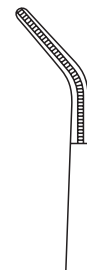

21 cm – 8 1/4"
06.93.21

"AT"



Atraumatische Riefung
 Atraumatic serration
 Estriás atraumáticas
 Striure atraumatique
 Zigrinatura atraumatica



Mikro-Pinzetten
Micro Forceps
Micro pinzas
Micro pincers
Micro pinze



8 mm

0,4 mm

0,4 mm

0,4 mm



15 cm – 6"
07.74.15

18 cm – 7 1/8"
07.74.18

21 cm – 8 1/4"
07.74.21



8 mm

0,8 mm

0,8 mm

0,8 mm



15 cm – 6"
07.76.15

18 cm – 7 1/8"
07.76.18

21 cm – 8 1/4"
07.76.21



spitz
sharp
aguda
pointu
acuta



stumpf
blunt
roma
mousse
smussa



Rundgriff
Round handle
Mango redondo
Manche rond
Manico rotondo

Mikro-Pinzetten
Micro Forceps
Micro pinzas
Micro pincers
Micro pinze



8 mm

0,4 mm



15 cm – 6"
07.75.15



0,4 mm



18 cm – 7 1/8"
07.75.18



0,4 mm



21 cm – 8 1/4"
07.75.21



8 mm

0,8 mm



15 cm – 6"
07.77.15



0,8 mm



18 cm – 7 1/8"
07.77.18



0,8 mm



21 cm – 8 1/4"
07.77.21



spitz
 sharp
 aguda
 pointu
 acuta



stumpf
 blunt
 roma
 mousse
 smussa

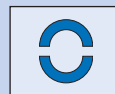

Rundgriff
 Round handle
 Mango redondo
 Manche rond
 Manico rotondo



Mikro-Pinzetten
Micro Forceps
Micro pinzas
Micro pinces
Micro pinze



Ø 1,0 mm

Ø 1,0 mm

Ø 1,0 mm

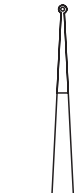

15 cm – 6"
59.45.15

18 cm – 7 1/8"
59.45.18

21 cm – 8 1/4"
59.45.21



Ø 2,0 mm

Ø 2,0 mm

Ø 2,0 mm



15 cm – 6"
59.46.15

18 cm – 7 1/8"
59.46.18

21 cm – 8 1/4"
59.46.21



Vergrößerung
Magnification
Engrandecimiento
Agrandissement
Ingrandimento



Ringe gerieft
Tips serrated
Anillos estriados
Anneaux striés
Anelli zigrinati



Rundgriff
Round handle
Mango redondo
Manche rond
Manico rotondo

Mikro-Pinzetten
Micro Forceps
Micro pinzas
Micro pincers
Micro pinze



Ø 1,0 mm

Ø 1,0 mm

Ø 1,0 mm



15 cm - 6"

59.47.15

18 cm - 7 1/8"

59.47.18

21 cm - 8 1/4"

59.47.21



Ø 2,0 mm

Ø 2,0 mm

Ø 2,0 mm



15 cm - 6"

59.48.15

18 cm - 7 1/8"

59.48.18

21 cm - 8 1/4"

59.48.21



Vergrößerung
 Magnification
 Engrandecimiento
 Agrandissement
 Ingrandimento

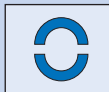

Rundgriff
 Round handle
 Mango redondo
 Manche rond
 Manico rotondo



Beschichtung mit Diamantstaub
 Coating with diamond dust
 Recubierto con polvo de diamante
 Revêtement avec de poussière de diamant
 Rivestito con polvere di diamante



“HM”

Nadelhalter mit Hartmetalleinlagen
Needle holders with tungsten carbide inserts
Porta-agujas con bocas revestidas con plaquitas de carburo de tungsteno
Porte-aiguilles avec mors en carbure de tungstène
Portaghi con placchette in carburo di tungsteno

N 0,5 mm

normal
regular
normal
normale
normale

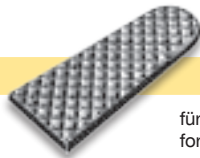

für Nadeln und Nahtmaterial bis Stärke 4-0
 for needles and sutures up to size 4-0
 para agujas y material de sutura hasta el espesor de 4-0
 pour aiguilles et matériel à suture jusqu'à une épaisseur de 4-0
 per aghi e materiale per sutura fino ad uno spessore di 4-0

F 0,4 mm

fein
fine
fine
fine
fine

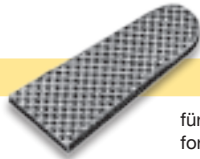

für feine Nadeln und Nahtmaterial in der Stärke 5-0 und 6-0
 for delicate needles and sutures sizes 5-0 and 6-0
 para agujas finas y material de sutura para espesores 5-0 y 6-0
 pour aiguilles fines et matériel à suture d'une épaisseur de 5-0 et 6-0
 per aghi fini e materiale per sutura fino ad uno spessore di 5-0 e 6-0

EF 0,3 mm

extra-fein
extra-fine
extra-fino
extra-fine
extra-fine

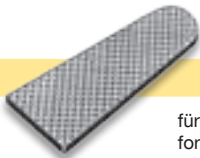

für Mikro-Nadeln und Nahtmaterial bis Stärke 10-0
 for micro-needles and sutures up to size 10-0
 para micro-agujas y material de sutura hasta el espesor de 10-0
 pour micro-aiguilles et matériel à suture jusqu'à une épaisseur de 10-0
 per aghi micro e materiale per sutura fino ad uno spessore di 10-0

glatt
smooth
liso
lisse
liscia

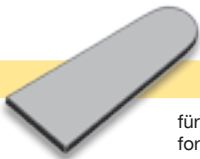

für feine Nadeln und Nahtmaterial in der Stärke 7-0 bis 10-0
 for delicate needles and sutures from sizes 7-0 to 10-0
 para agujas finas y material de sutura para espesores 7-0 y 10-0
 pour aiguilles fines et matériel à suture d'une épaisseur de 7-0 à 10-0
 per aghi fini e materiale per sutura fino ad uno spessore di 7-0 fino a 10-0



**Nadelhalter
Needle Holders
Porta-agujas
Porte-aiguilles
Portaghi**



Mayo-Hegar "HM"

N	16 cm – 6¼" 10.18.85	18 cm – 7⅛" 10.18.88	20 cm – 8" 10.18.90	23 cm – 9" 10.18.93



micro-slim "HM"

F	16 cm – 6¼" 10.24.85	18 cm – 7⅛" 10.24.88	20 cm – 8" 10.24.90	22 cm – 8¾" 10.24.93

"HM"
Hartmetall
Tungsten carbide
Carburo de tungsteno
Carbure de tungstène
Carburo di tungsteno

N
4-0
normal
regular
normal
normale
normale

F
5-0 and 6-0
fein
fine
fino
fine
fine



Mikro-Nadelhalter
Micro Needle Holders
Micro porta-agujas
Micro porte-aiguilles
Micro portaghi

21
8
20
19
18
7
17
6
16
5
15
4
14
3
13
2
12
1
11
10
9
3
8
7
6
5
4
3
2
1
cm | inch

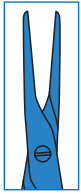

15 cm - 6"	18 cm - 7 1/8"	21 cm - 8 1/4"
12.16.75	12.18.85	12.21.95



15 cm - 6"	18 cm - 7 1/8"	21 cm - 8 1/4"
12.16.77	12.18.87	12.21.97



15 cm - 6"	18 cm - 7 1/8"	21 cm - 8 1/4"
12.16.76	12.18.86	12.21.96



15 cm - 6"	18 cm - 7 1/8"	21 cm - 8 1/4"
12.16.78	12.18.88	12.21.98



Rundgriff
 Round handle
 Mango redondo
 Manche rond
 Manico rotondo



mit Sperre
 with catch
 con cremallera
 avec crémaillère
 con cremagliera

Atraumatische Bulldog-Klemmen
Atraumatic Bulldog Clamps
Clamps Bulldog atraumáticas
Clamps Bulldog atraumatiques
Pinze Bulldog atraumatiche

- ▶ Delikate Modelle mit geringem Gewicht und differenzierter Schließkraft für Vene und Arterie
- ▶ Delicate types with light weight and different closing pressure for veins and arteries
- ▶ Modelos delicados con peso mínimo y fuerza de cierre diferenciada para venas y arterias
- ▶ Modèles délicats avec poids réduit et forces différentes de fermeture pour veines et pour artères
- ▶ Modelli delicati con peso minimo e forza di chiusura differenziata per vene ed arterie

1:1

3 cm – 1 1/8"	3,5 cm – 1 3/8"	4 cm – 1 1/2"	5 cm – 2"	
15.04.30	15.04.35	15.04.40	15.04.50	
3 cm – 1 1/8"	3,5 cm – 1 3/8"	4 cm – 1 1/2"	5 cm – 2"	
15.04.31	15.04.36	15.04.41	15.04.51	

1:1

3 cm – 1 1/8"	3,5 cm – 1 3/8"	4 cm – 1 1/2"	5 cm – 2"	
15.05.30	15.05.35	15.05.40	15.05.50	
3 cm – 1 1/8"	3,5 cm – 1 3/8"	4 cm – 1 1/2"	5 cm – 2"	
15.05.31	15.05.36	15.05.41	15.05.51	

1:1

3 cm – 1 1/8"	3,5 cm – 1 3/8"	4 cm – 1 1/2"	5 cm – 2"	
15.07.30	15.07.35	15.07.40	15.07.50	
3 cm – 1 1/8"	3,5 cm – 1 3/8"	4 cm – 1 1/2"	5 cm – 2"	
15.07.31	15.07.36	15.07.41	15.07.51	

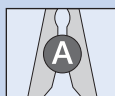

starke Schließkraft, für Arterien
 strong closing pressure, for arteries
 fuerza de cierre alta, para arterias
 force de fermeture forte, pour artères
 forza di chiusura forte, per arterie

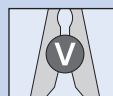

schwache Schließkraft, für Venen
 soft closing pressure, for veins
 fuerza de cierre baja, para venas
 force de fermeture faible, pour veines
 forza di chiusura debole, per vene



Arterienklemmen
Hemostatic Forceps
Pinzas hemostáticas
Pinces hémostatiques
Pinze emostatiche



Halsted-Mosquito



12,5 cm - 5"
15.44.32



12,5 cm - 5"
15.45.32



12,5 cm - 5"
15.46.32

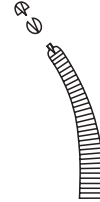

12,5 cm - 5"
15.47.32



Kelly



14 cm - 5½"
15.70.34



14 cm - 5½"
15.71.34

Arterien- und Gefäßklemmen
Hemostatic and Cardiovascular Forceps
Pinzas hemostáticas y vasculares
Pinces hémostatiques et vasculaires
Pinze emostatiche e vascolari

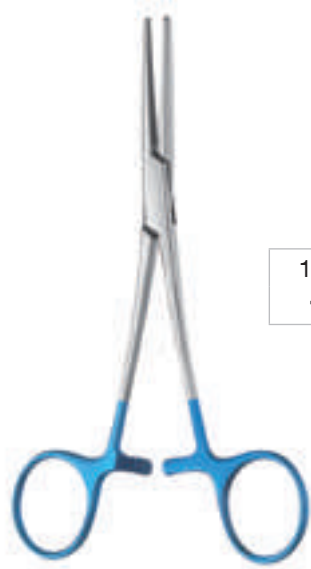

Crile

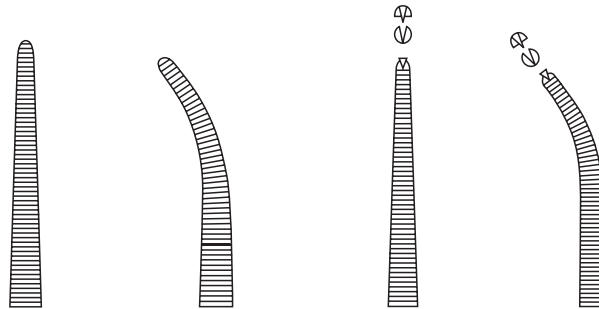

14 cm - 5½"	14 cm - 5½"	14 cm - 5½"	14 cm - 5½"
15.72.34	15.73.34	15.72.74	15.73.74

Gefäßklemmen
 Cardiovascular clamps
 Pinzas vasculares
 Pinces vasculaires
 Pinze vascolari



Cooley "AT"

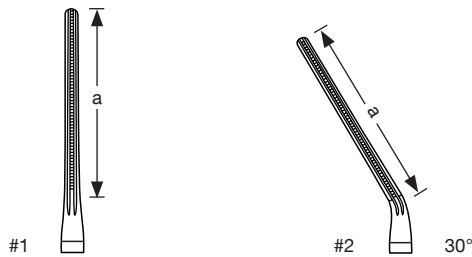

#1	#2 30°
a = 25 mm 11 cm - 4¾"	a = 25 mm 11 cm - 4¾"
55.32.21	55.32.22

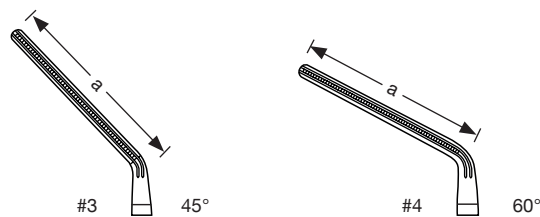

#3 45°	#4 60°
a = 25 mm 11 cm - 4¾"	a = 25 mm 10,5 cm - 4¼"
55.32.23	55.32.24



Gefäßklemmen
Cardiovascular Clamps
Pinzas vasculares
Pinces vasculaires
Pinze vascolari



Neonatal

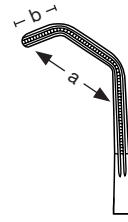
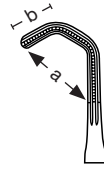

a = 10 mm b = 6 mm 10 cm - 4" 55.39.38	a = 10 mm b = 6 mm 10 cm - 4" 55.39.40	a = 12 mm b = 6 mm 11 cm - 4 3/8" 55.39.45
--	--	--

Anastomosenklemme
Anastomosis clamp
Pinza para anastomosis
Pince à anastomoses
Pinza per anastomosi



DeBaKey-Glover "AT"

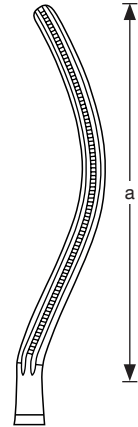

a = 50 mm 22 cm - 8 3/4" 55.44.41
--

"AT"

 Atraumatische Riefung
 Atraumatic serration
 Estrías atraumáticas
 Striure atraumatique
 Zigrinatura atraumatica

Gefäßklemmen
Cardiovascular Clamps
Pinzas vasculares
Pinces vasculaires
Pinze vascolari

Peripheralgefäßklemme
Peripheral vascular clamp
Pinza para vasos periféricos
Pince pour vaisseaux périphériques
Pinza emostatica per vasi periferici

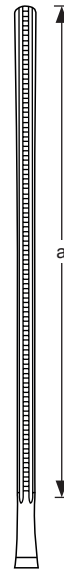

Leland-Jones "AT"



a = 65 mm
23 cm - 9"
55.50.30

"AT"



Atraumatische Riefung
Atraumatic serration
Estrías atraumáticas
Striure atraumatique
Zigrinatura atraumatica



Gefäßklemmen
Cardiovascular Clamps
Pinzas vasculares
Pinces vasculaires
Pinze vascolari



DeBakey "AT"

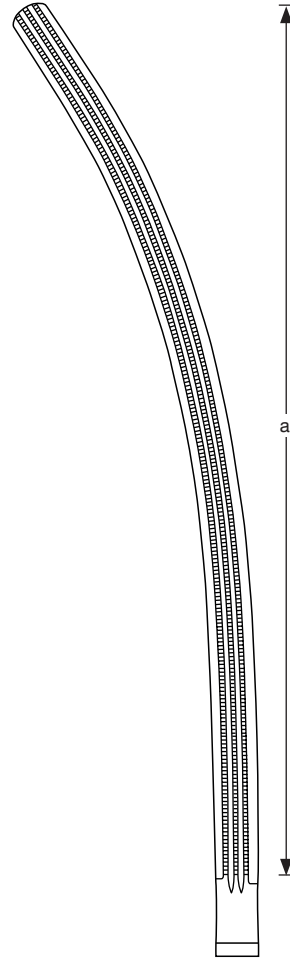

a = 115 mm
 32 cm - 12½"
55.60.23

"AT"

 Atraumatische Riefung
 Atraumatic serration
 Estrías atraumáticas
 Striure atraumatique
 Zigrinatura atraumatica

Gefäßklemmen
Cardiovascular Clamps
Pinzas vasculares
Pinces vasculaires
Pinze vascolari

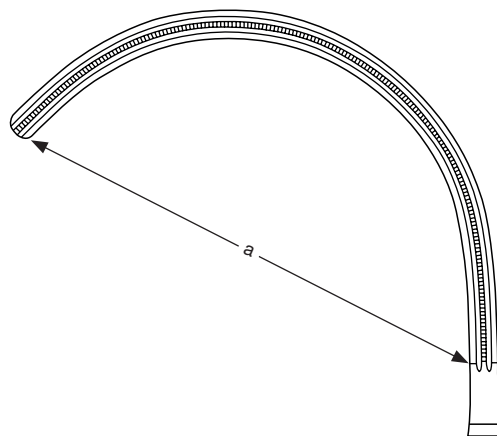
Ligaturklemme
 Ligature clamp
 Pinza para ligadura
 Pince à ligature
 Pinza per legatura



a = 65 mm
 25 cm - 10"
55.64.56

Semb-DeBakey "AT"



"AT"
 Atraumatische Riefung
 Atraumatic serration
 Estriás atraumáticas
 Striure atraumatique
 Zigrinatura atraumatica



Gefäßklemmen
Cardiovascular Clamps
Pinzas vasculares
Pinces vasculaires
Pinze vascolari

Ligaturklemme
 Ligature clamp
 Pinza para ligadura
 Pince à ligature
 Pinza per legatura



DeBakey "AT"

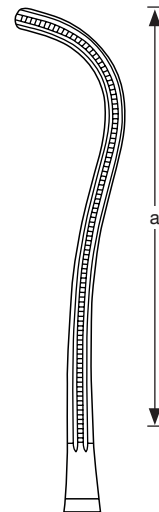

a = 55 mm
 22 cm - 8¾"
55.64.78



"AT"



Atraumatische Riefung
 Atraumatic serration
 Estrías atraumáticas
 Striure atraumatiques
 Zigrinatura atraumatica

Gefäßklemmen
Cardiovascular Clamps
Pinzas vasculares
Pinces vasculaires
Pinze vascolari

Aorta-Klemme
 Aorta clamp
 Pinza para aorta
 Pince pour l'aorte
 Pinza per aorta

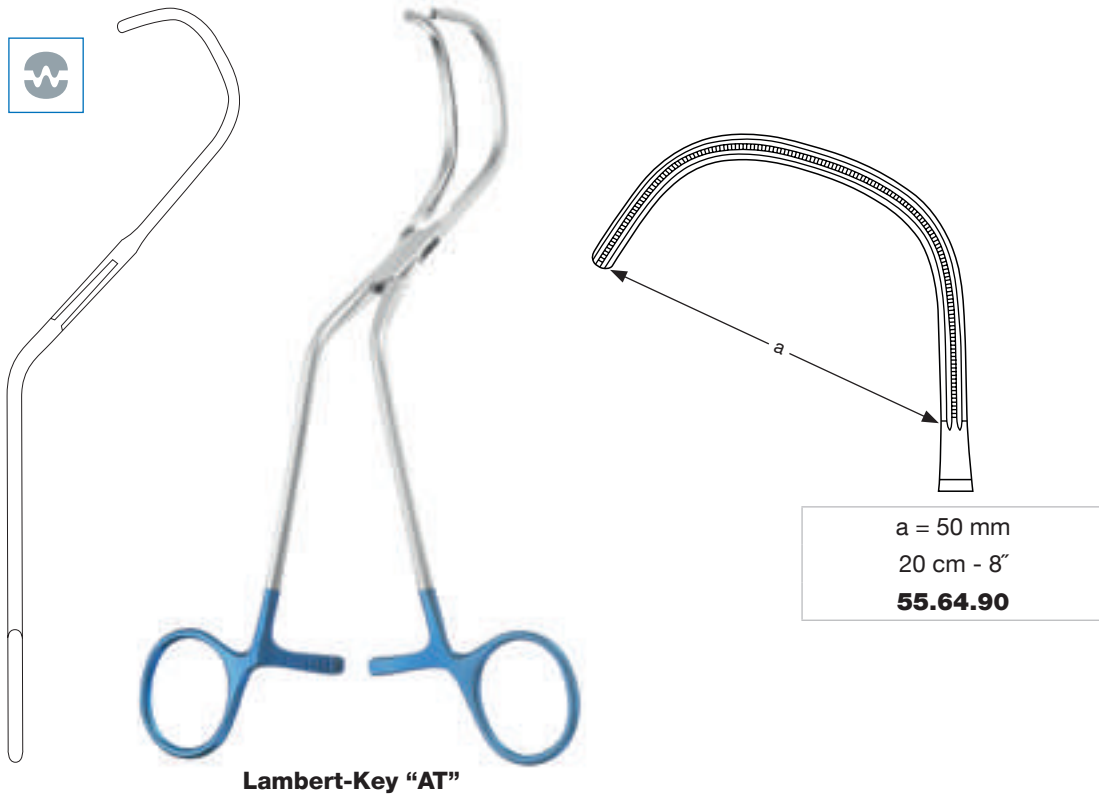



Gefäßklemmen
Cardiovascular Clamps
Pinzas vasculares
Pinces vasculaires
Pinze vascolari

Vena-Cava-Klemmen
 Vena cava clamps
 Pinzas de vena cava
 Pinces pour vena cava
 Pinze per vena cava



Satinsky-DeBakey "AT"

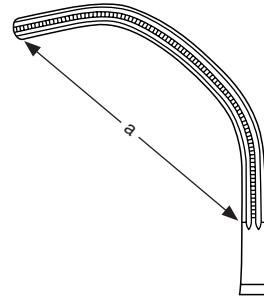

a = 40 mm
 20 cm - 8"
55.74.19

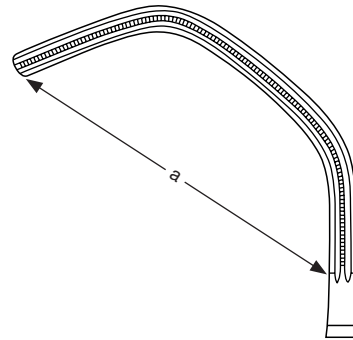

a = 50 mm
 25 cm - 10"
55.74.20



||| CMF

||| SURGICAL

||| NEURO+SPINE



Medicon eG

Gänsäcker 15
D-78532 Tuttlingen

P. O. Box 44 55
D-78509 Tuttlingen

Tel.: +49 (0) 74 62 / 20 09-0
Fax: +49 (0) 74 62 / 20 09-50

E-Mail: sales@medicon.de
Internet: www.medicon.de

Germany

